

**DE Anleitung für Montage, Betrieb, Wartung und Demontage**

Sektionaltore für Industrie Baureihe 60, Bautiefe 42 / 67 mm

**EN Instructions for Fitting, Operating, Maintenance and Dismantling**

Series 60 Industrial Sectional Doors, depth 42 / 67 mm

**FR Notice de montage, d'utilisation, d'entretien et de démontage**

Porte sectionnelle industrielle série 60, épaisseur 42 / 67 mm

**ES Instrucciones para el montaje, funcionamiento, mantenimiento y desmontaje**

Puertas seccionales industriales Serie 60, profundidad 42 / 67 mm

**RU Руководство по монтажу, эксплуатации, техобслуживанию и демонтажу**

Секционные ворота для гаража строительной серии 60, строительная глубина 42 / 67 мм

+

NL	PL	SL	FI	TR	LV	EL
IT	HU	NO	DA	LT	HR	RO
PT	CS	SV	SK	ET	SR	BG

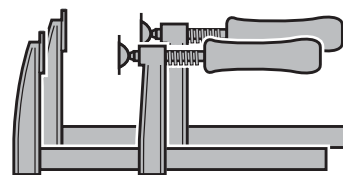
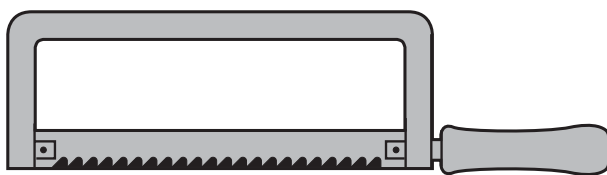
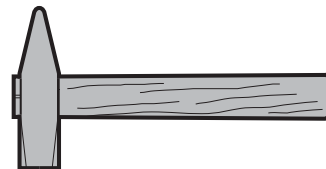
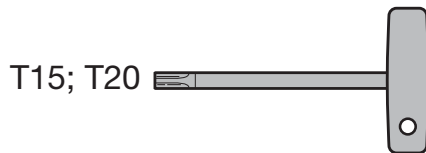
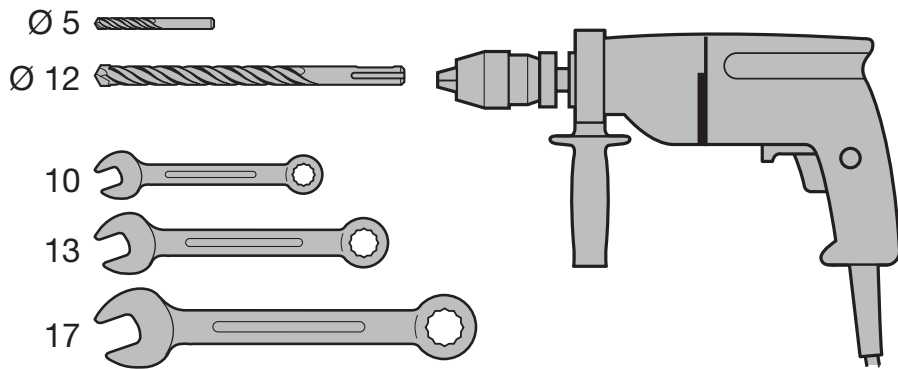
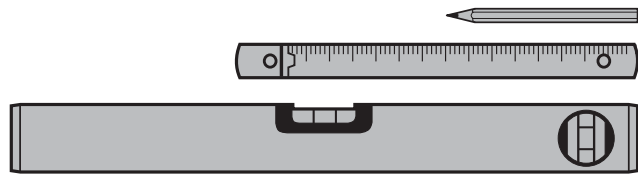
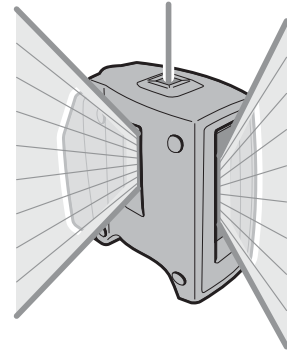
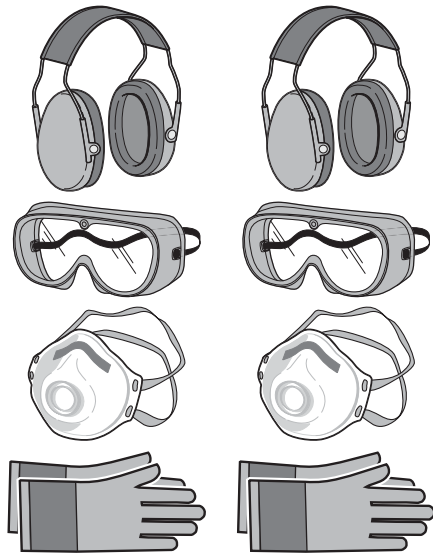
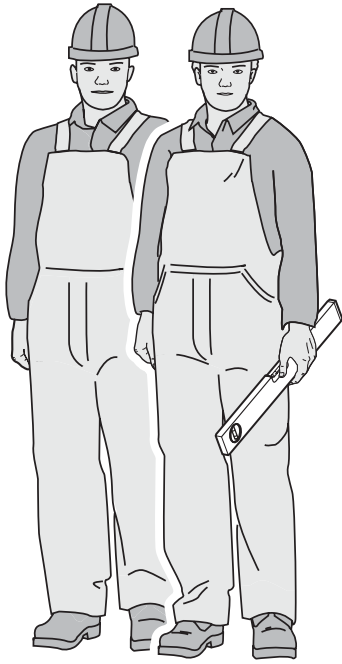

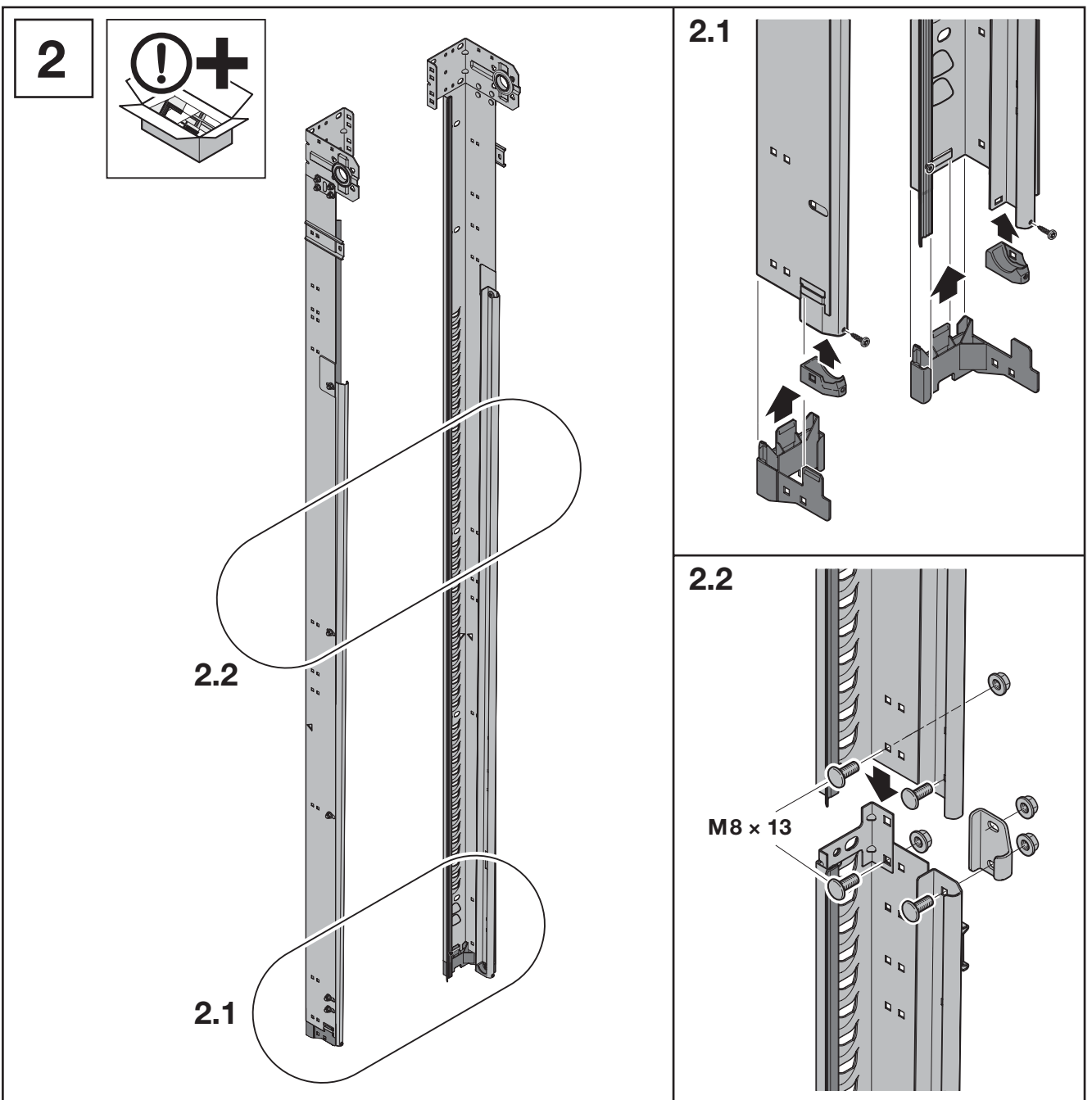
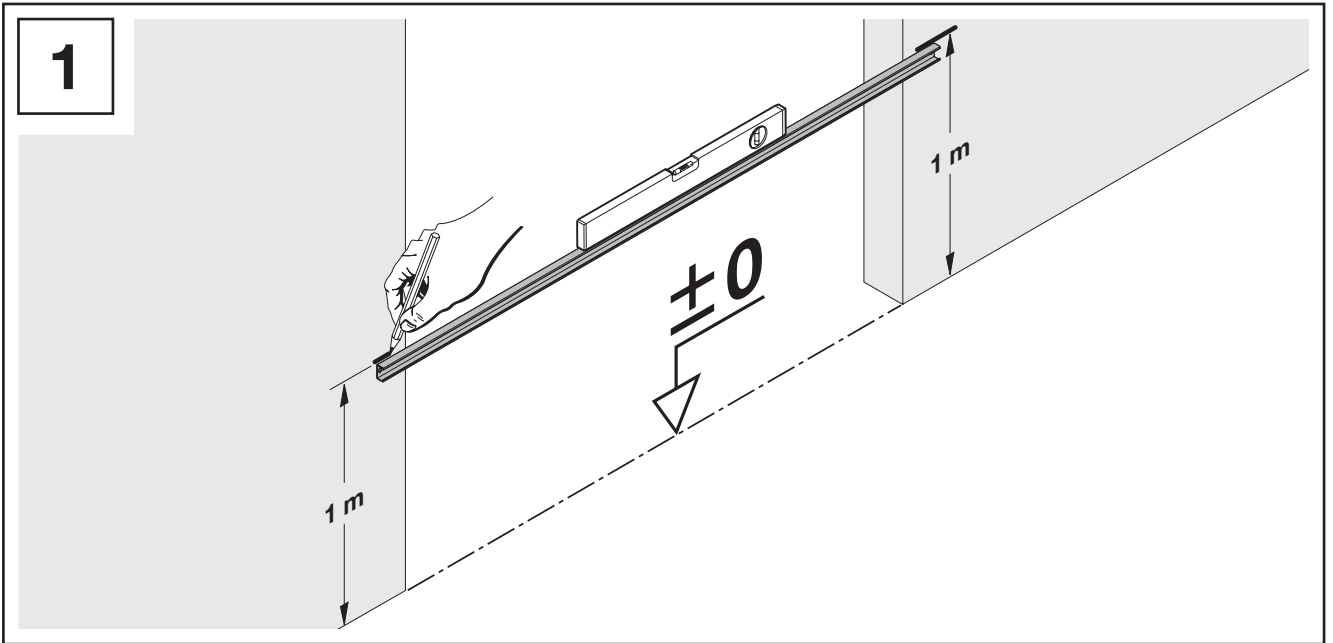

3

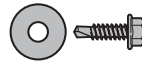
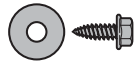
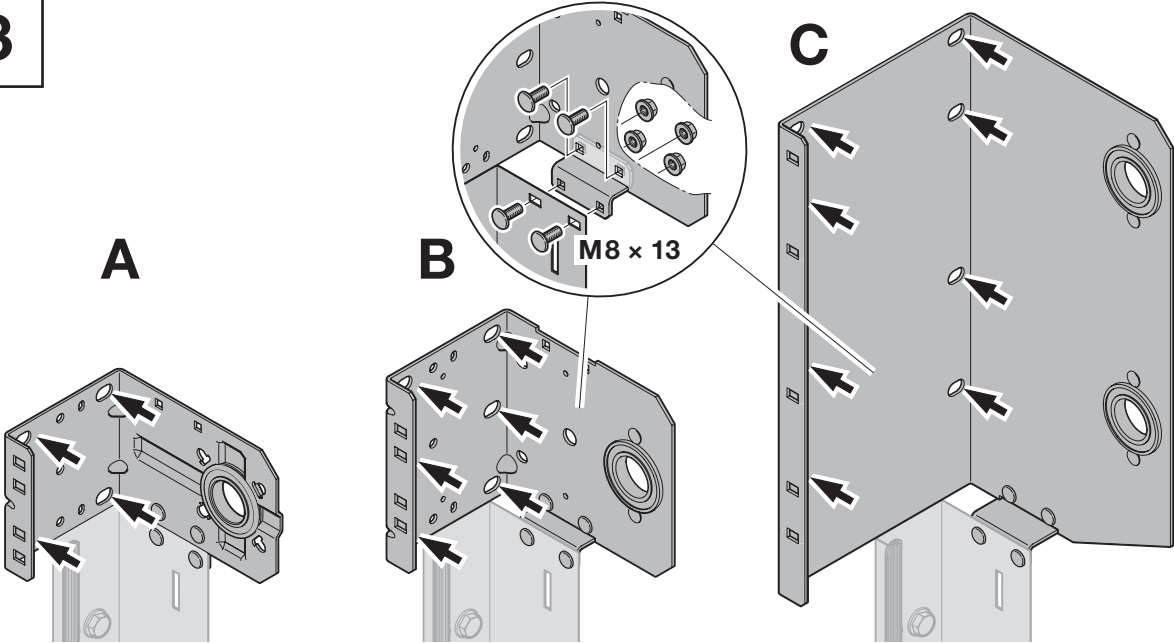

➔ 3.2

3.1

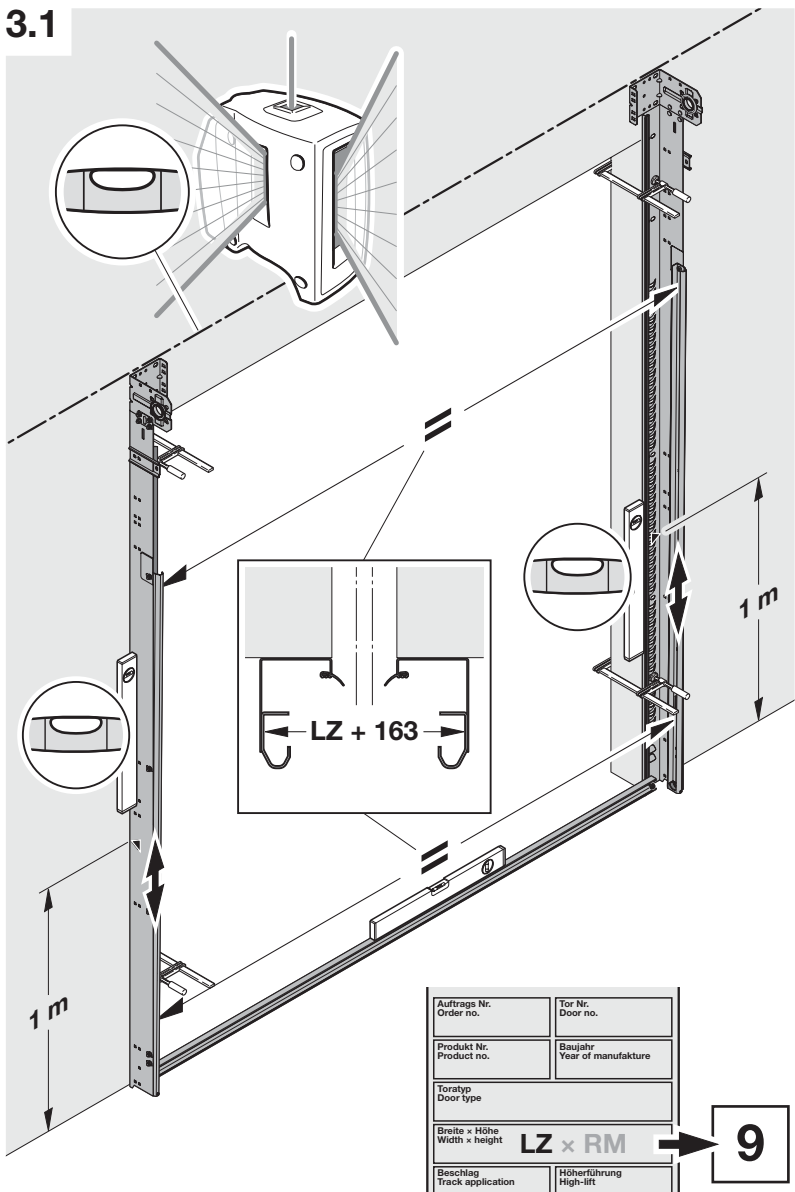

9

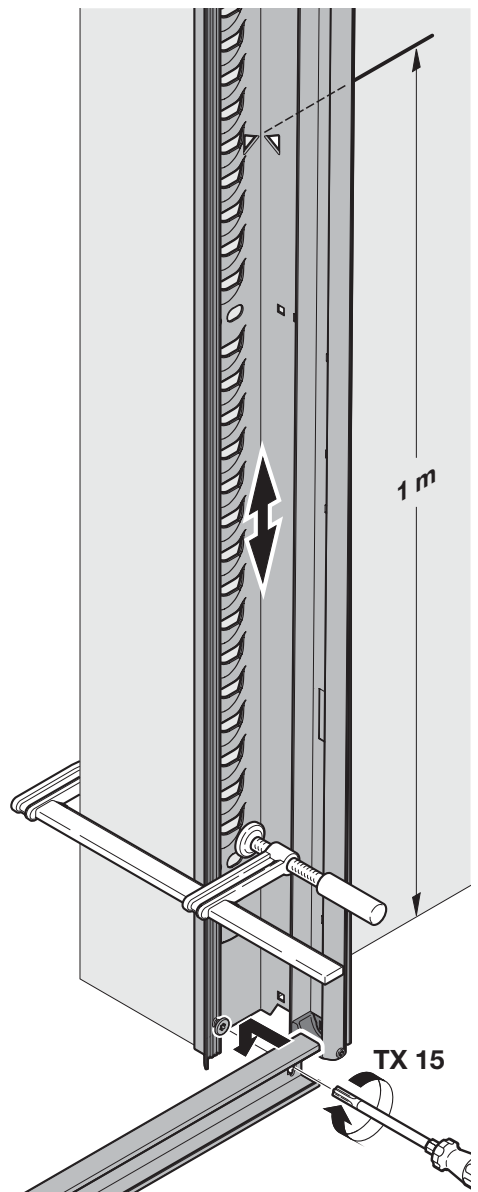

TX 15

3.2a

12 A10,5 10 x 70

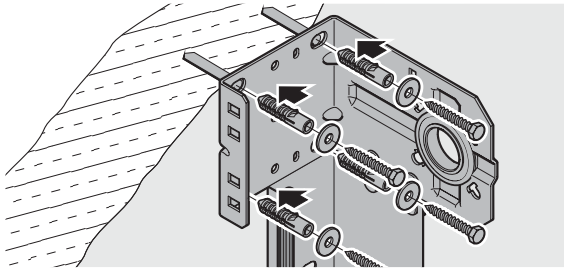

3.2b

B 8 x 22 ST 8 x 30

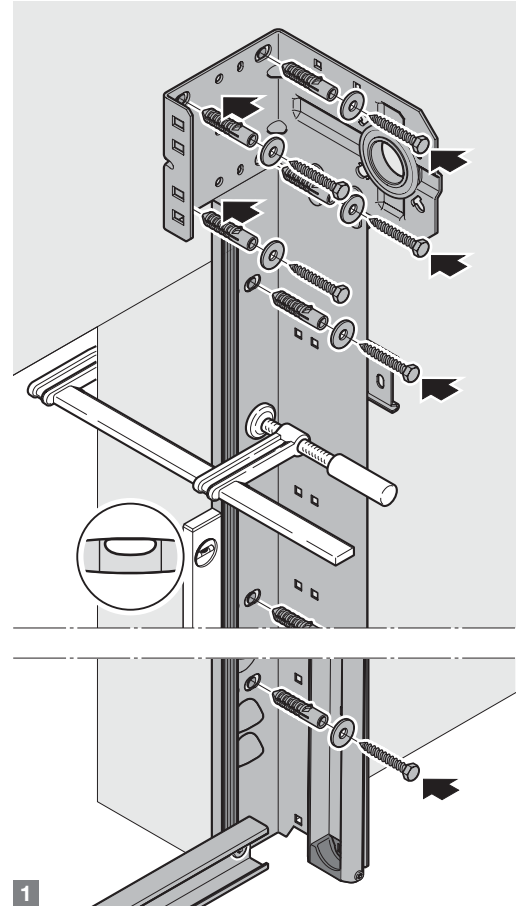
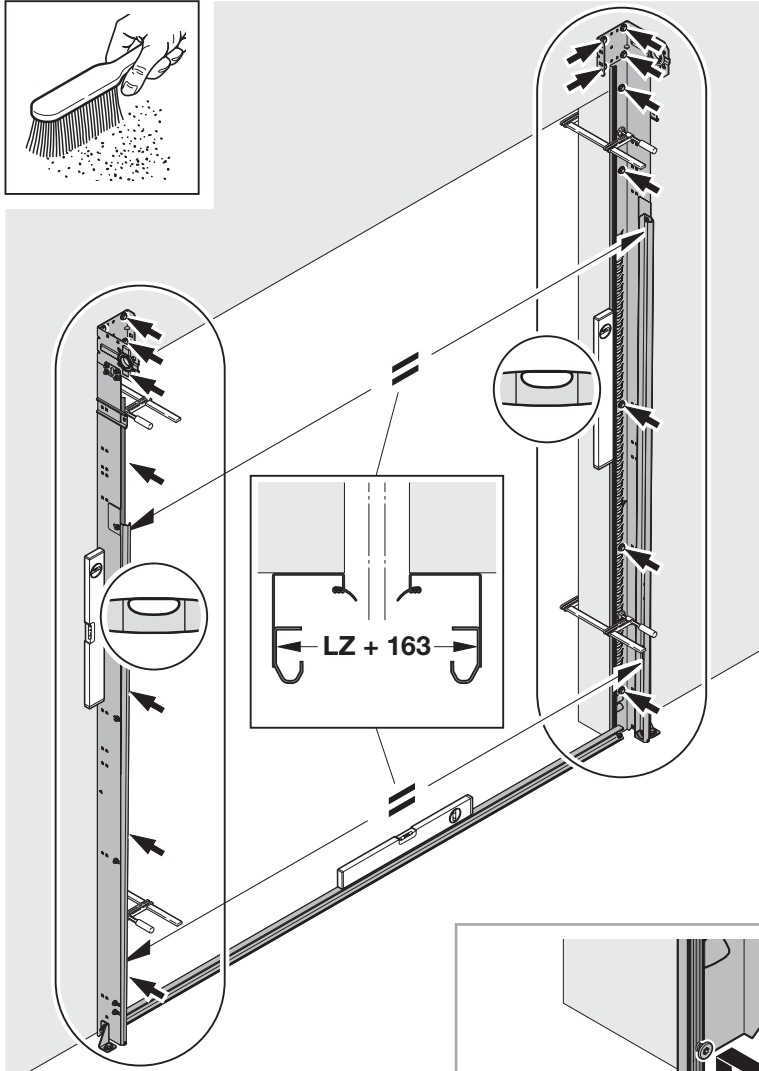
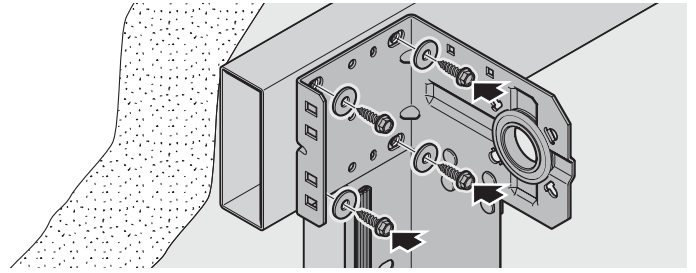

Auftrags Nr. Order no.	Tür Nr. Door no.
Produkt Nr. Product no.	Baujahr Year of manufacture
Türtyp Door type	
Breite x Höhe Width x height	
<b>LZ x RM</b>	
Beschlag Track application	Höherführung High-lift

9

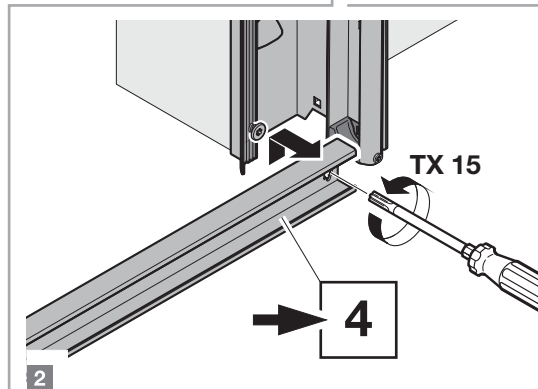

4

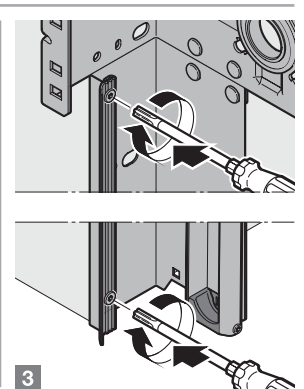

3

3.3a

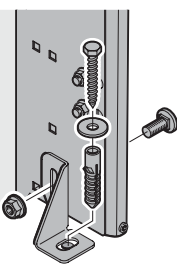

3.3b

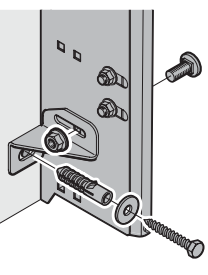

3098360

4

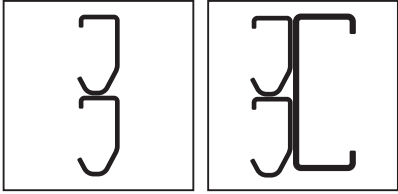

$a = b$

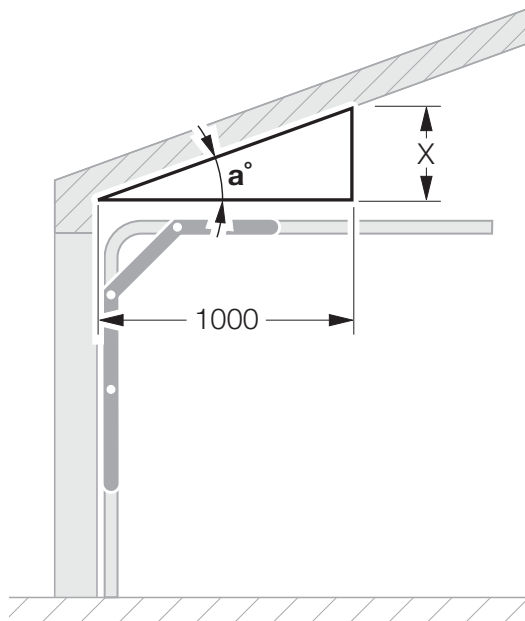
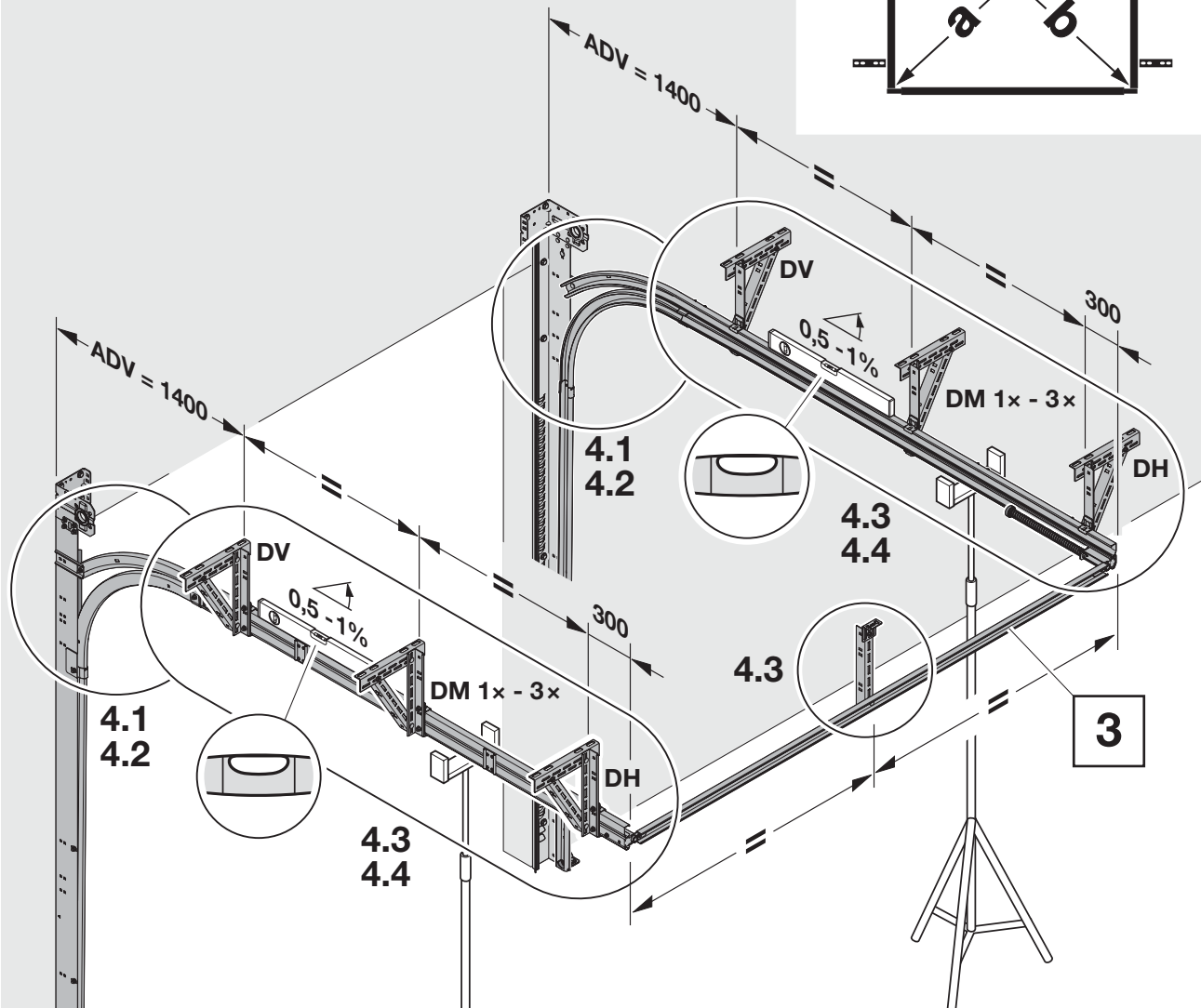
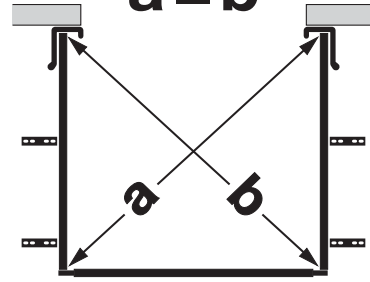

$a^\circ$	%	X (mm)	$a^\circ$	%	X (mm)
1	1,75	17,5	16	28,67	286,7
2	3,49	34,9	17	30,57	305,7
3	5,24	52,4	18	32,49	324,9
4	6,99	69,9	19	34,43	344,3
5	8,75	87,5	20	36,40	364,0
6	10,51	105,1	21	38,39	383,9
7	12,28	122,8	22	40,40	404,0
8	14,05	140,5	23	42,45	424,5
9	15,84	158,4	24	44,52	445,2
10	17,63	176,3	25	46,63	466,3
11	19,44	194,4	26	48,77	487,7
12	21,26	212,6	27	50,95	509,5
13	23,09	230,9	28	53,17	531,7
14	24,93	249,3	29	55,43	554,3
15	26,79	267,9	30	57,74	577,4

# 4.1

1

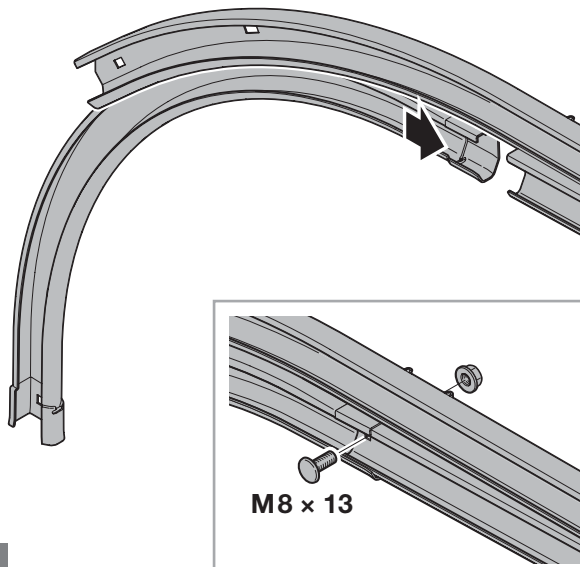

M8 x 13

2

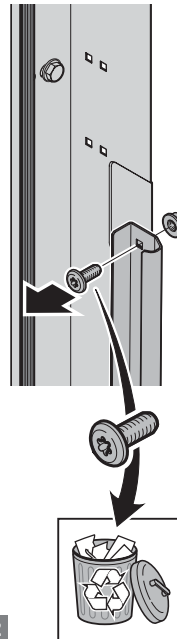

3

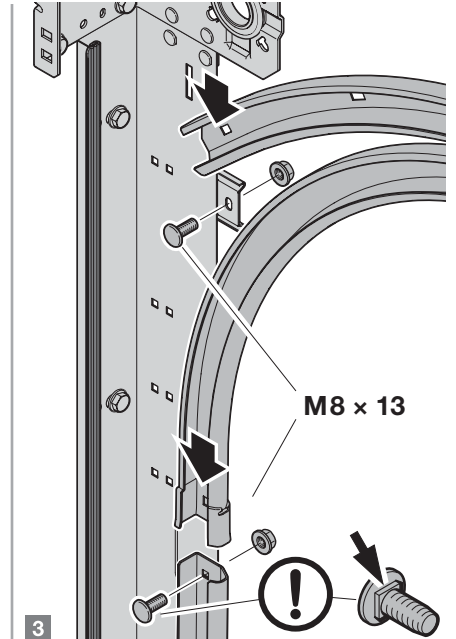

M8 x 13

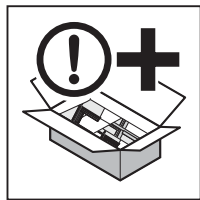

**A**

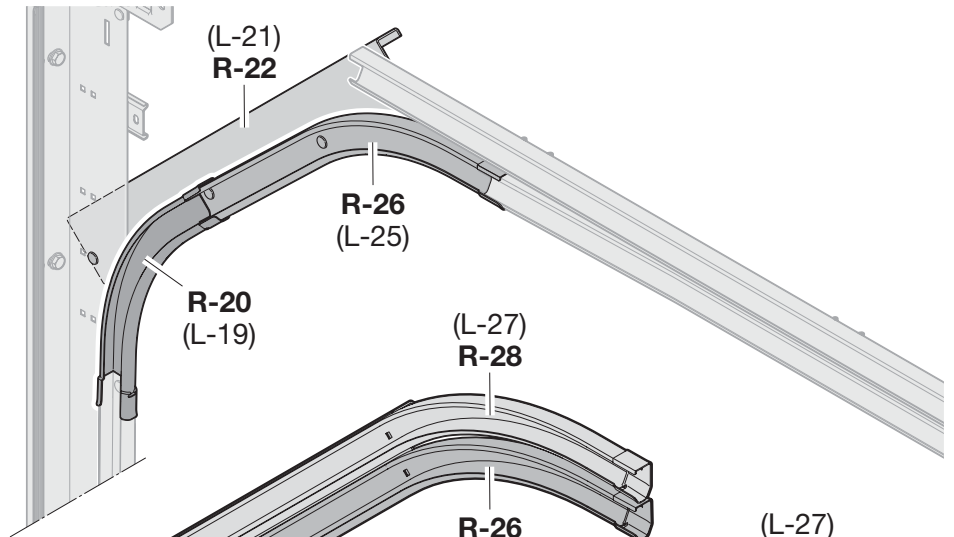

**B**

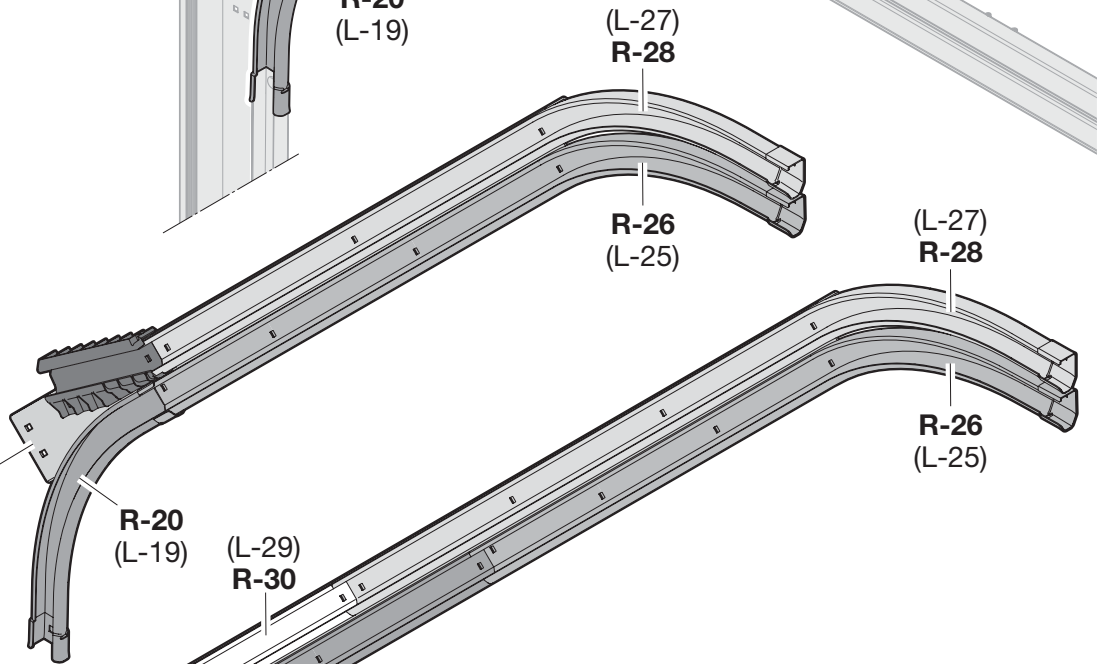

**C**

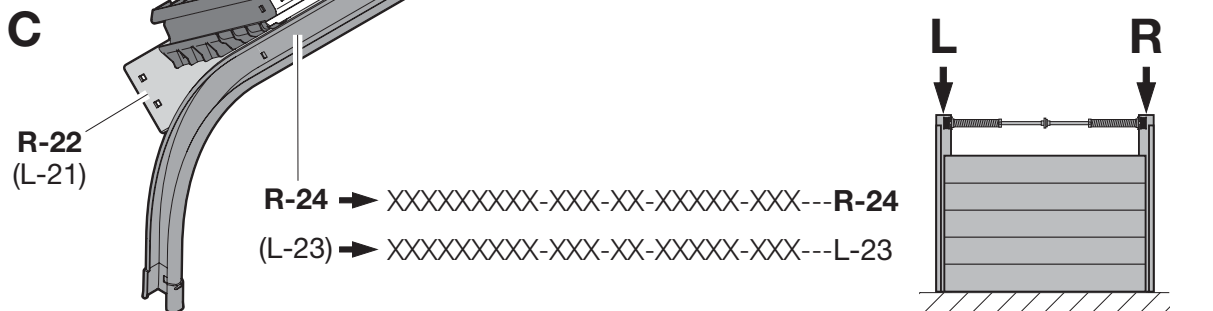

4.2a

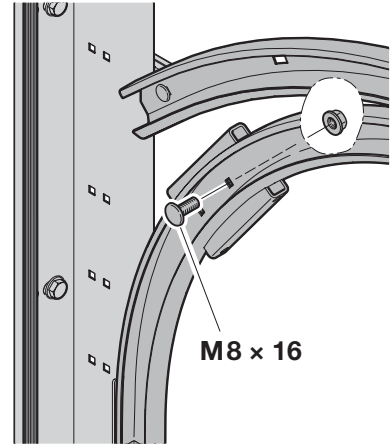
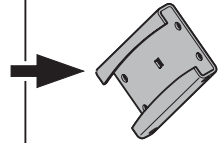
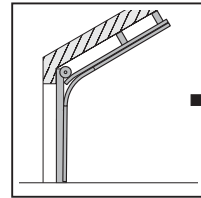
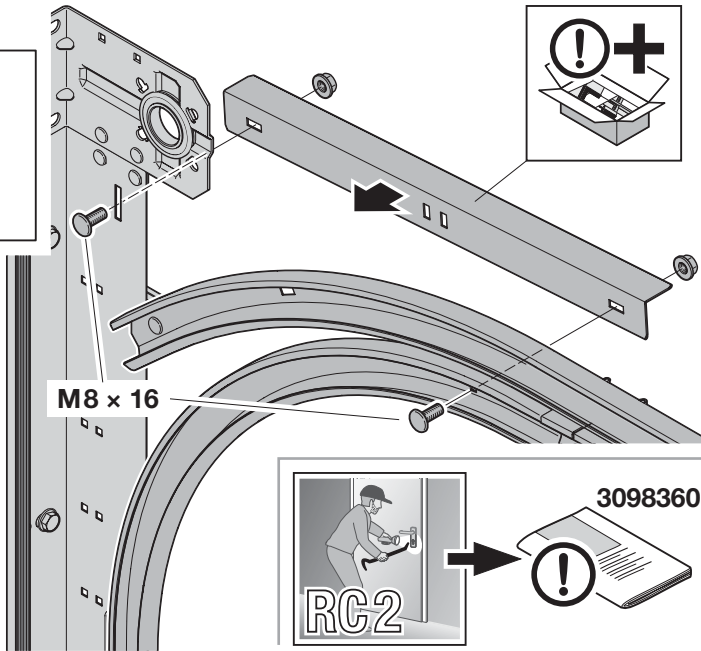
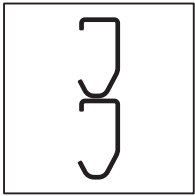

4.2b

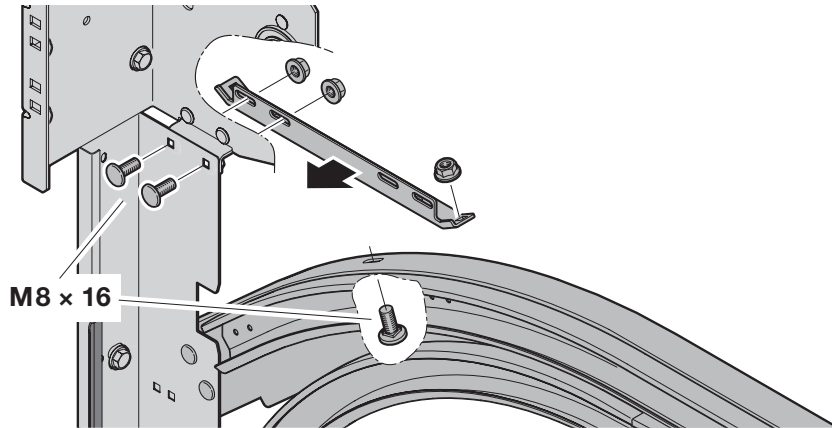
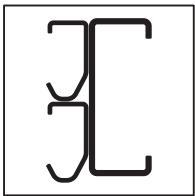

4.3a

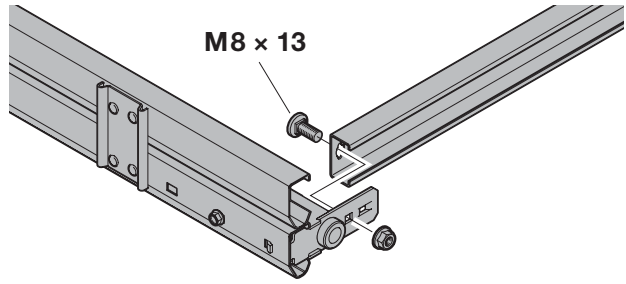
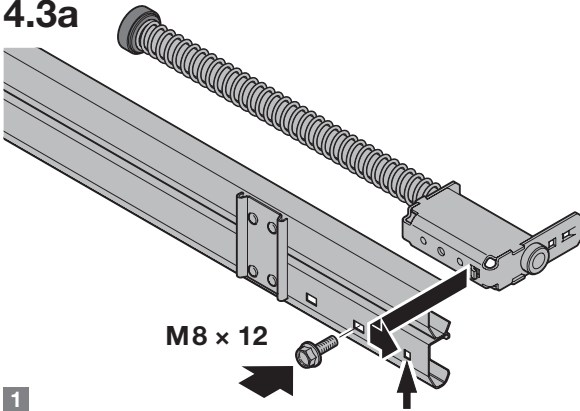

LZ > 5500

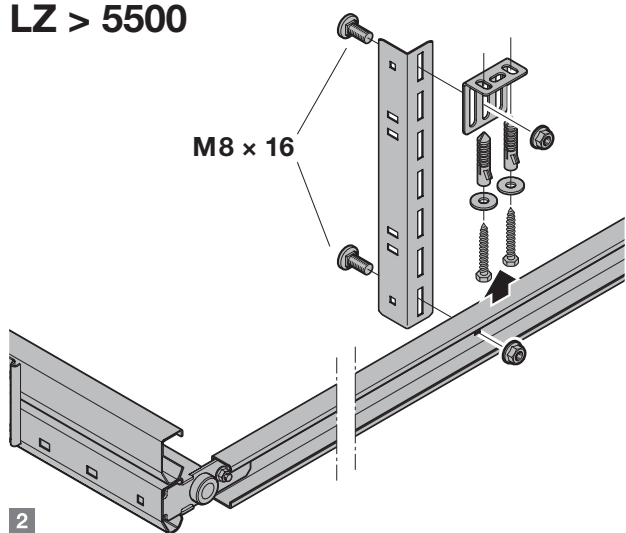

4.3b

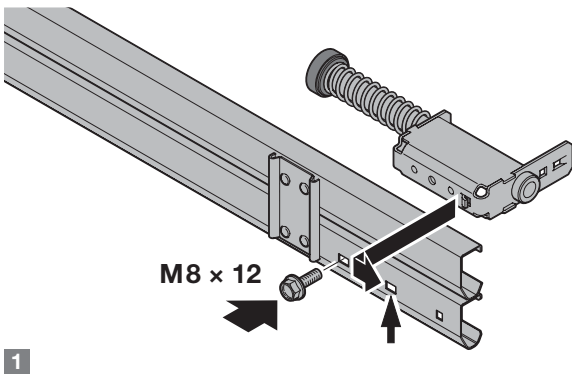



### 4.4a

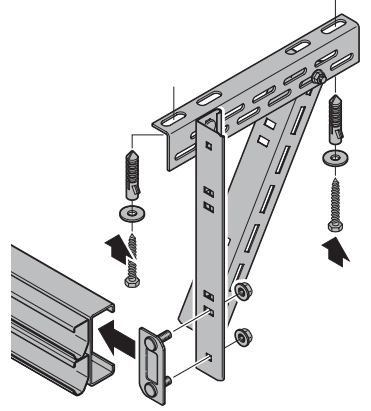
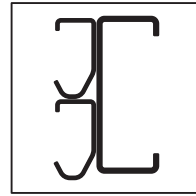
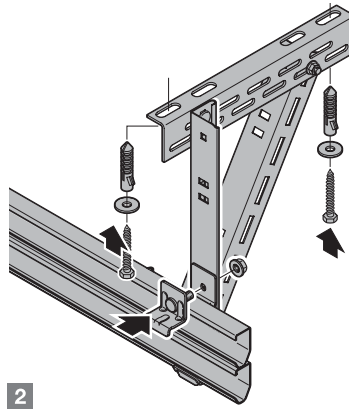
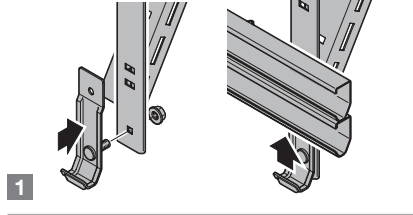
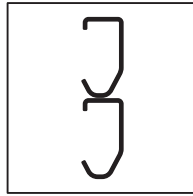
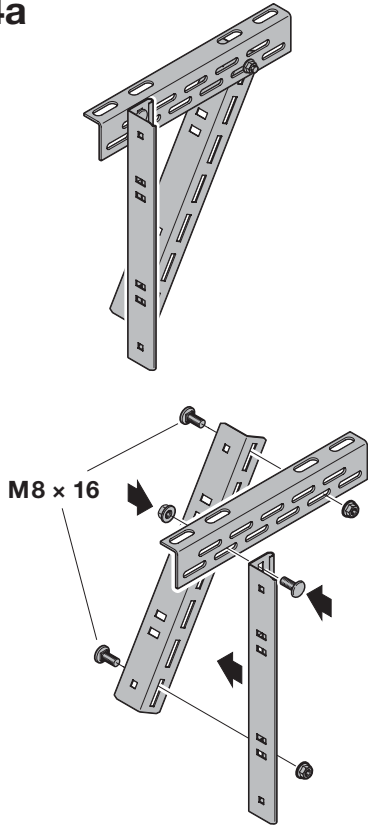

### 4.4b

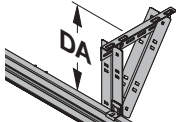
 kg	 DA
< 201	> 1768
201 - 300	> 1405
> 300	> 1041

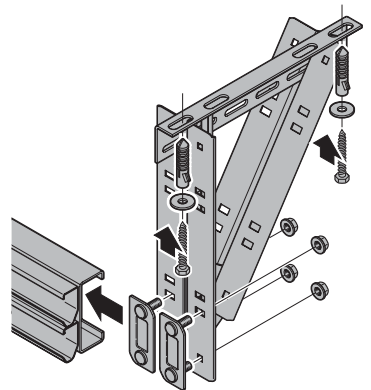
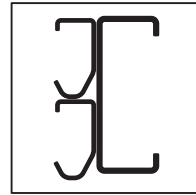
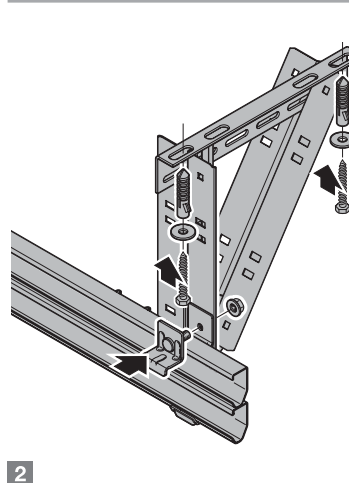
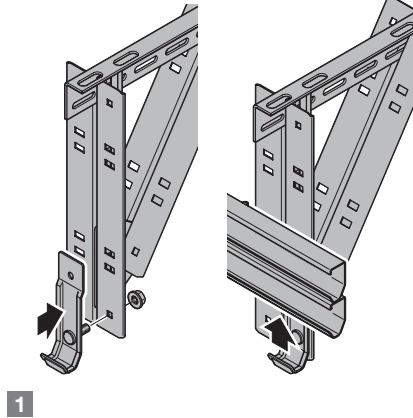
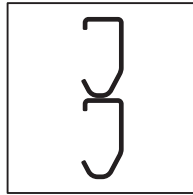
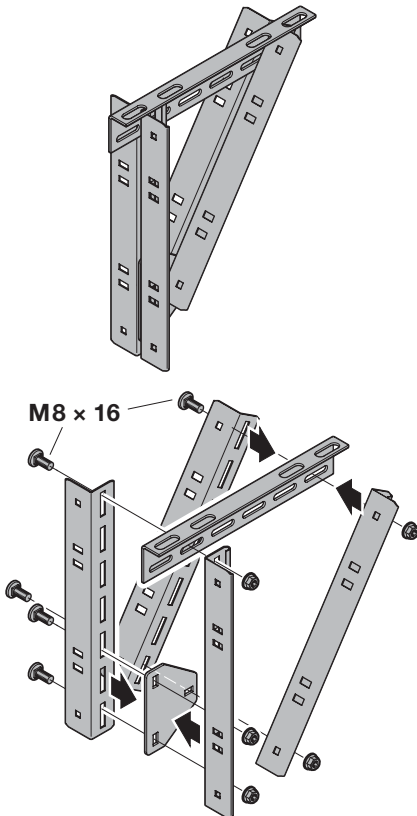

5a

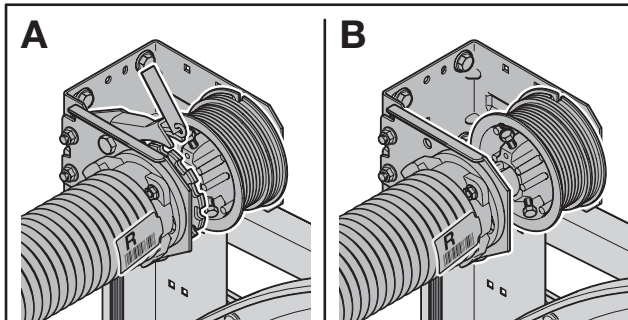
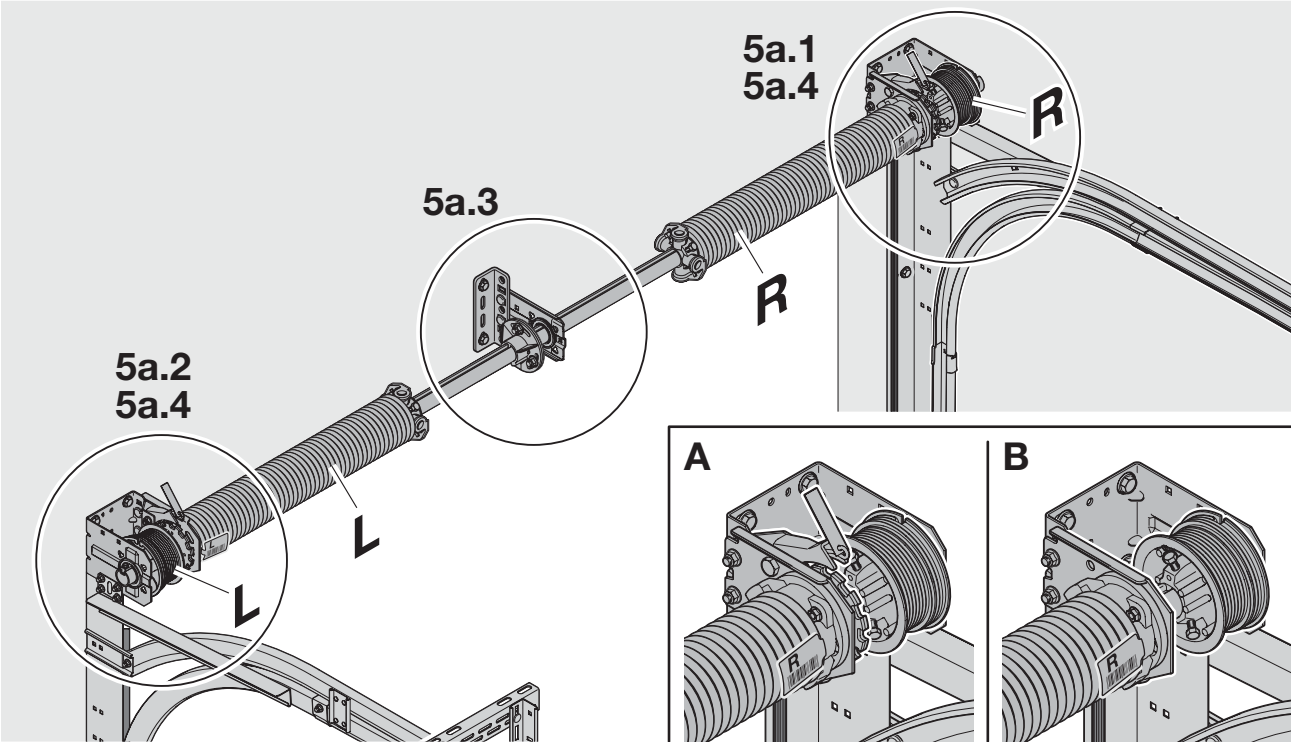
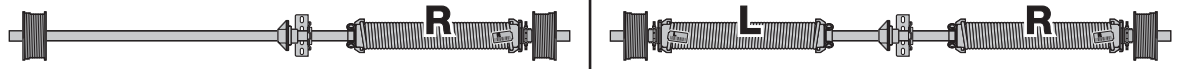

5a.1

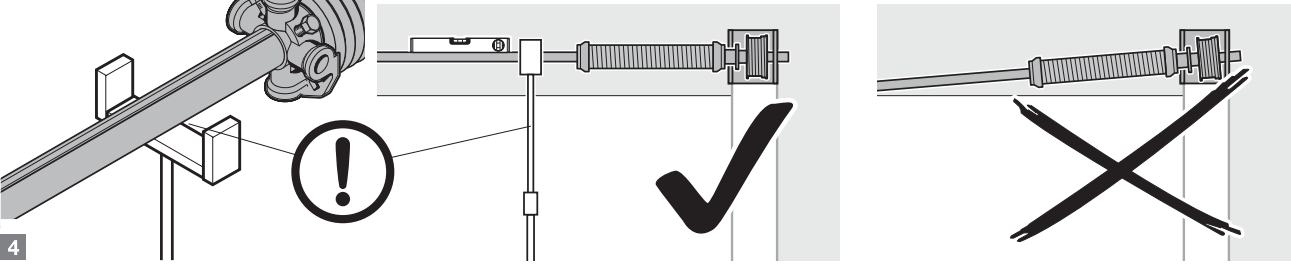
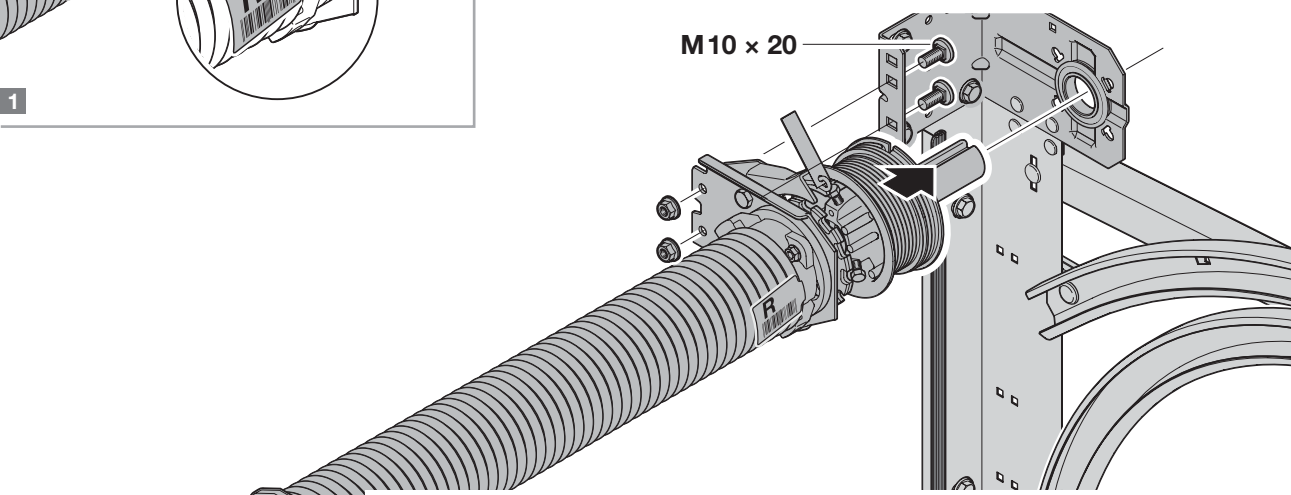
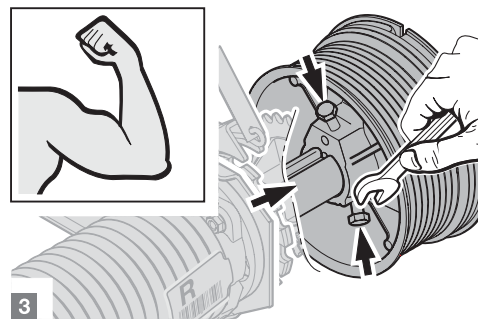
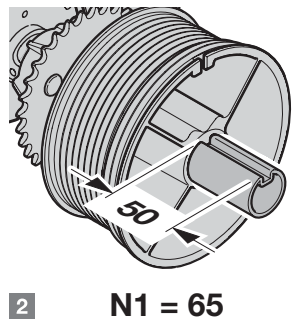
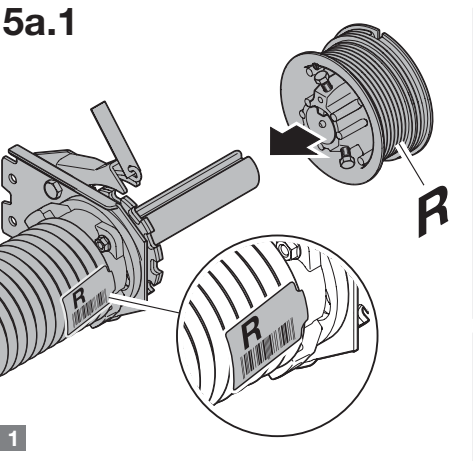

5a.2

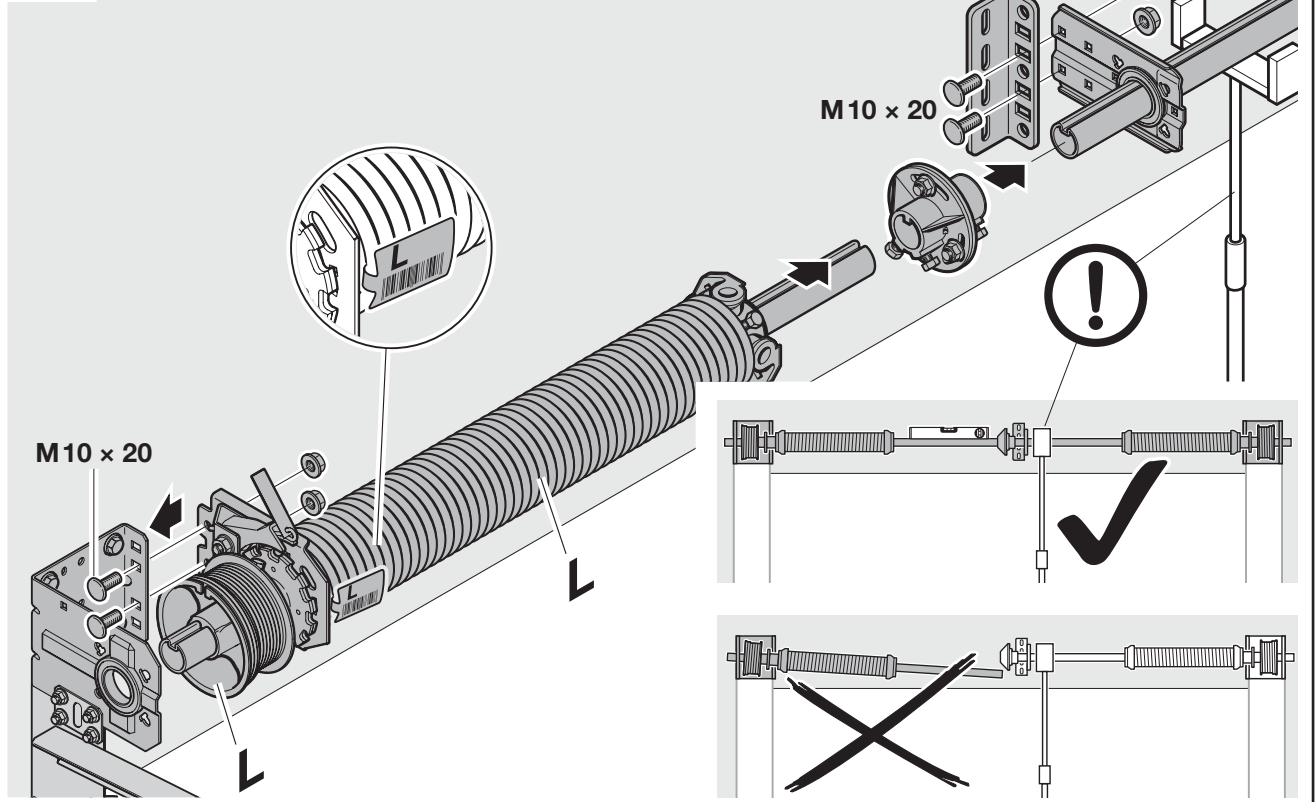

5a.3

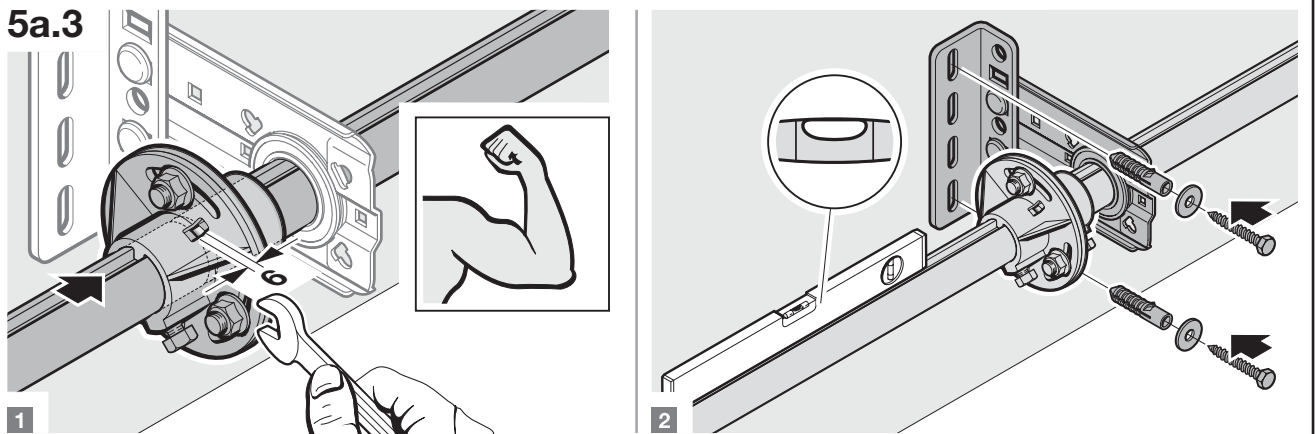

5a.4

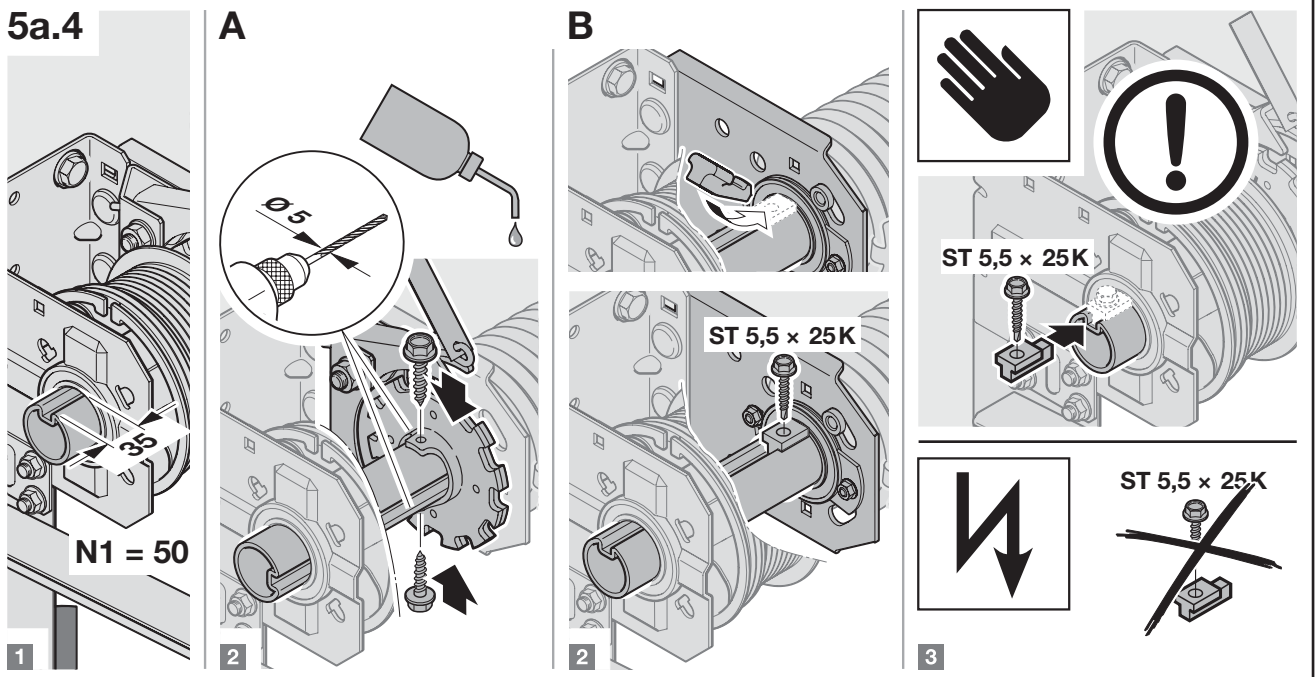

**5b**

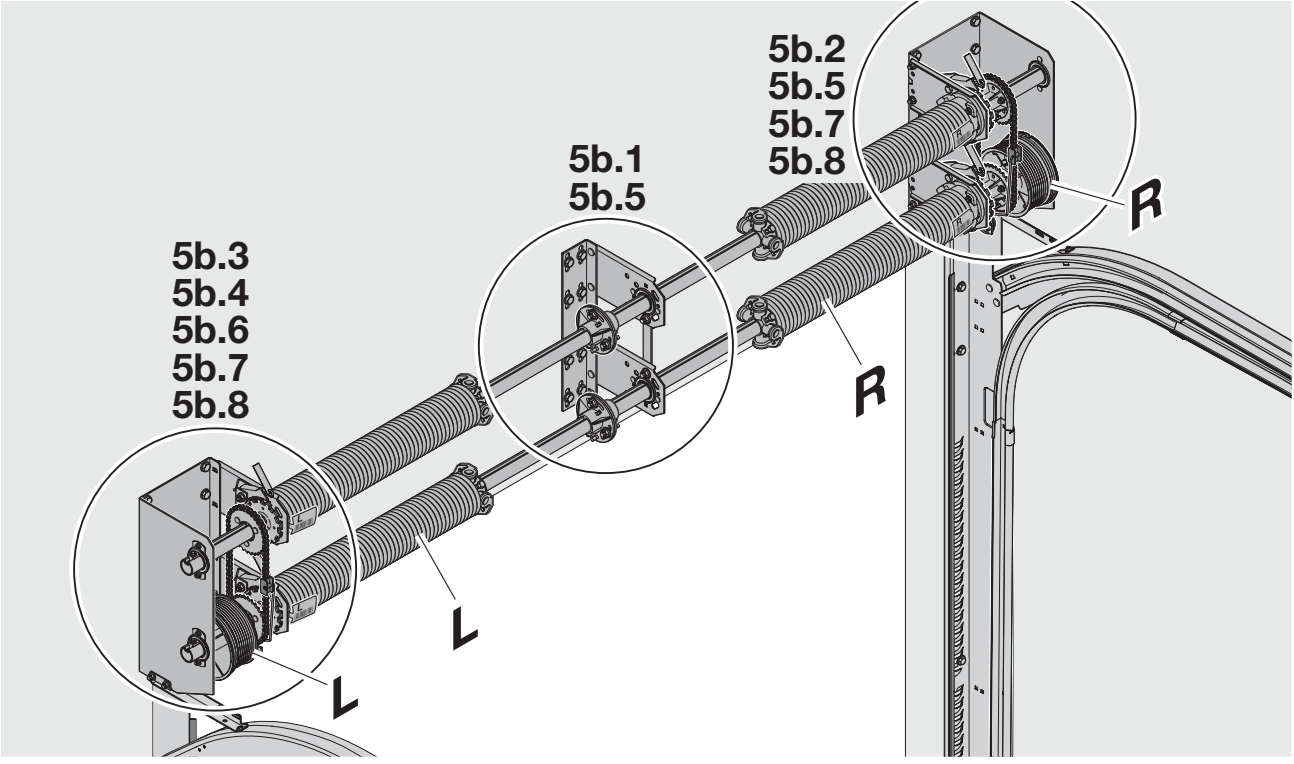
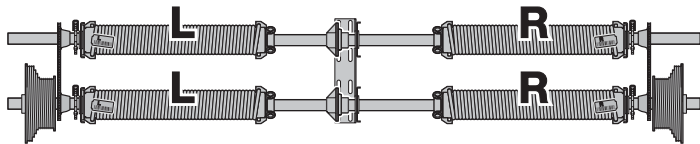

**5b.1**

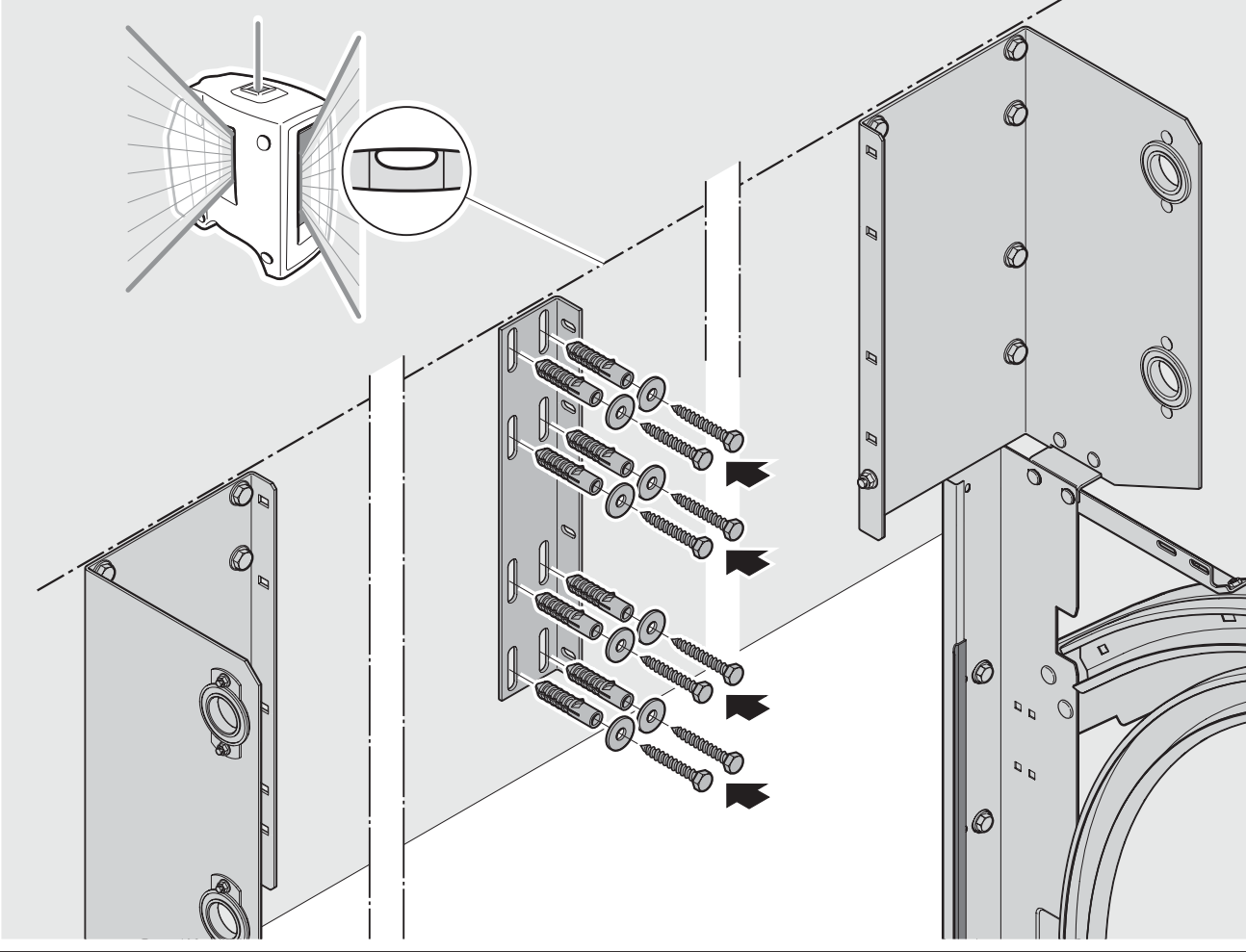

5b.2

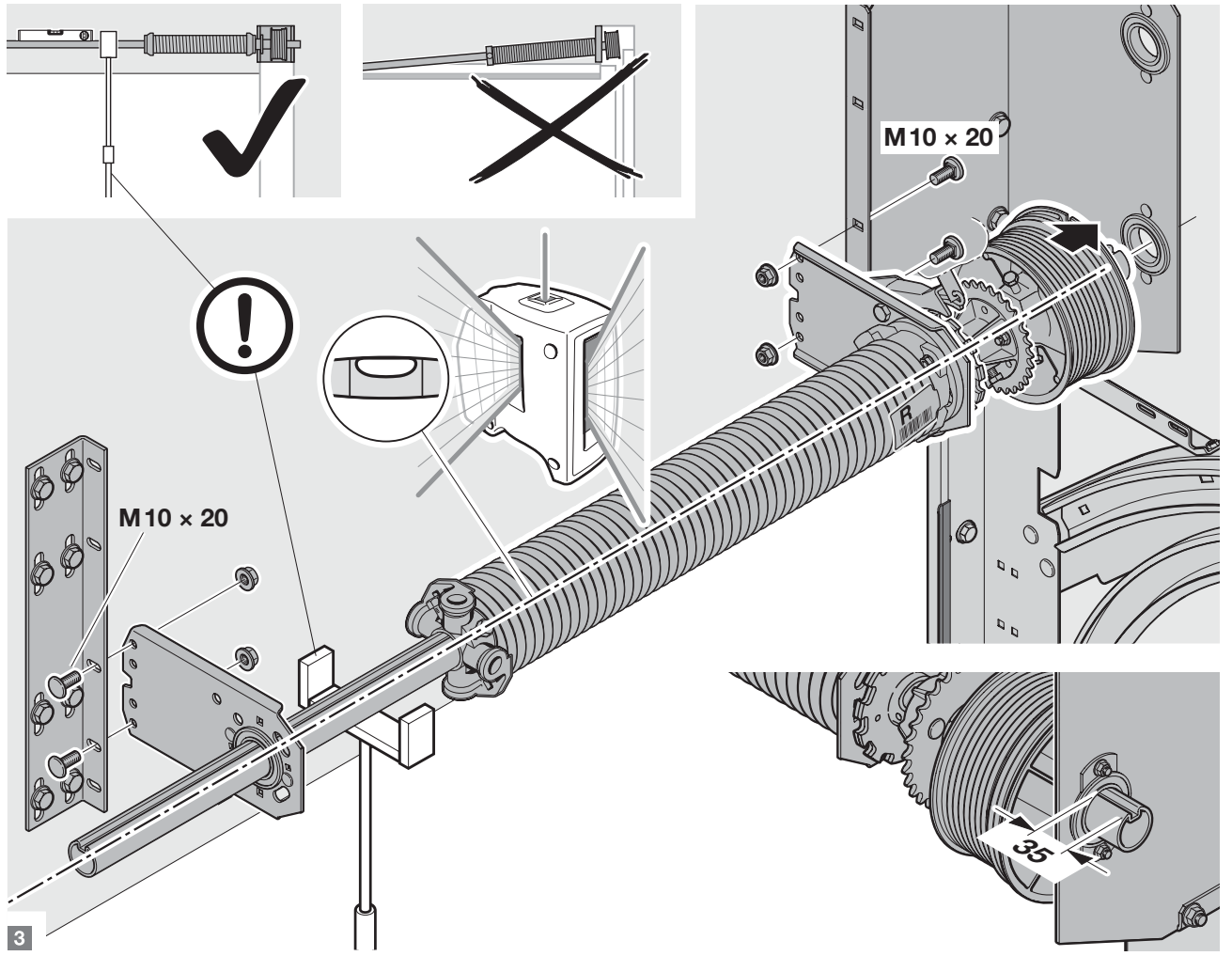
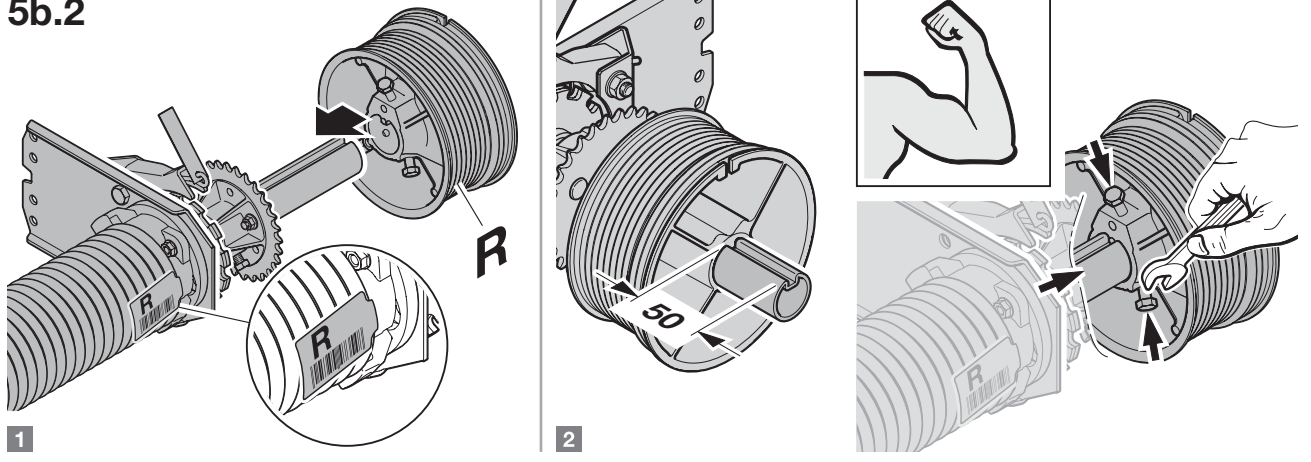

5b.3

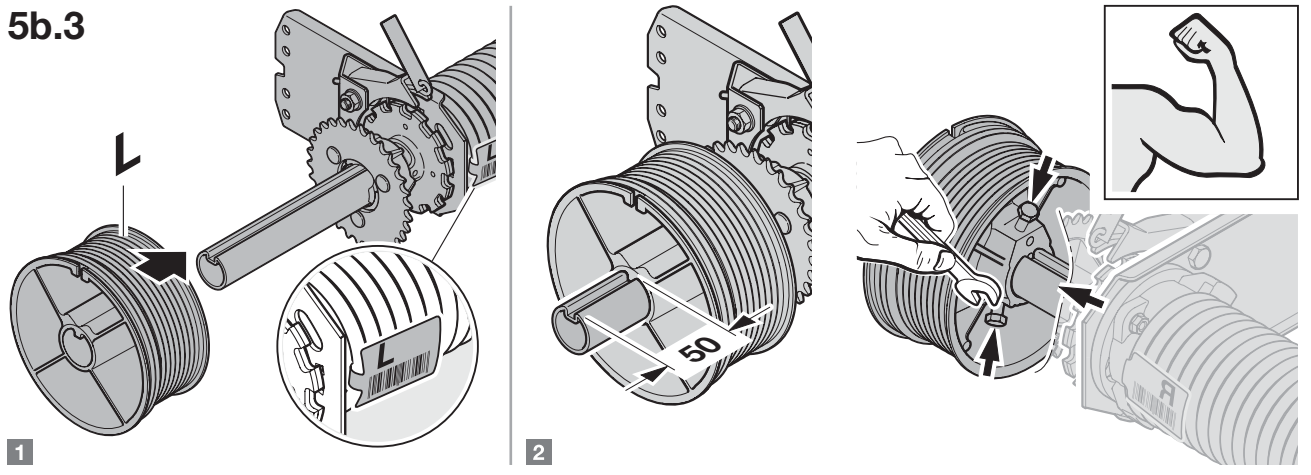

5b.4

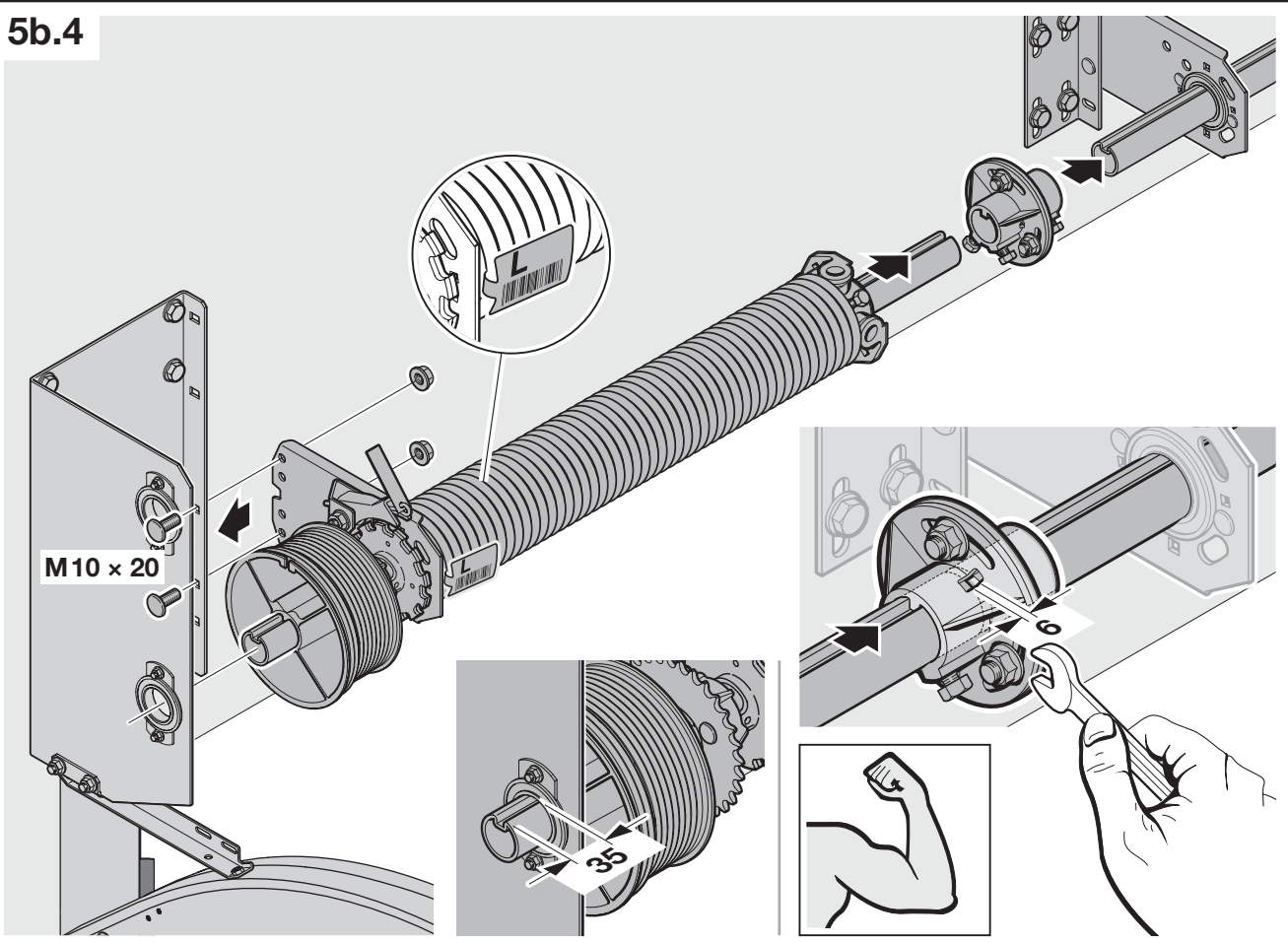

5b.5

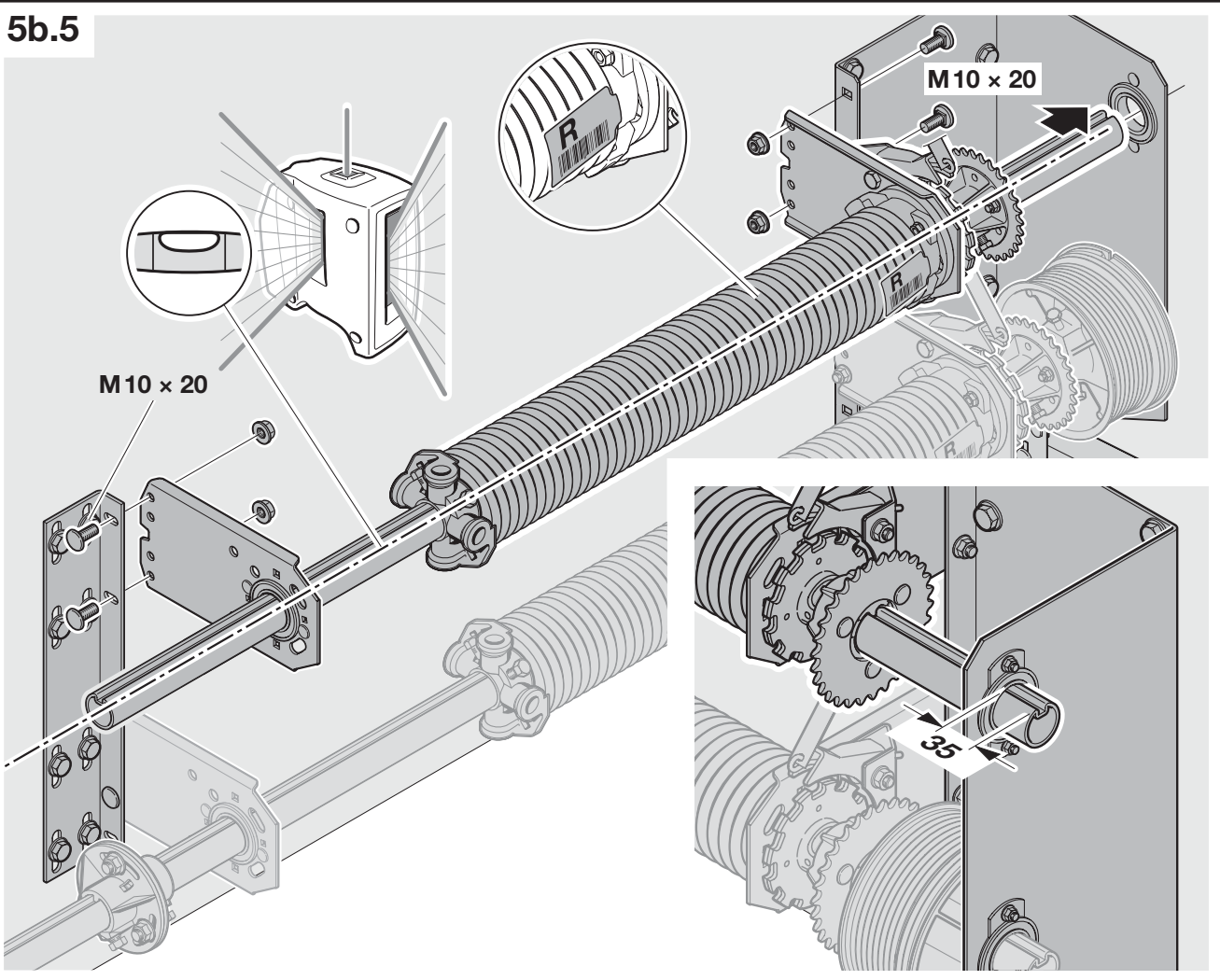

5b.6

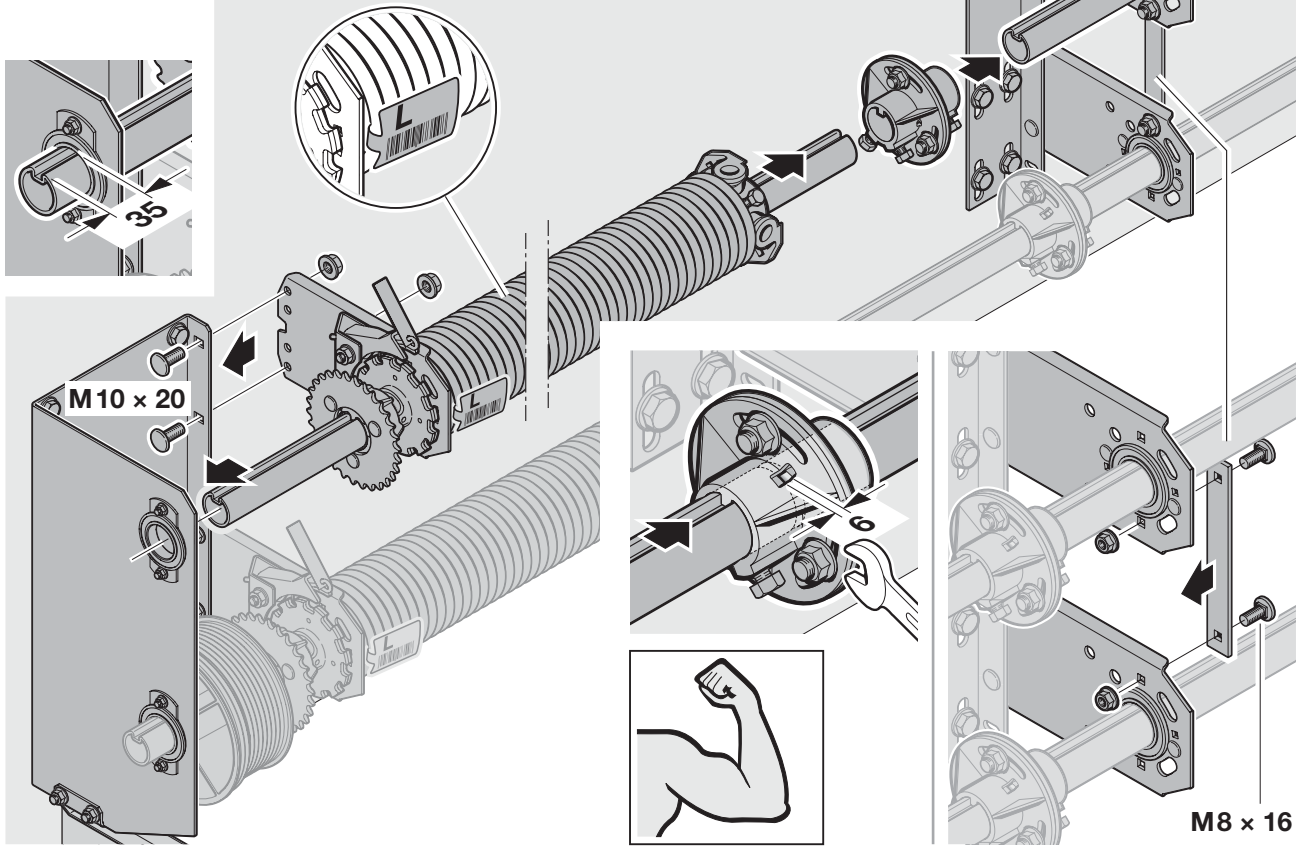

5b.7

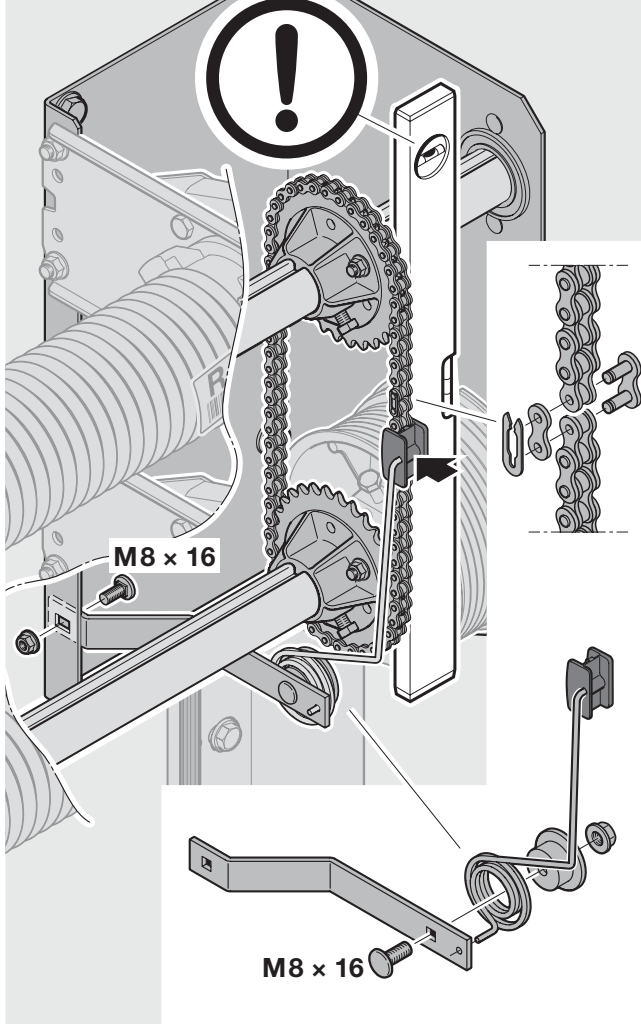

5b.8

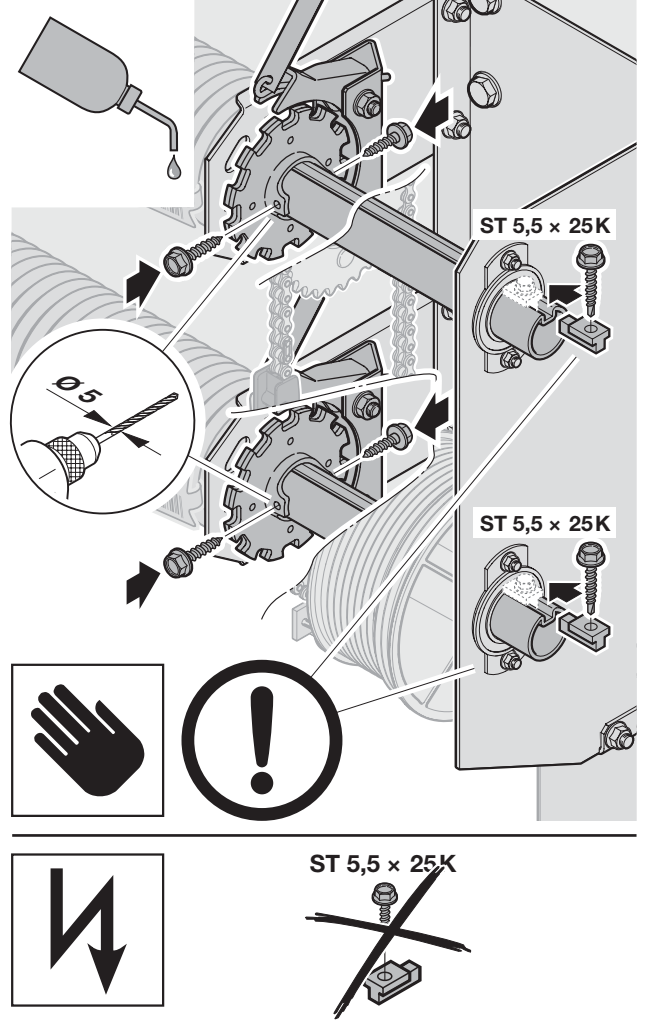

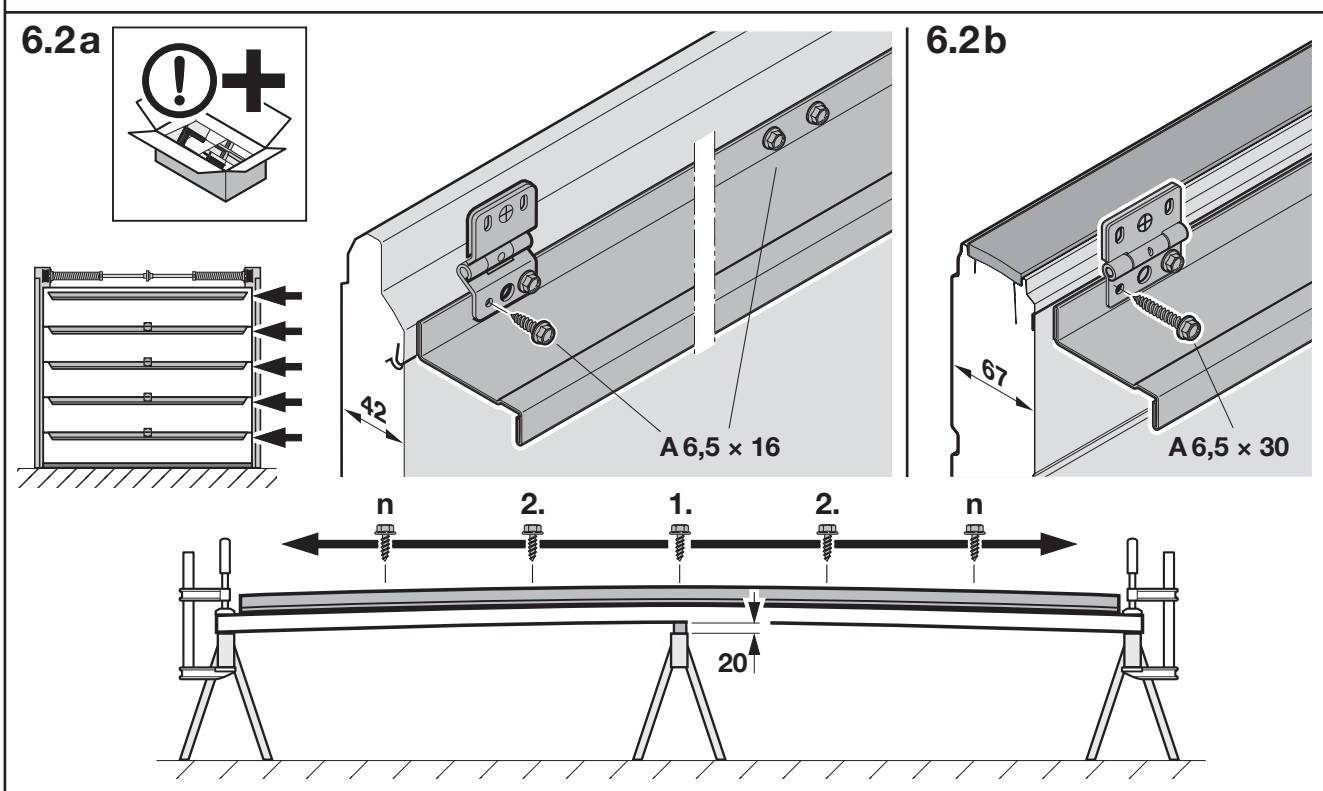
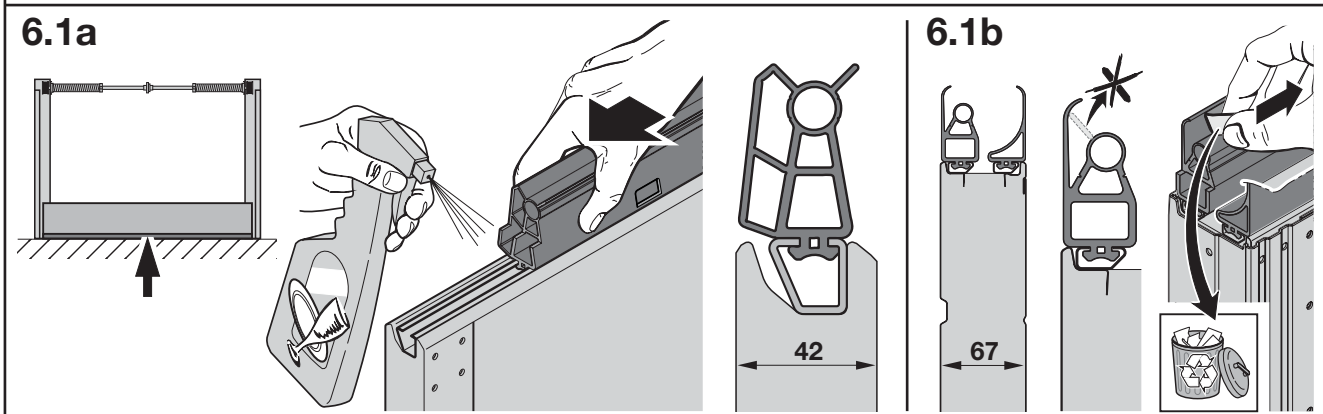
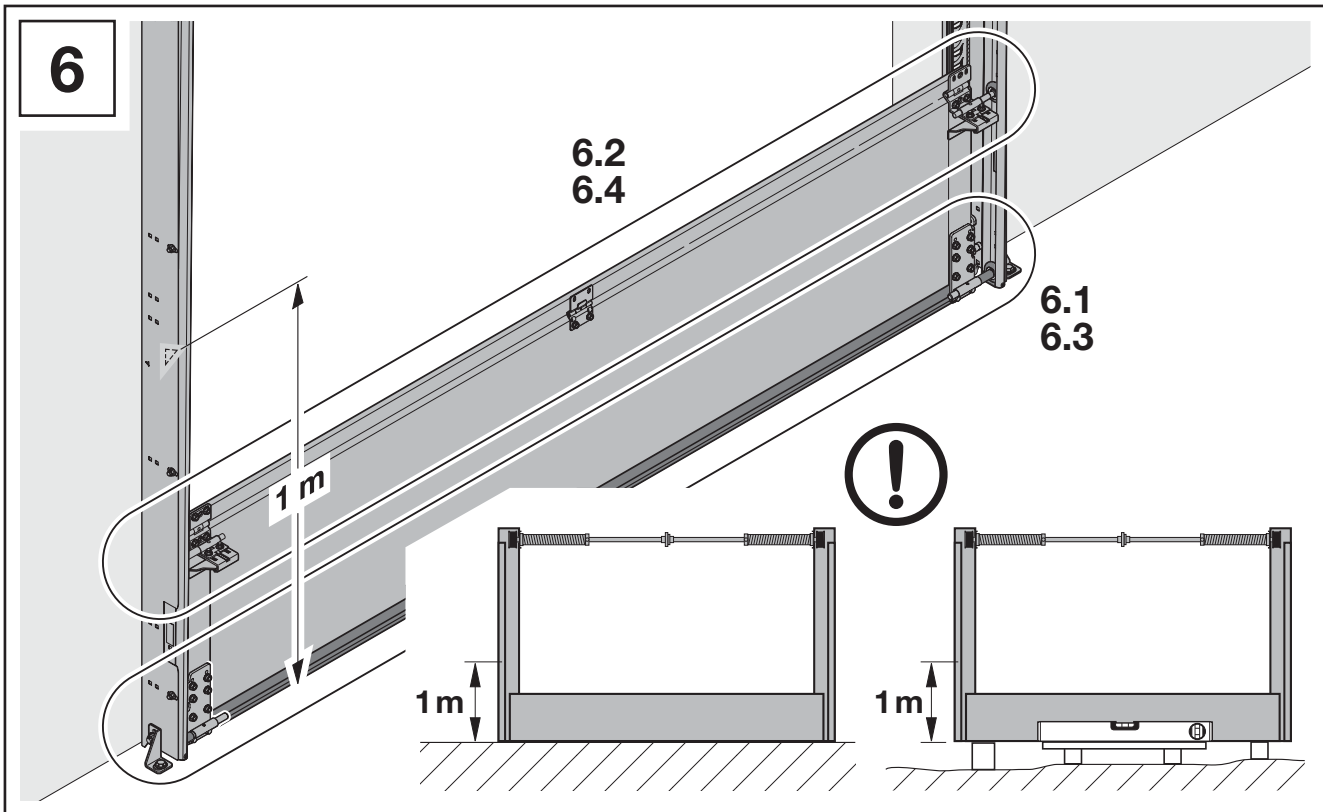



6.3

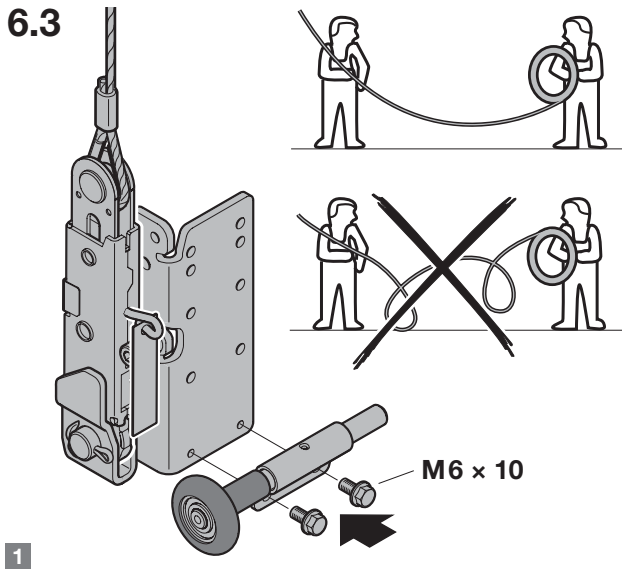

1

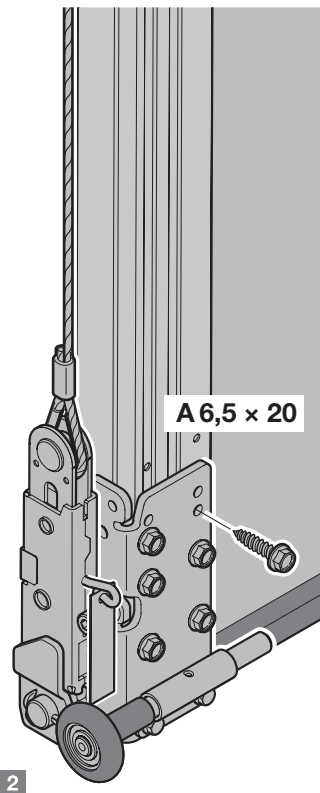

2

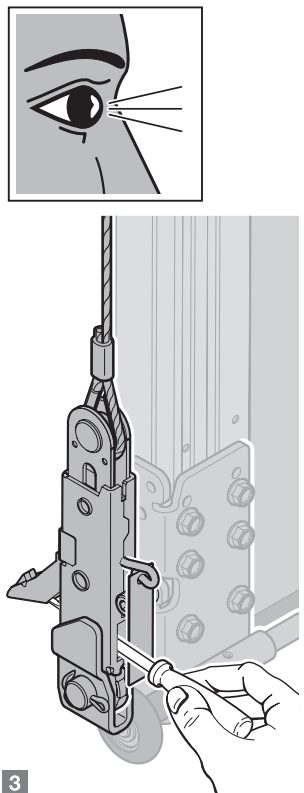

3

6.4a

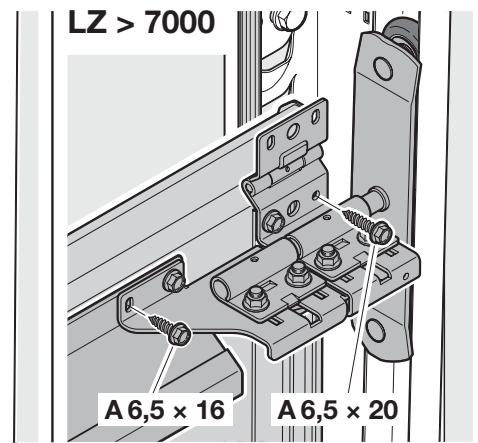
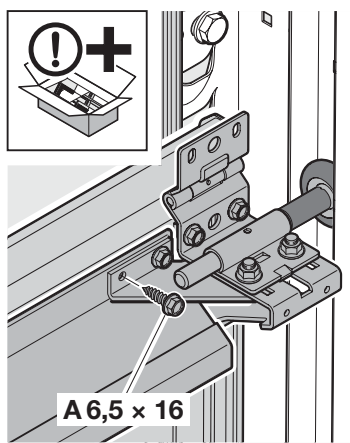
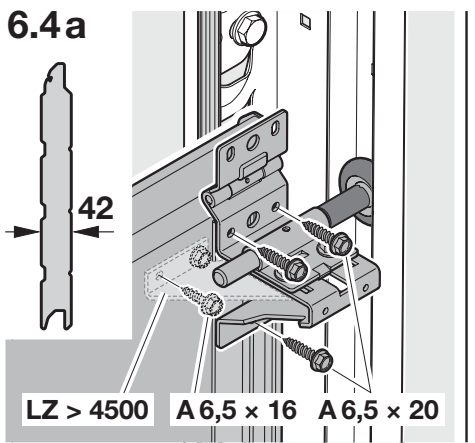

6.4b

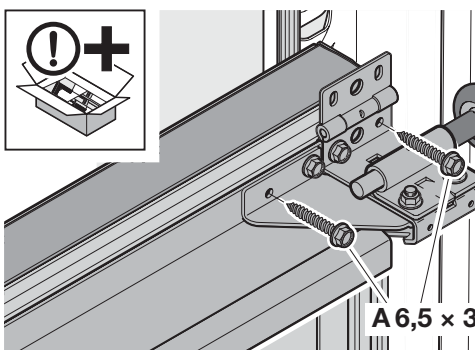
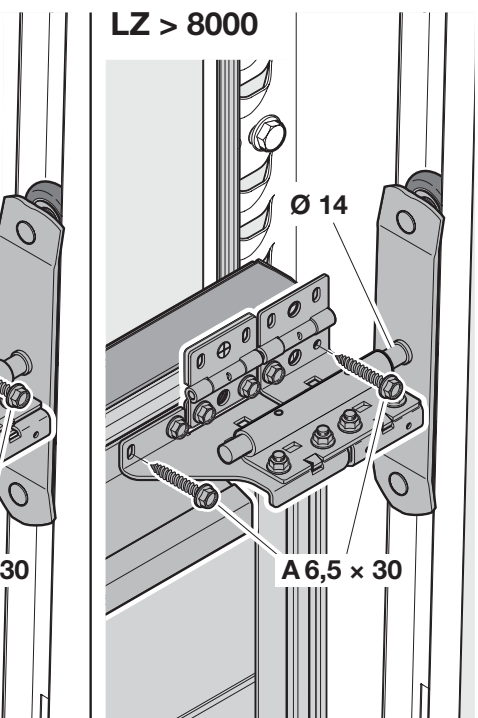
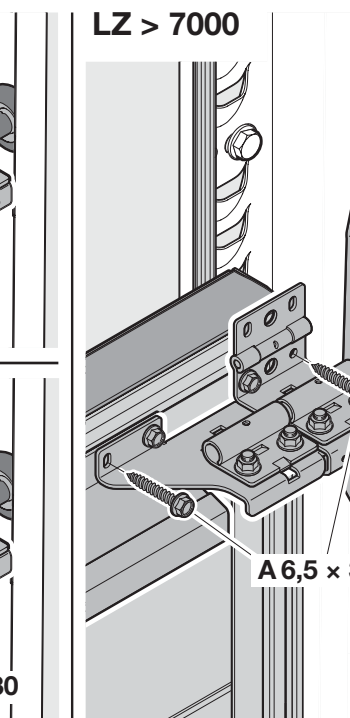
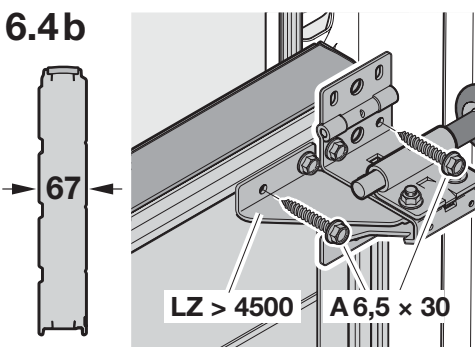

7

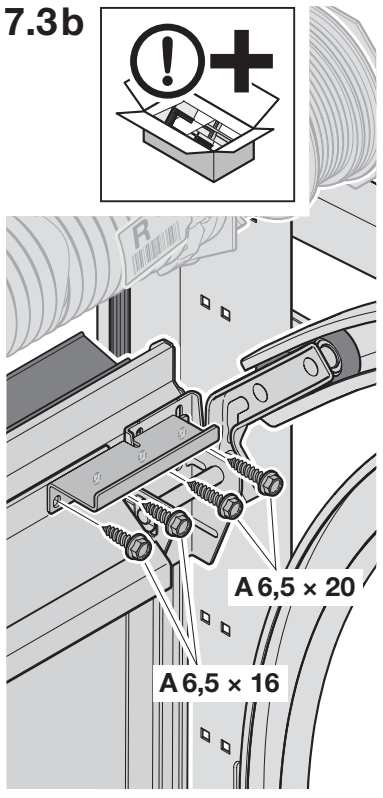
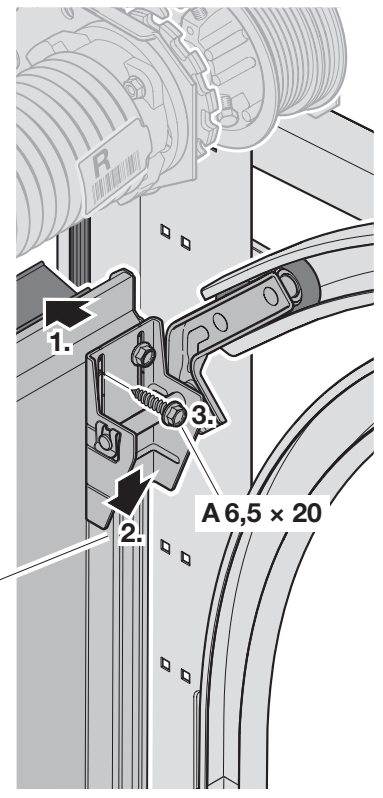
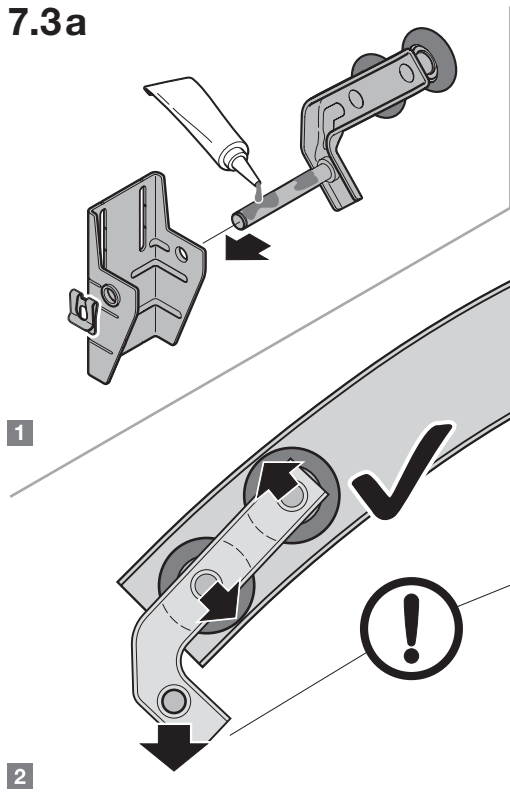
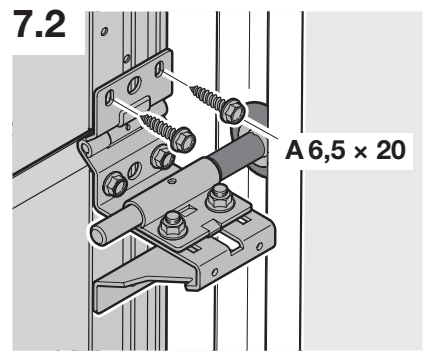
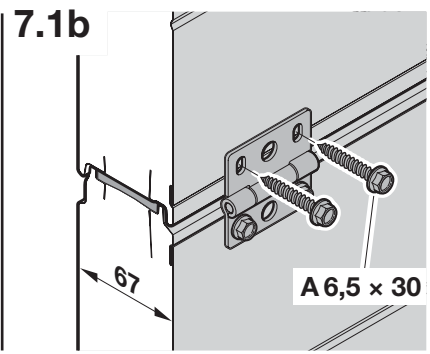
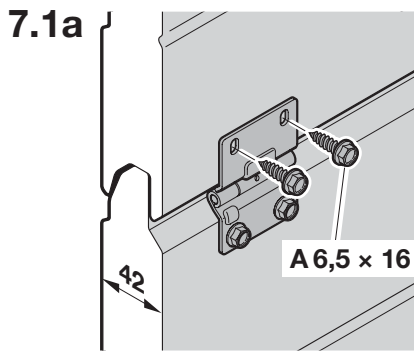
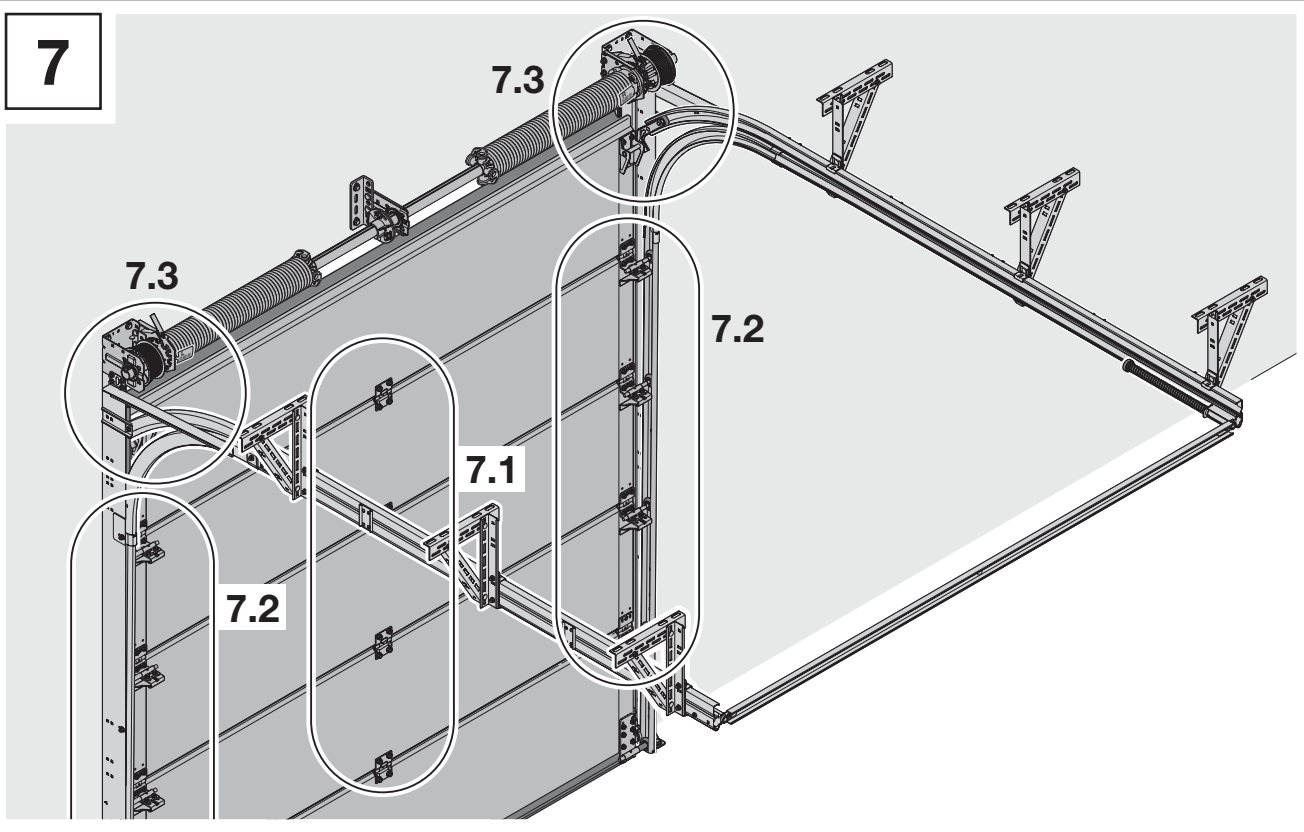

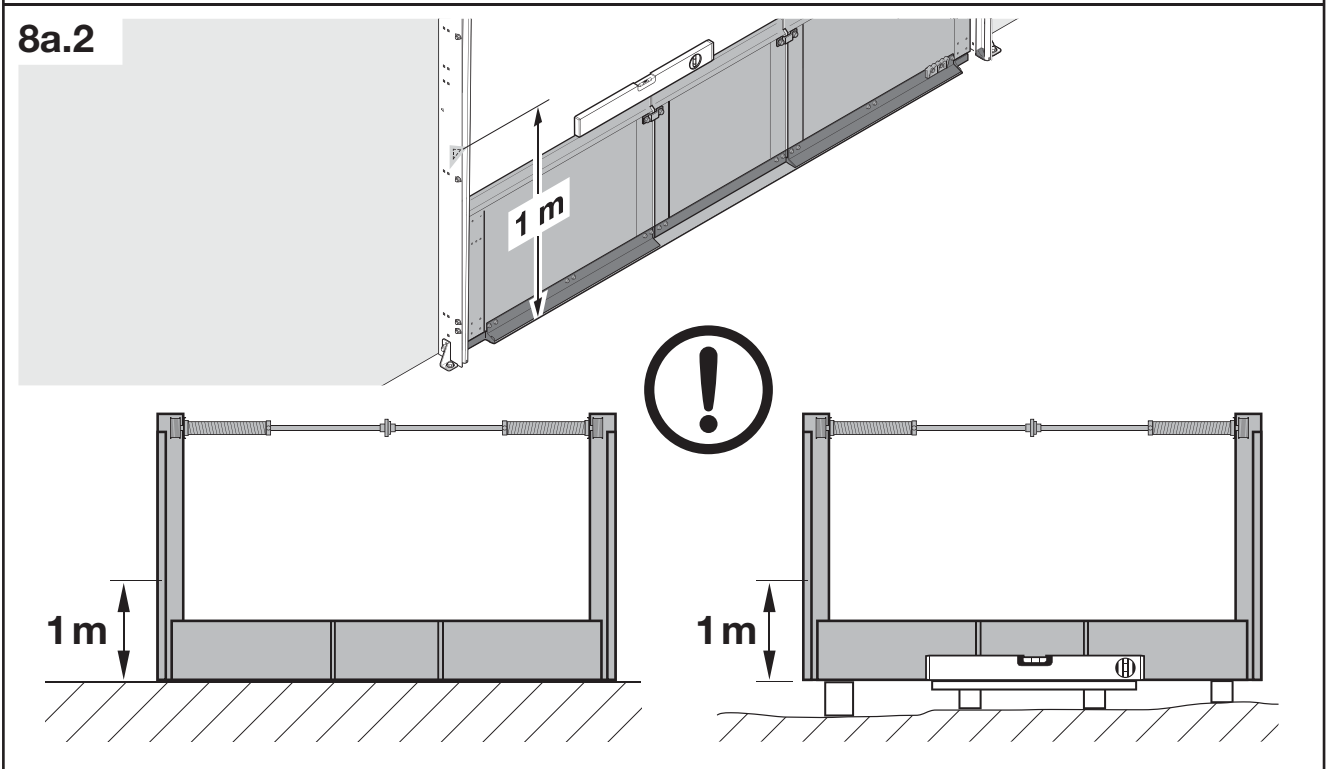
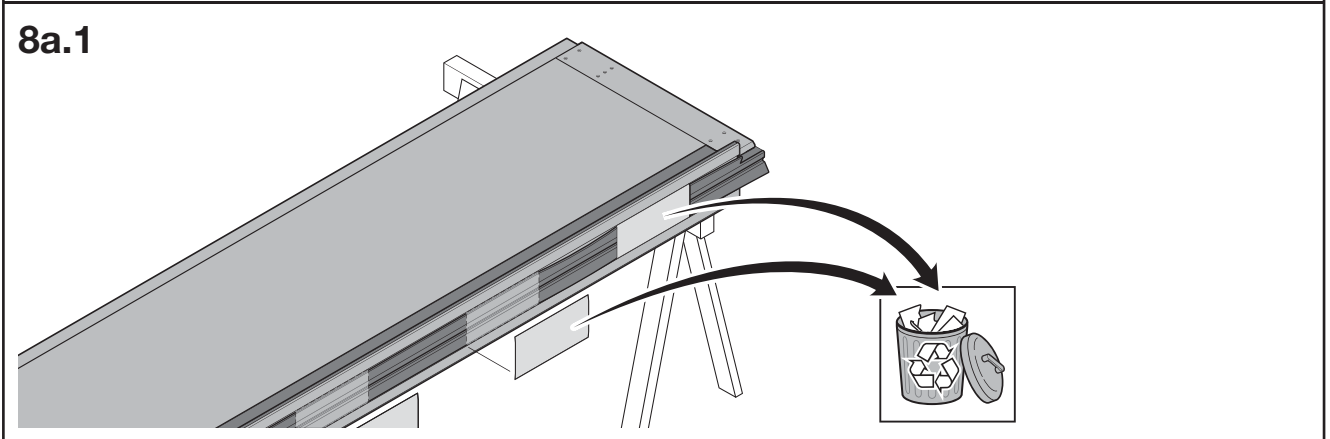
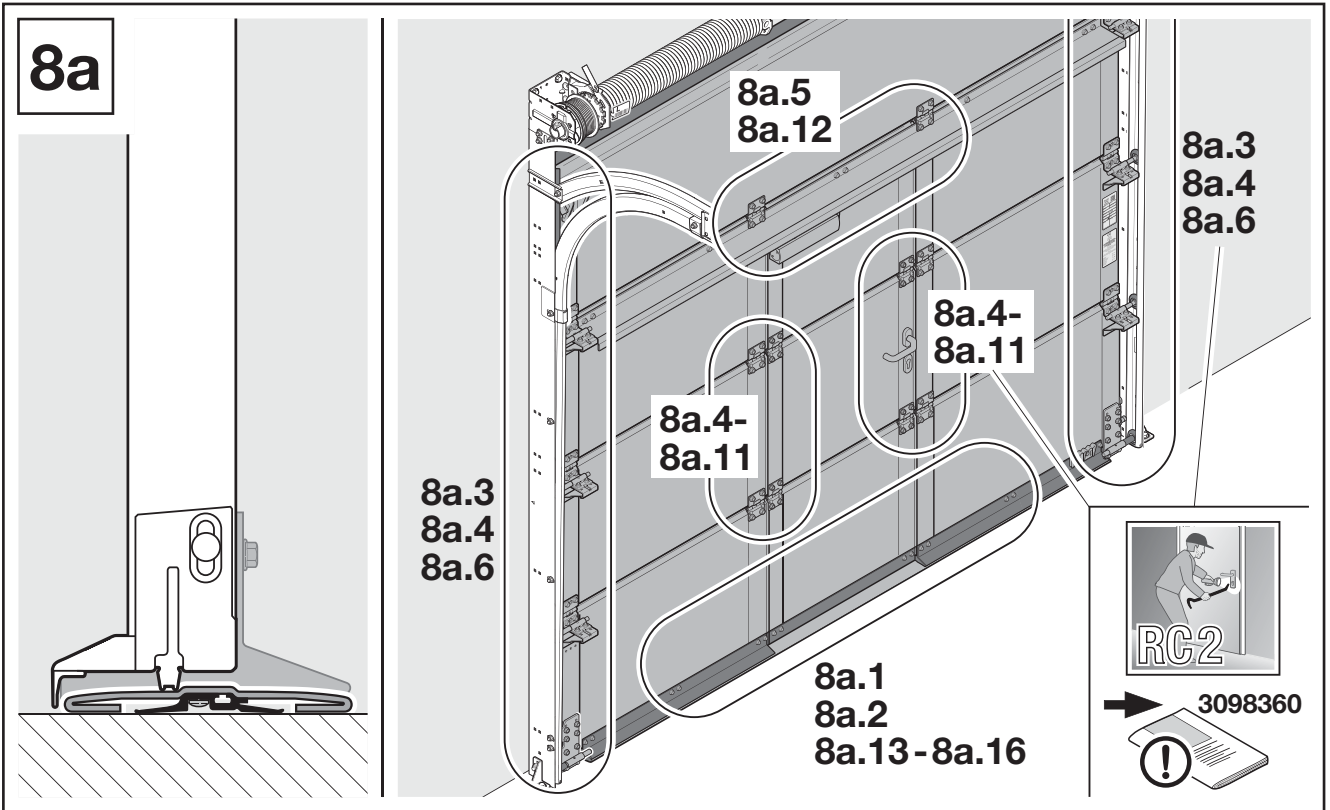

### 8a.3

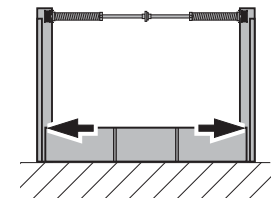

1

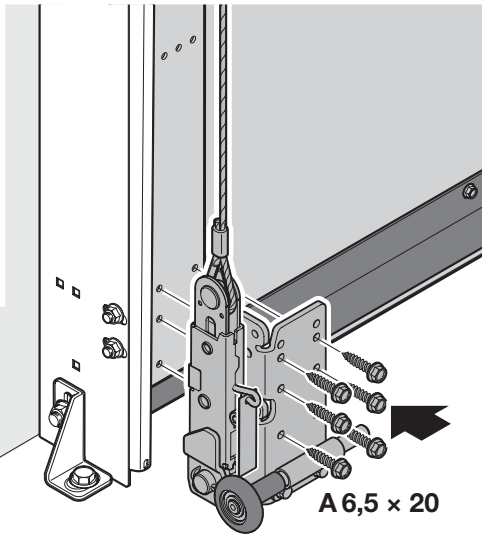

A 6,5 x 20

2

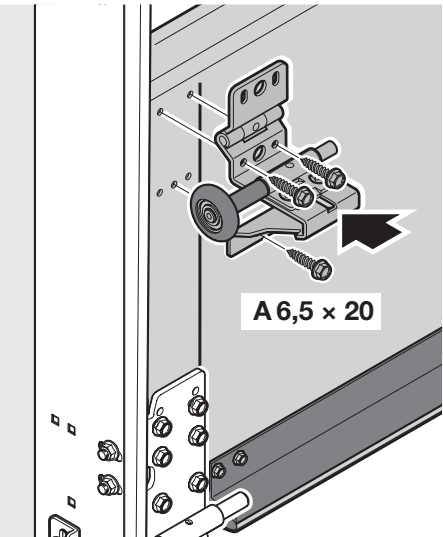

A 6,5 x 20

### 8a.4

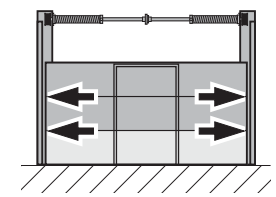

1

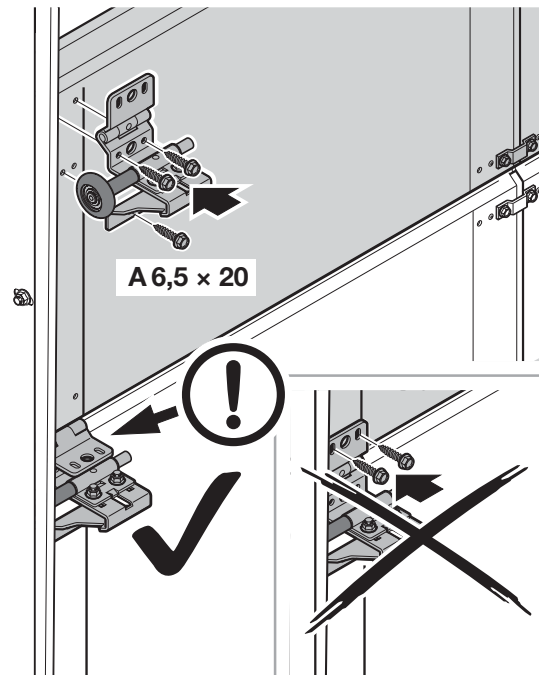

A 6,5 x 20

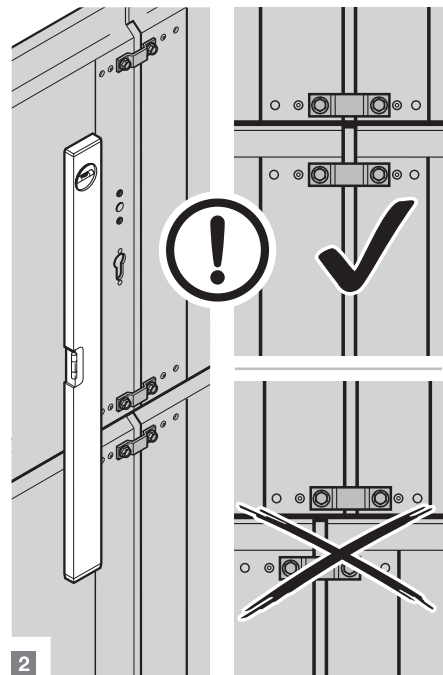

2

### 8a.5

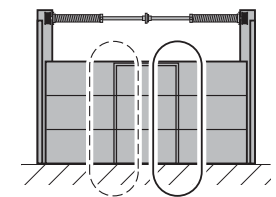

1

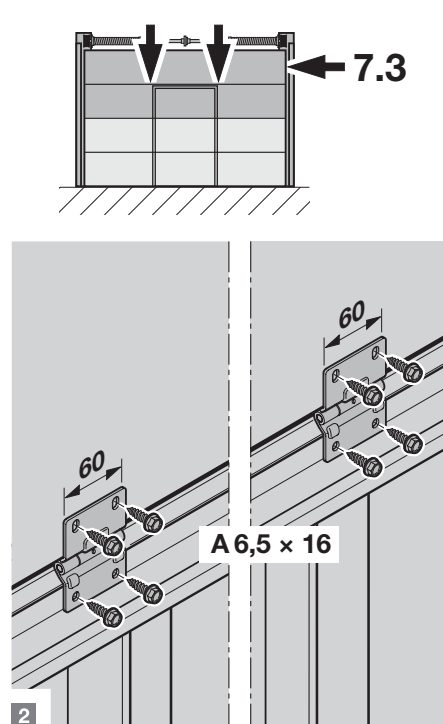
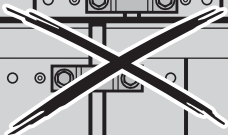
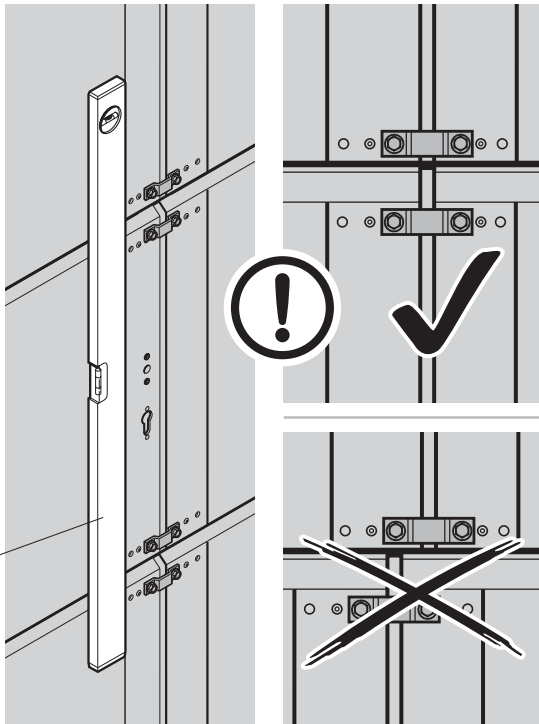

7.3

A 6,5 x 16

2

8a.6

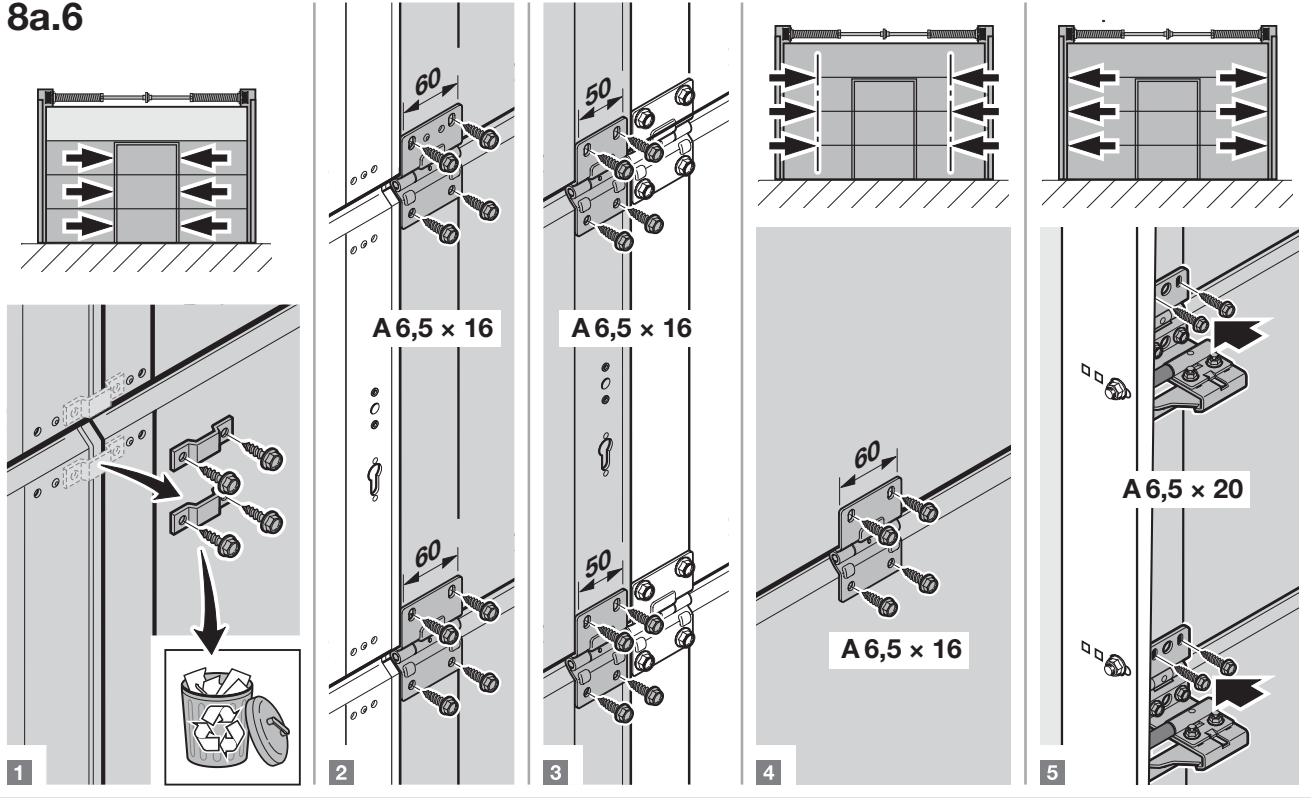

8a.7

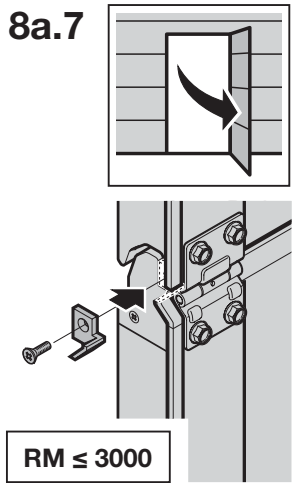

RM ≤ 3000

8a.8

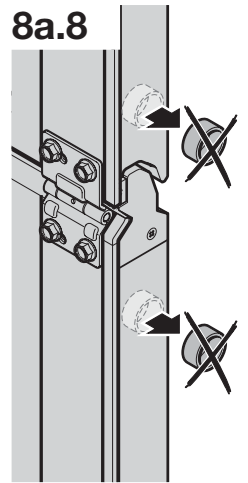

8a.9

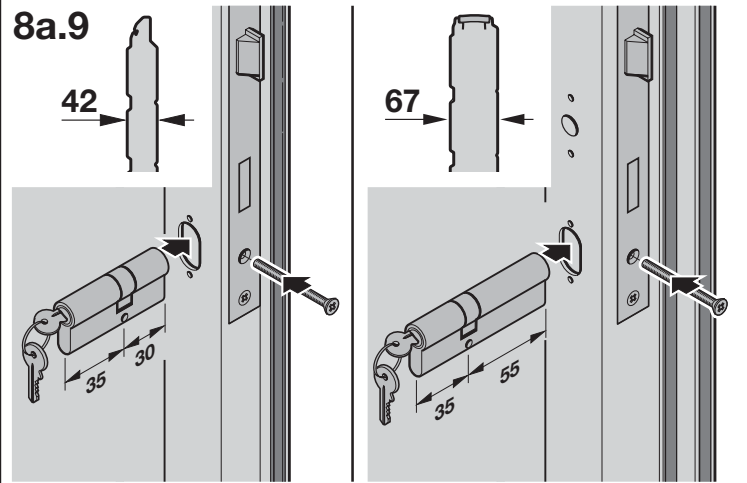

8a.10

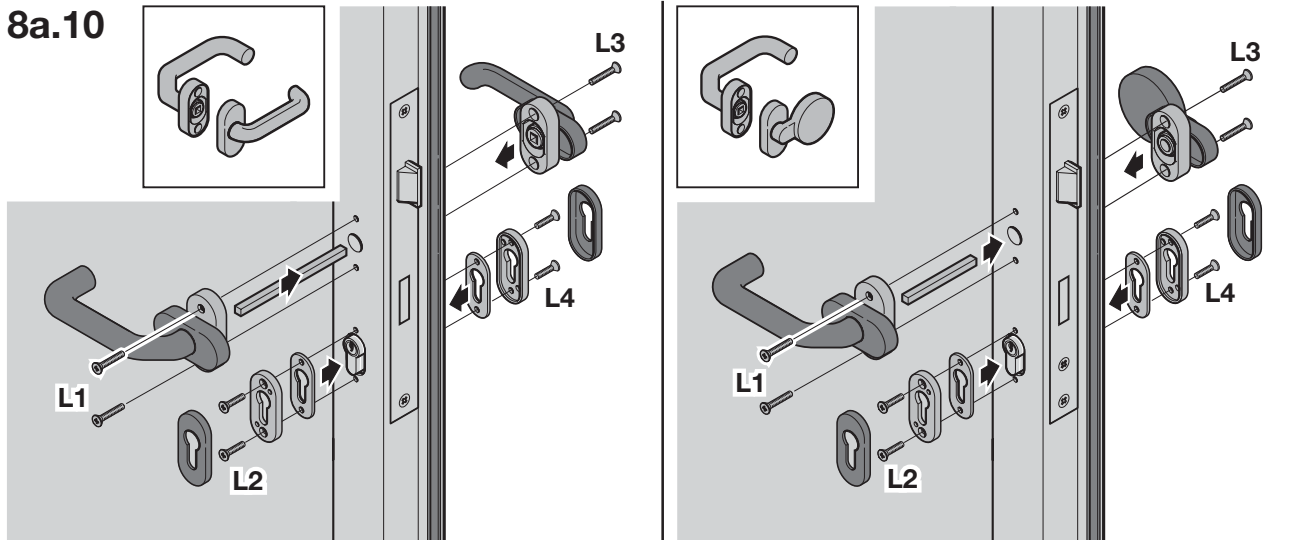

	L1	L2	L3	L4
	25	20	22	16

8a.11

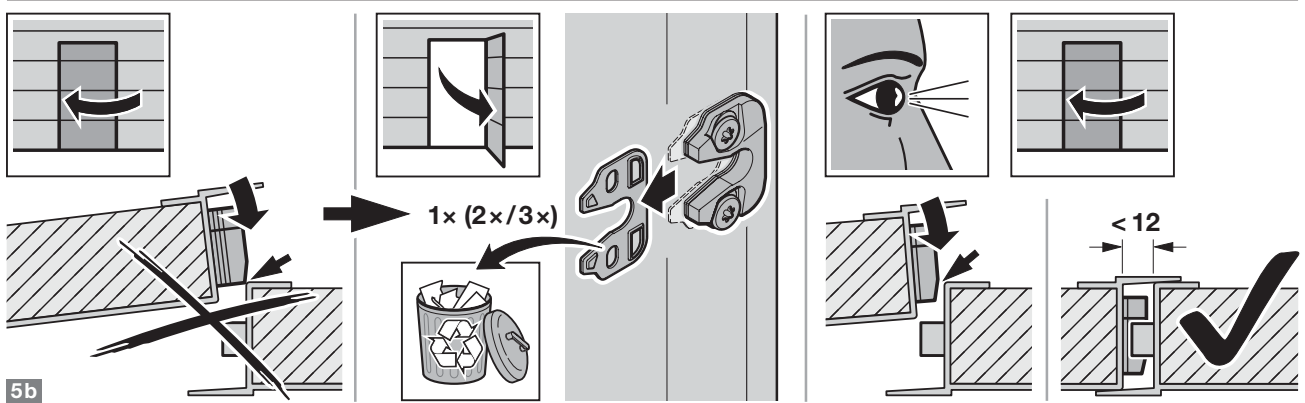
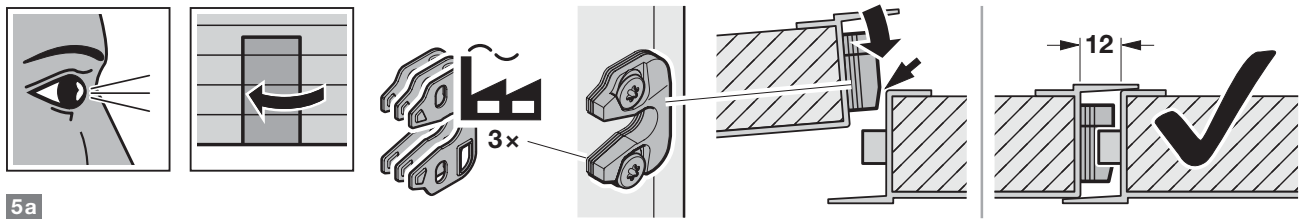
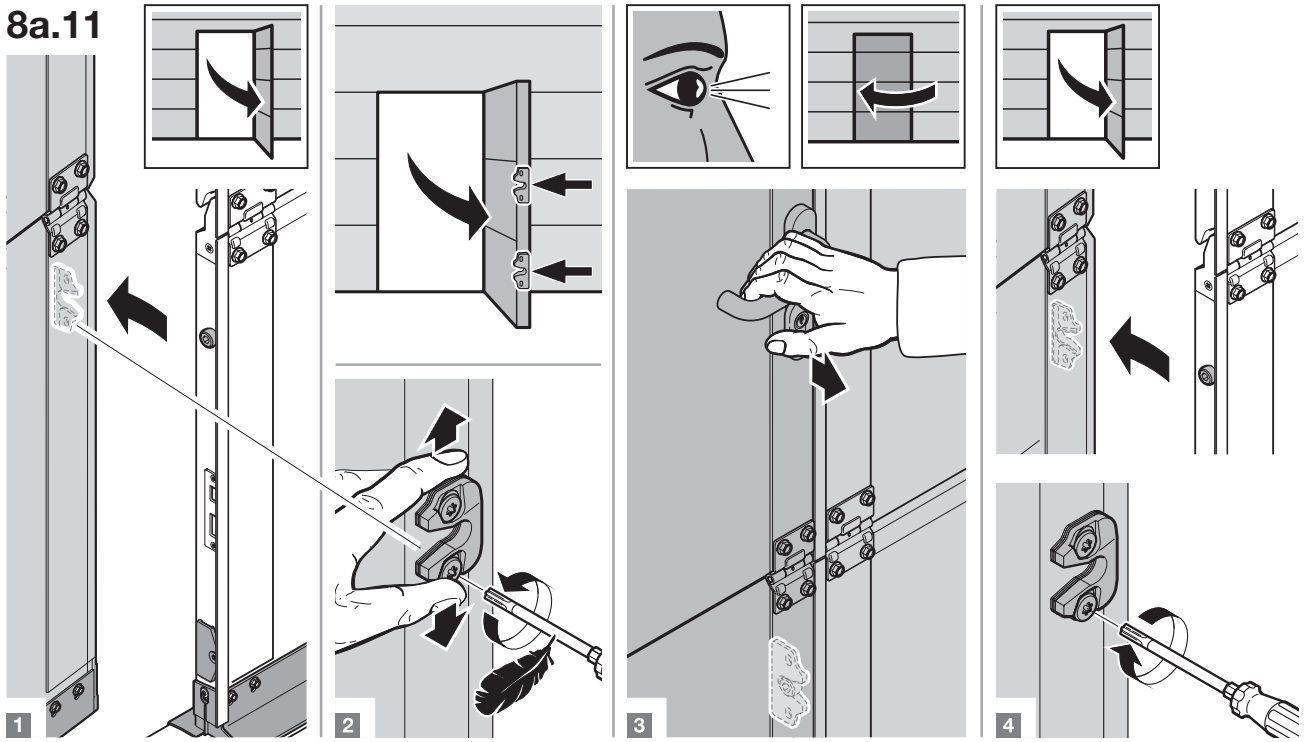

8a.12

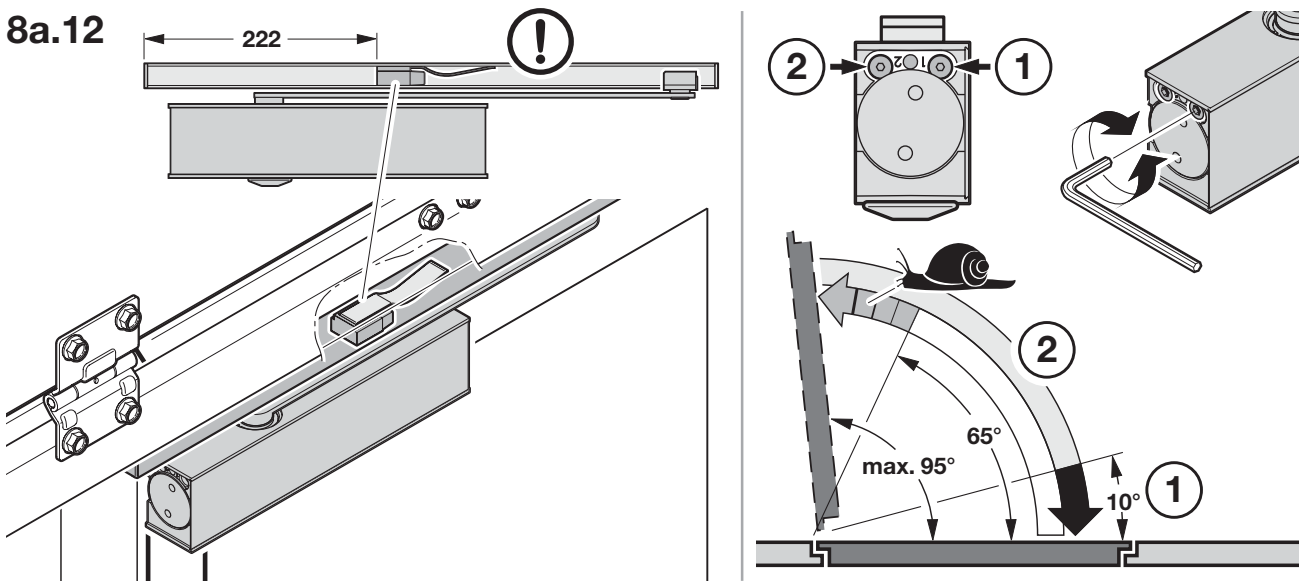

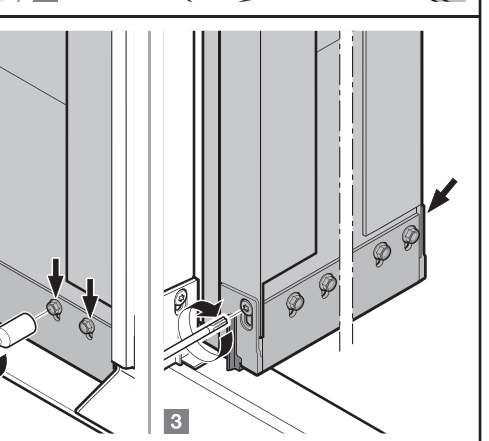
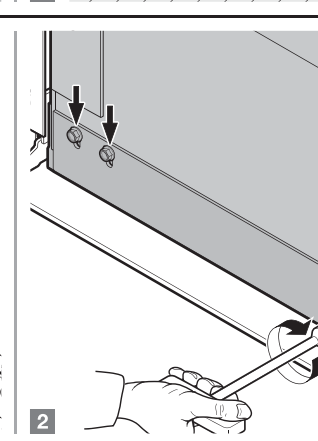
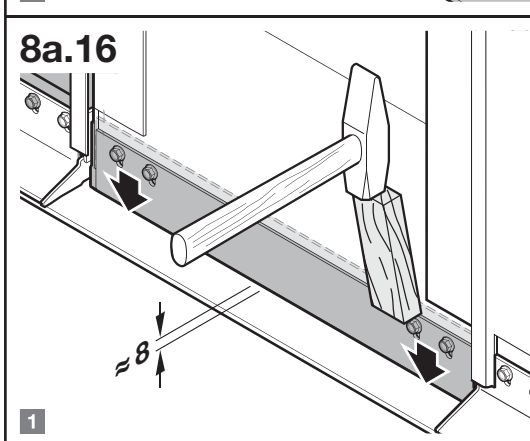
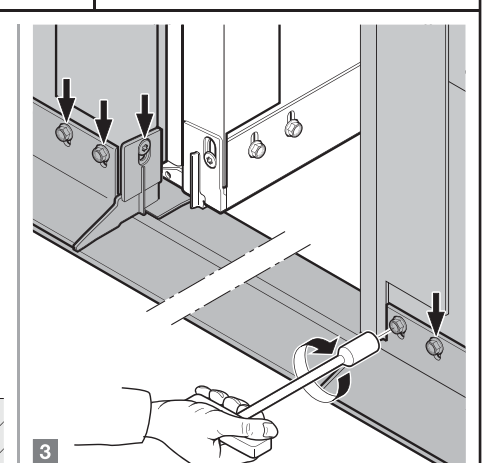
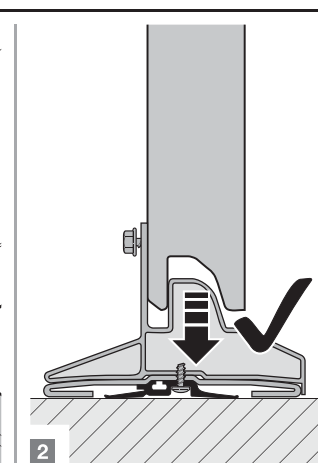
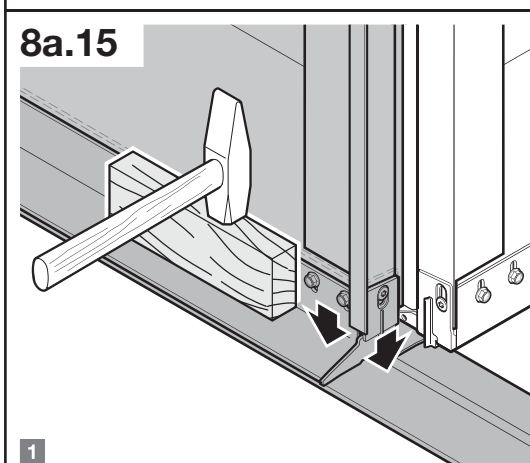
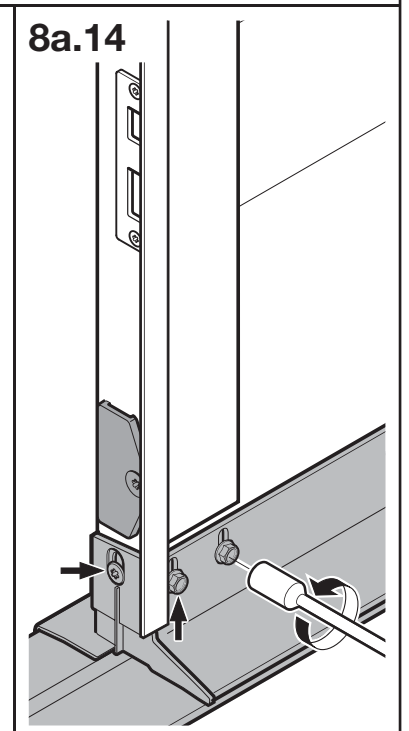
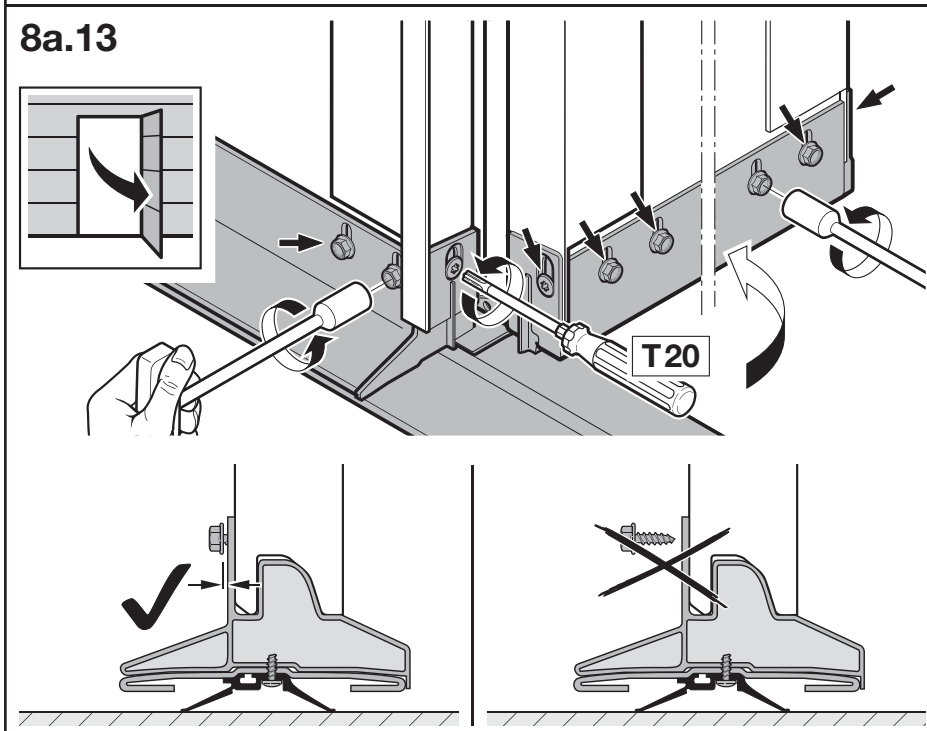
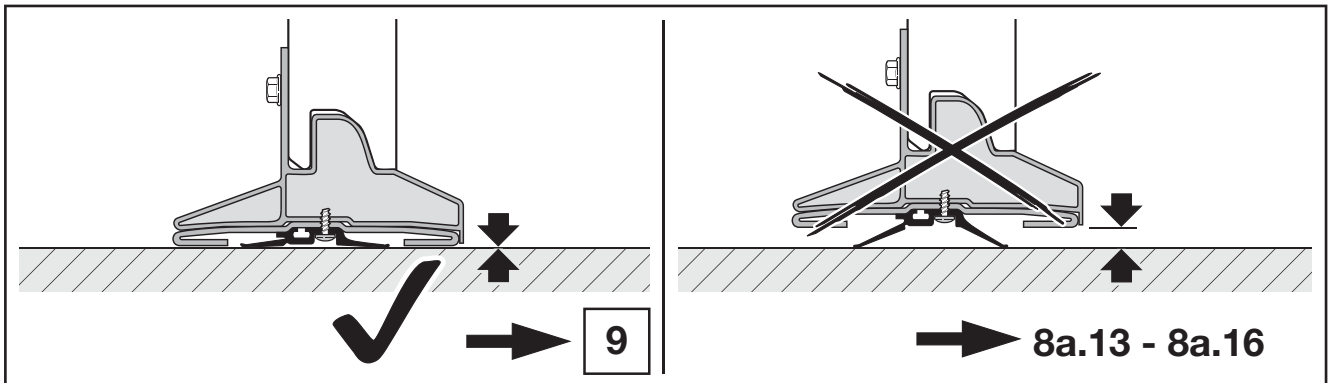

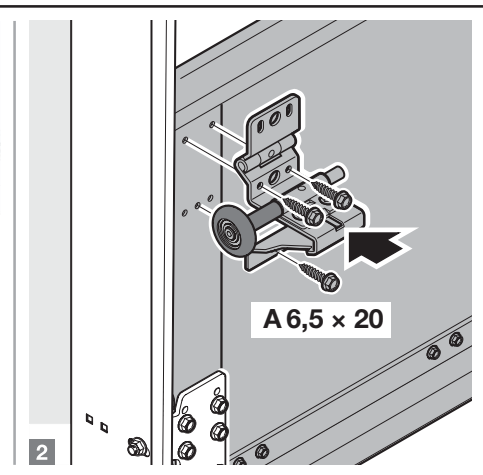
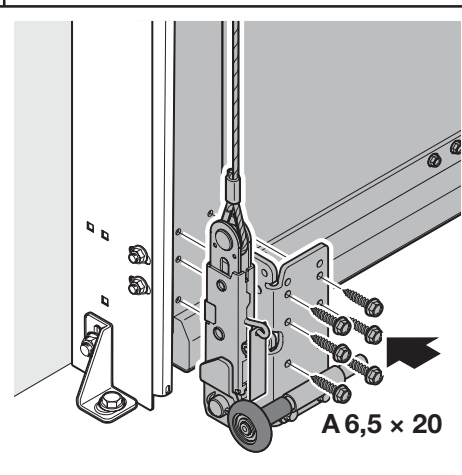
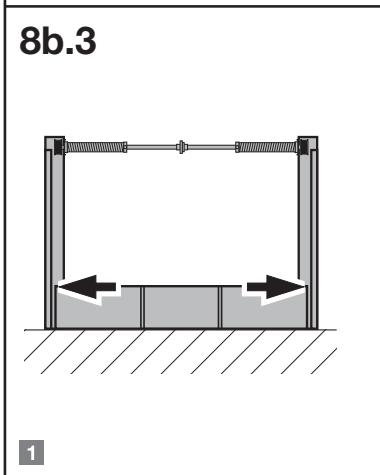
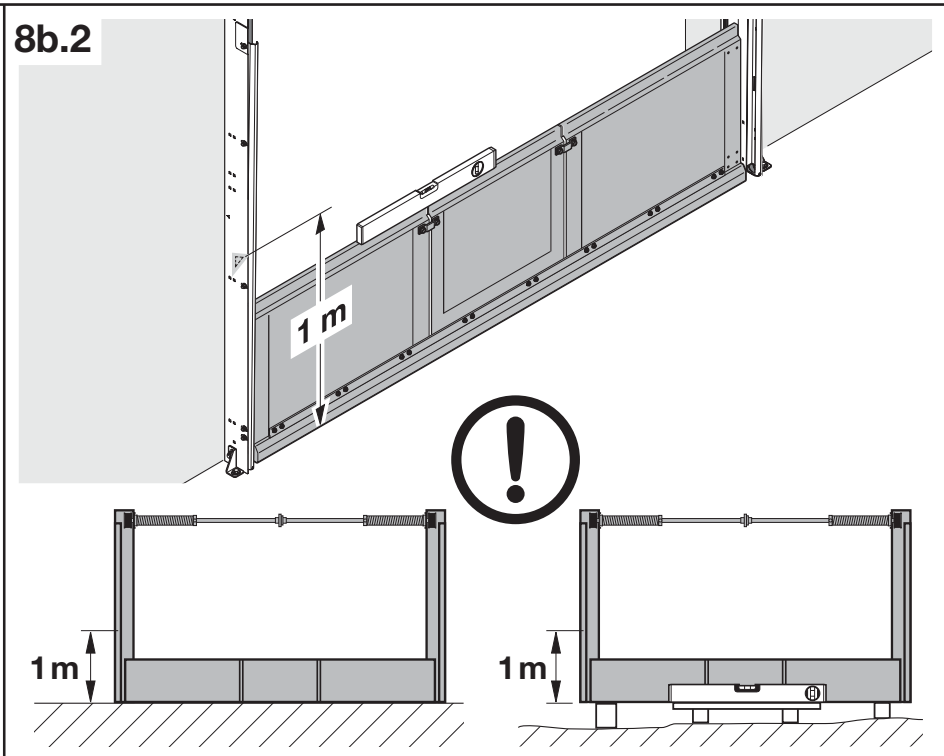
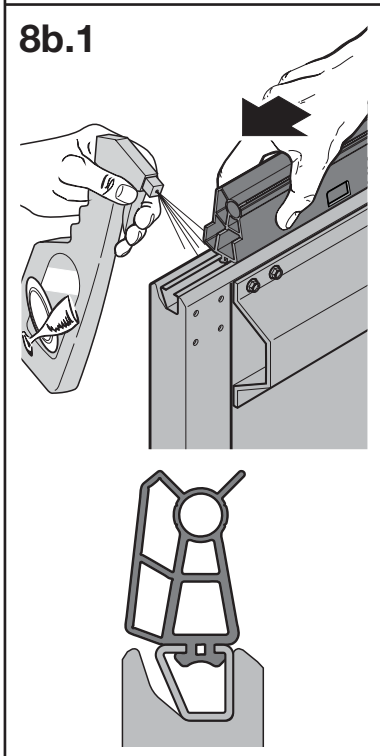
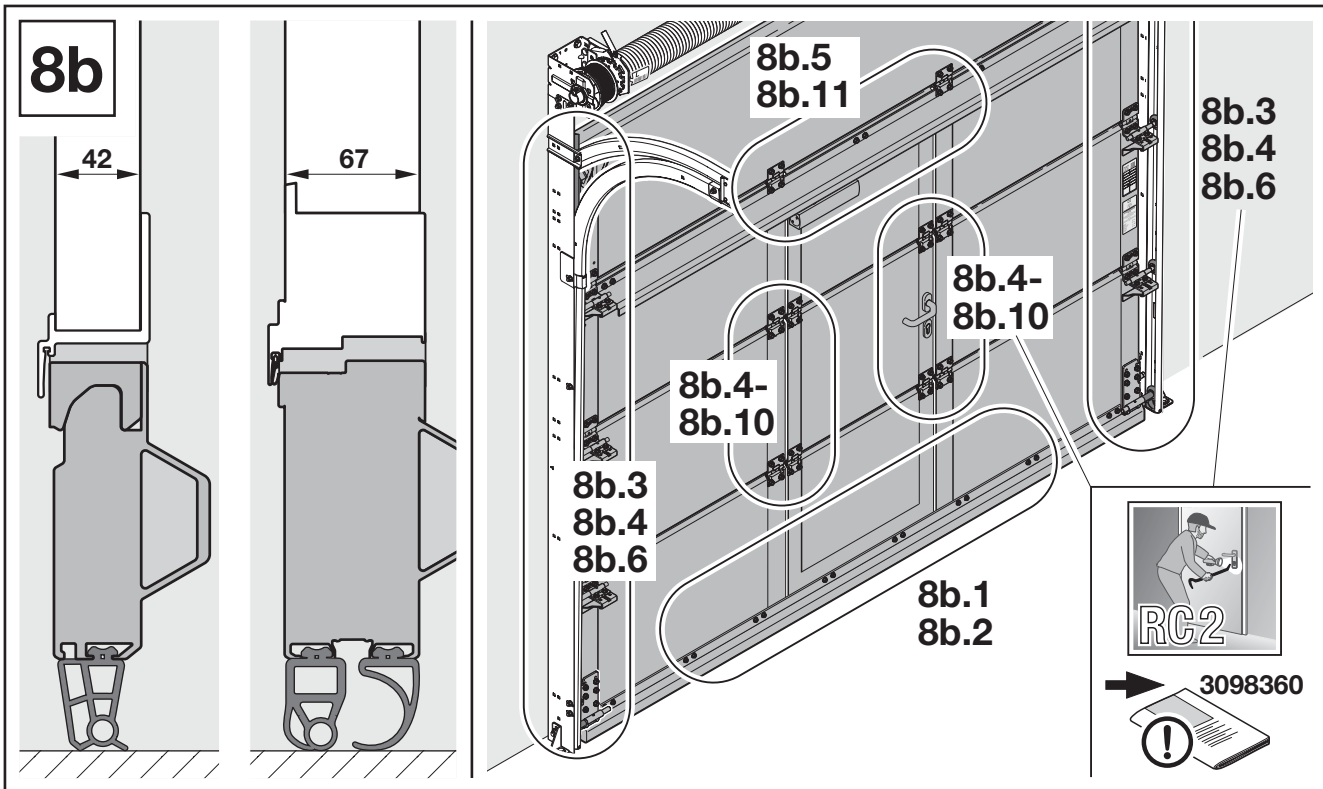



8b.4

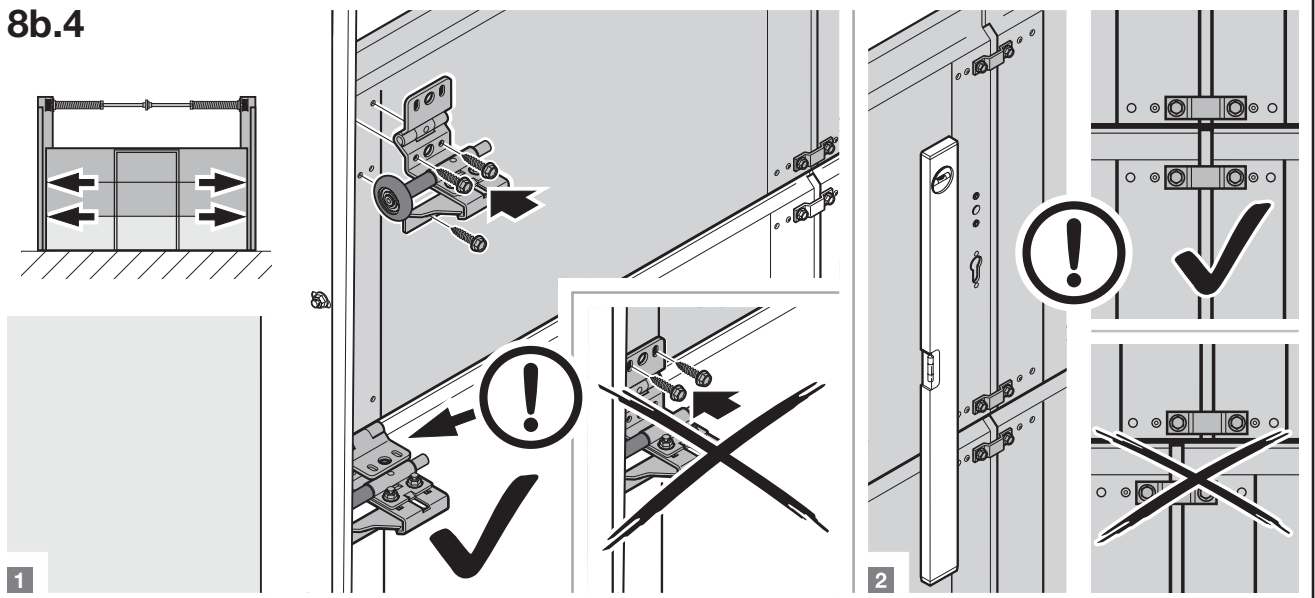

8b.5

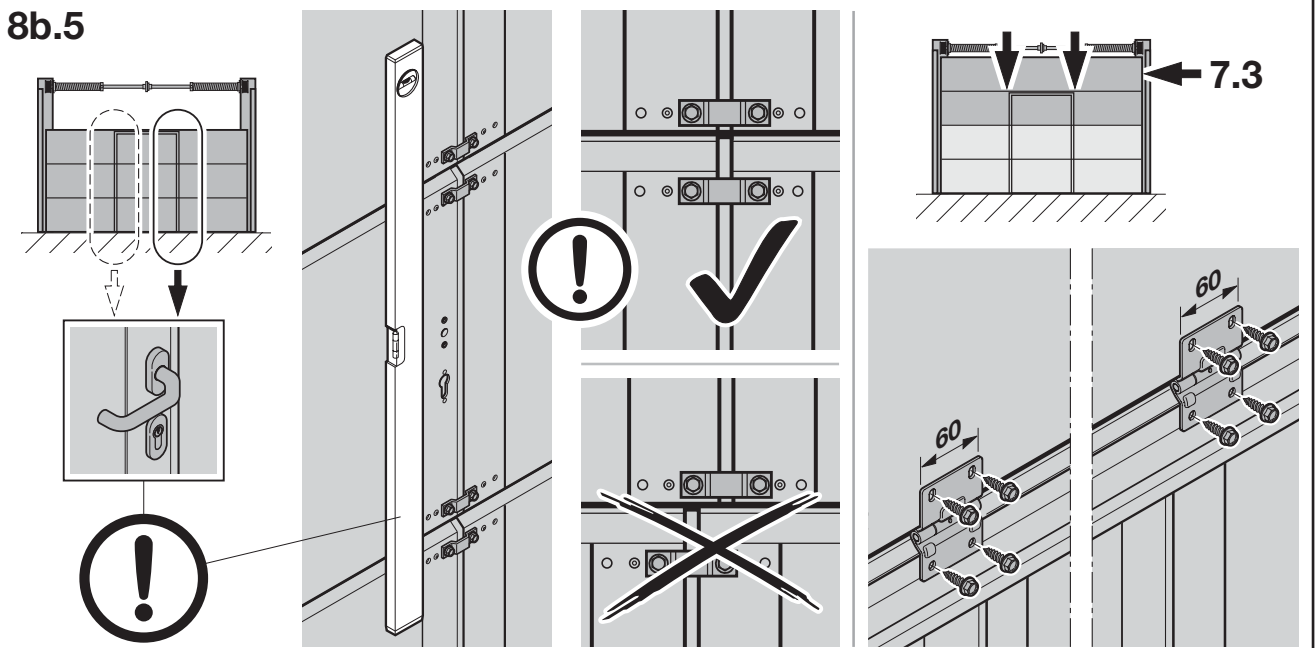

8b.6

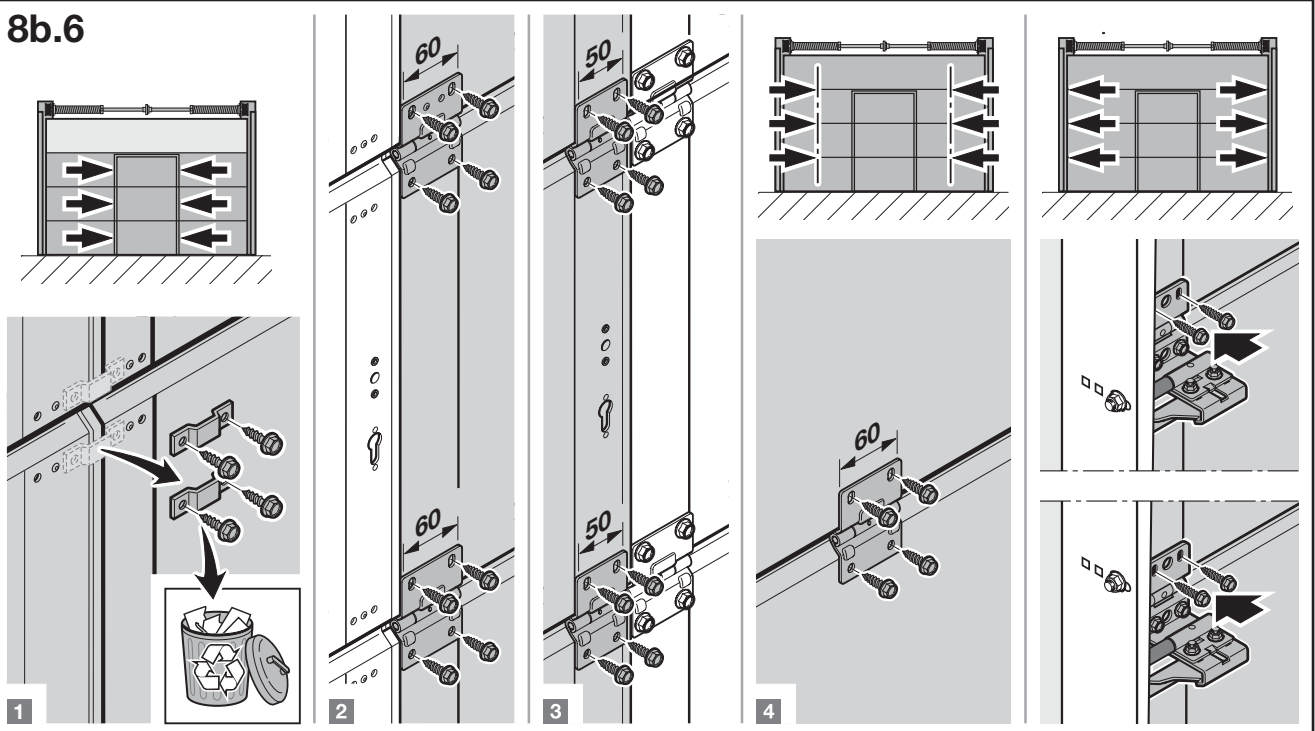

8b.7

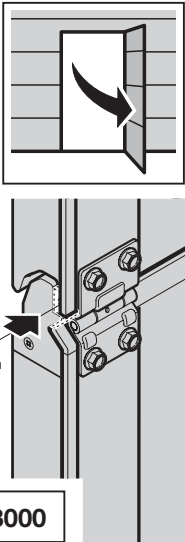

RM ≤ 3000

8b.8

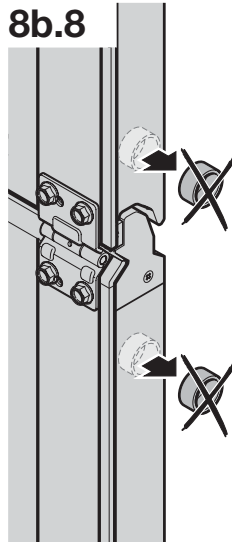

8b.9

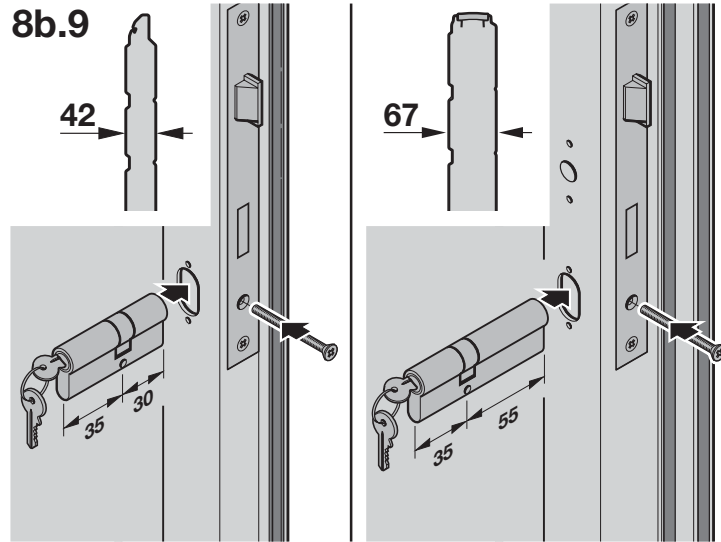

8b.10

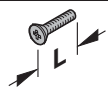
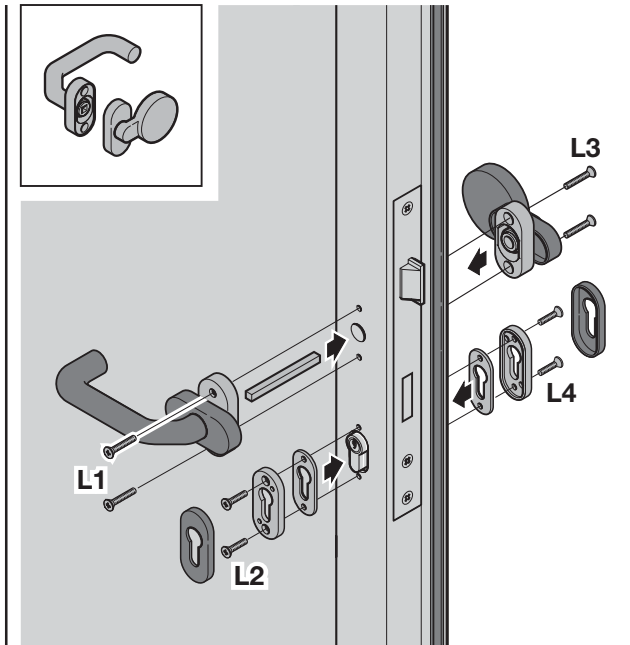
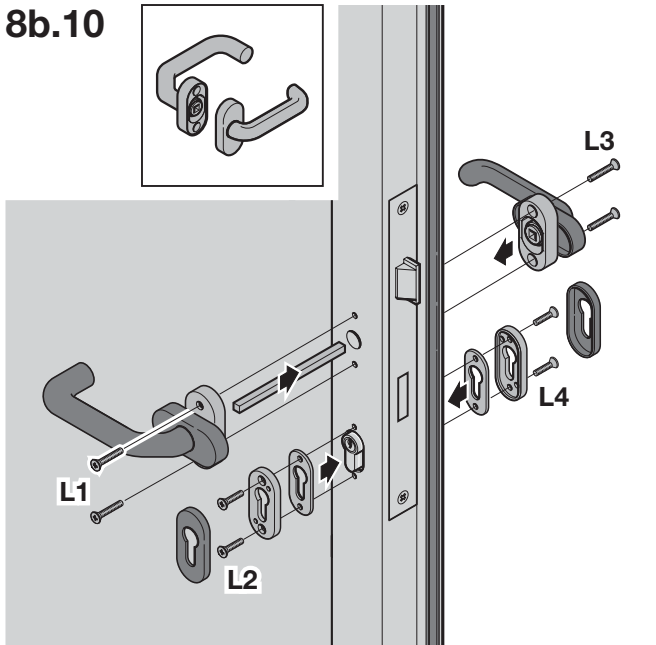

L1

25

L2

20

L3

22

L4

16

8b.11

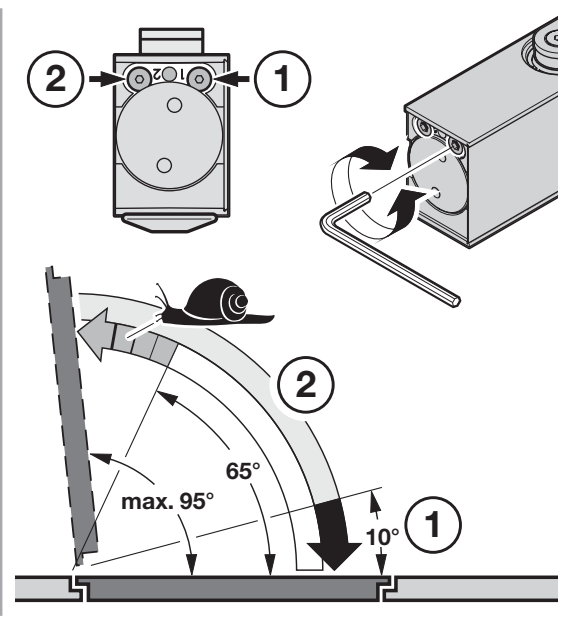
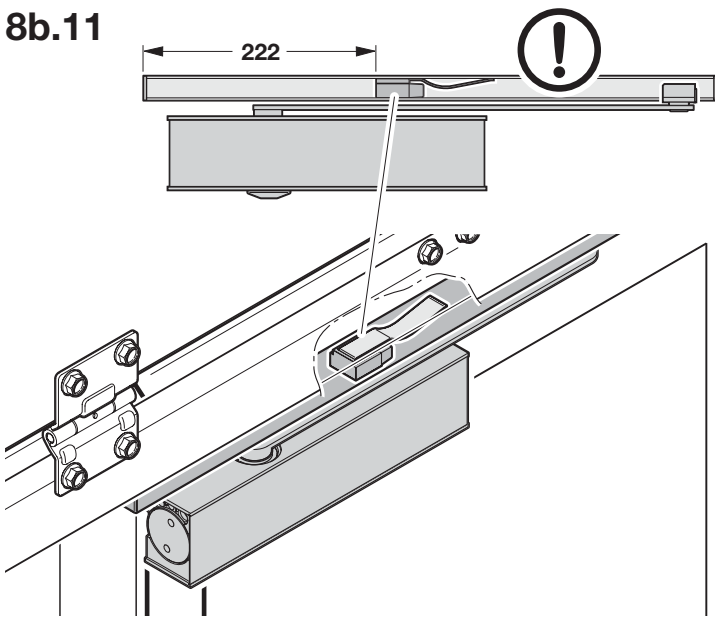

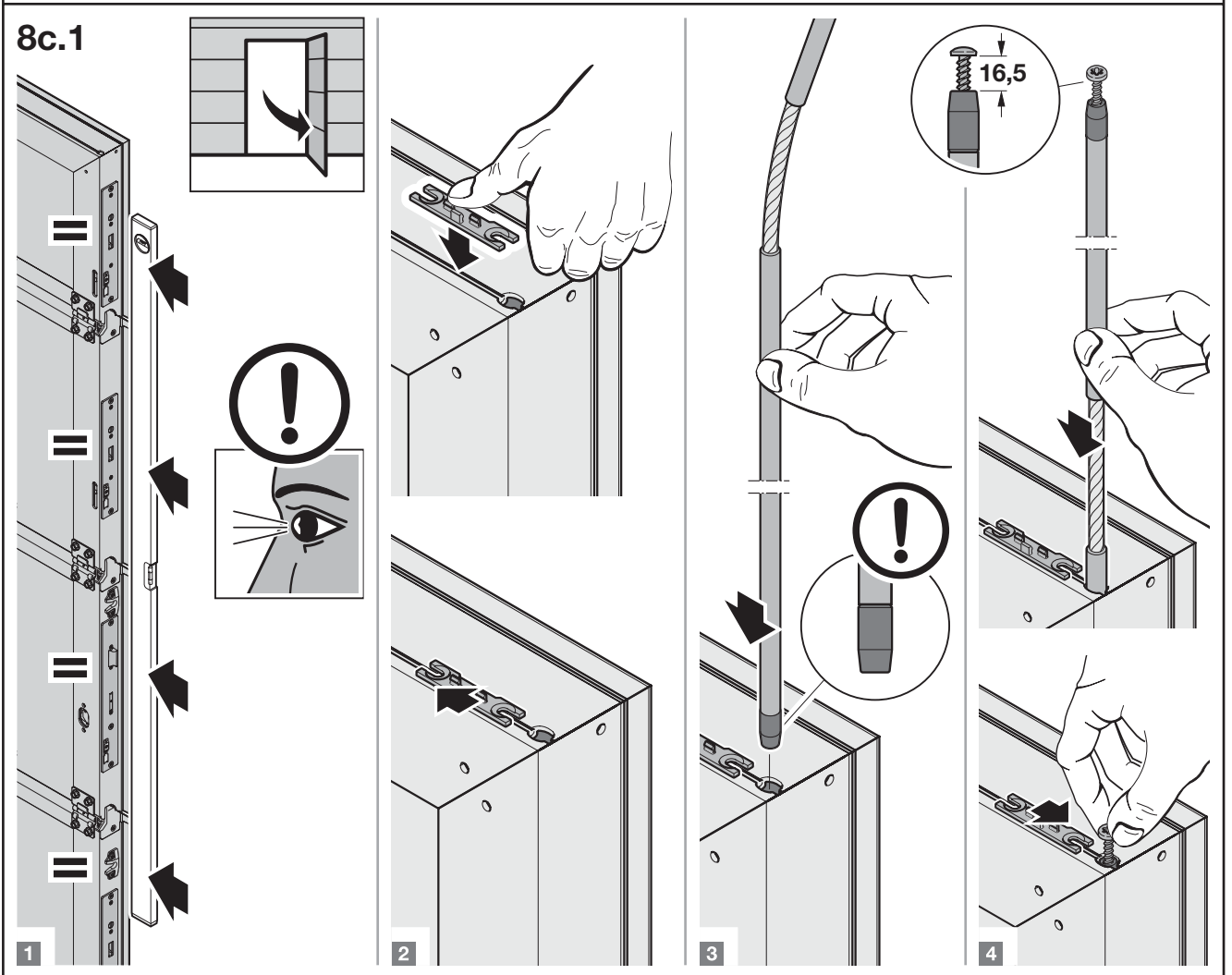
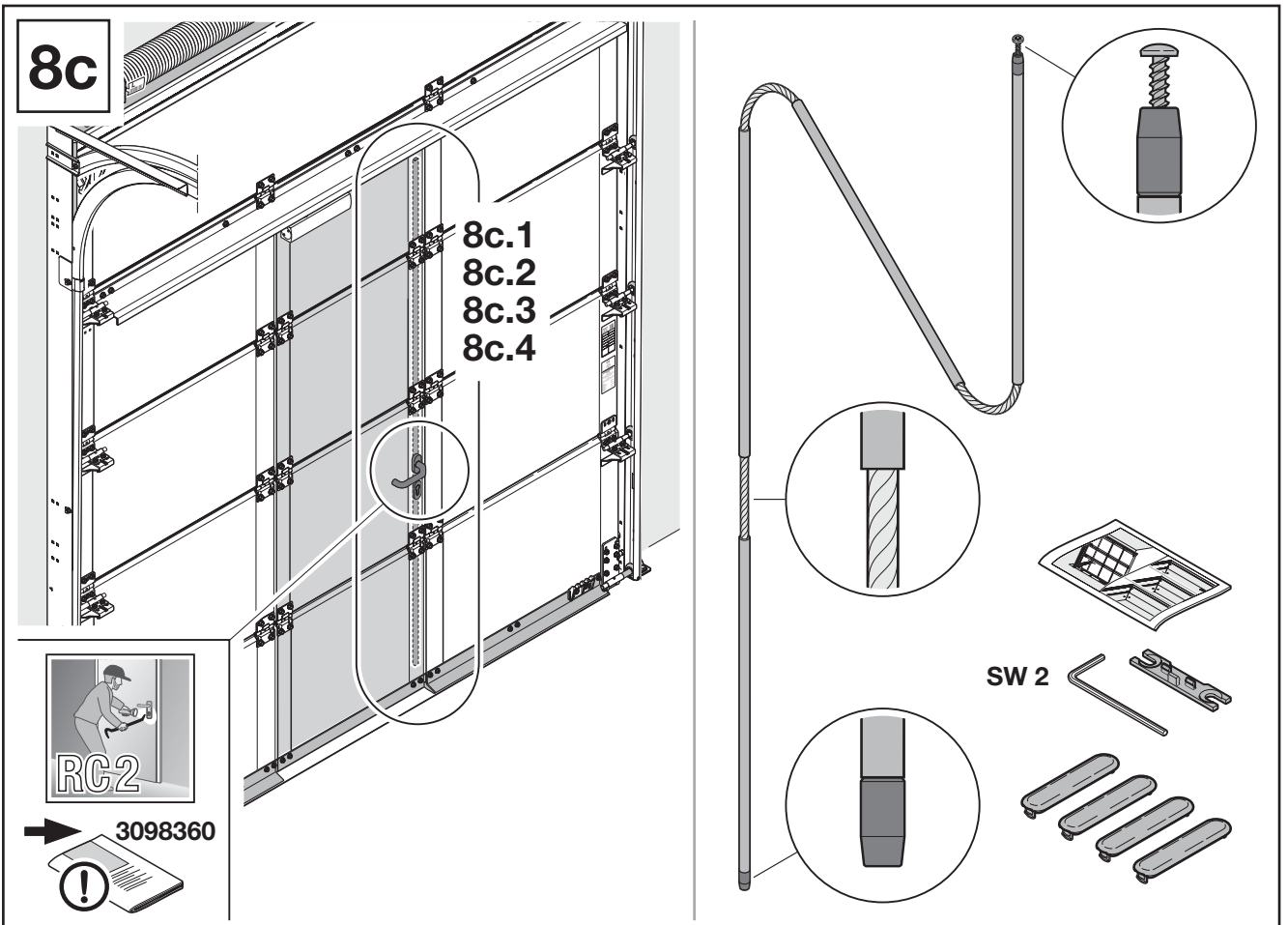

8c.2

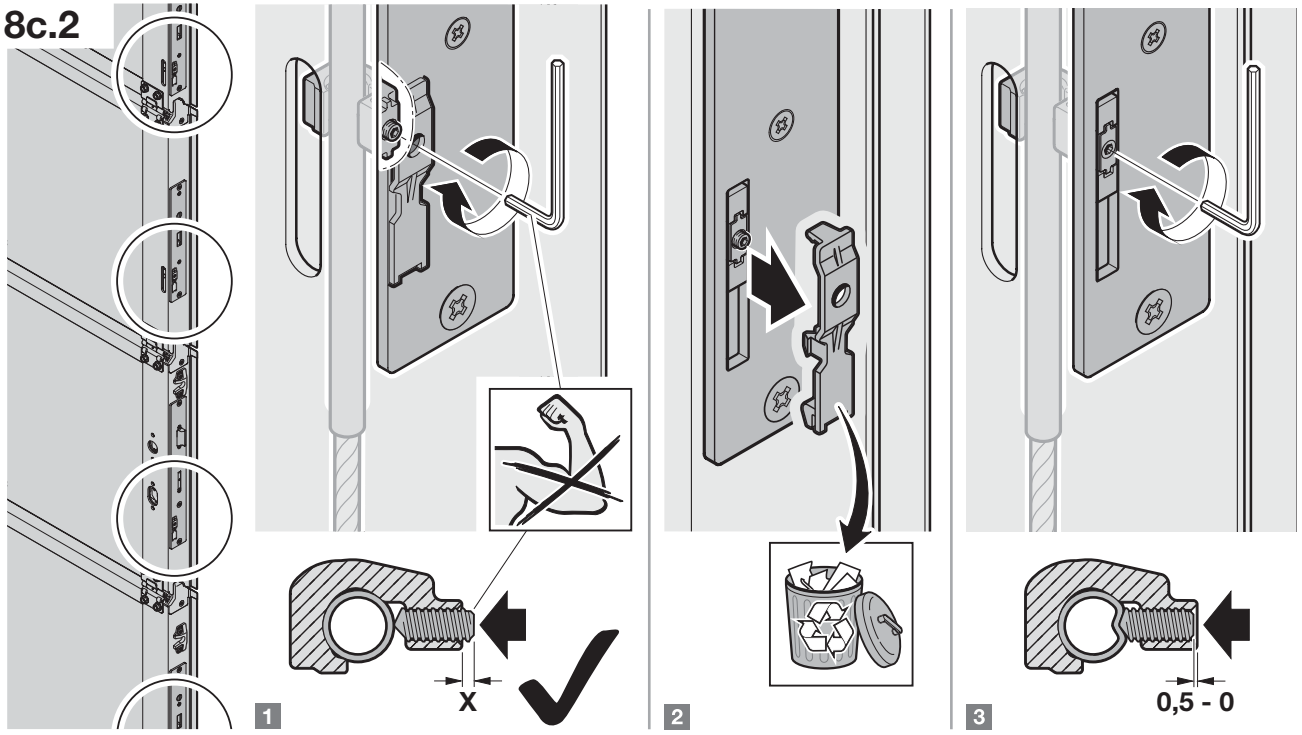

8c.3

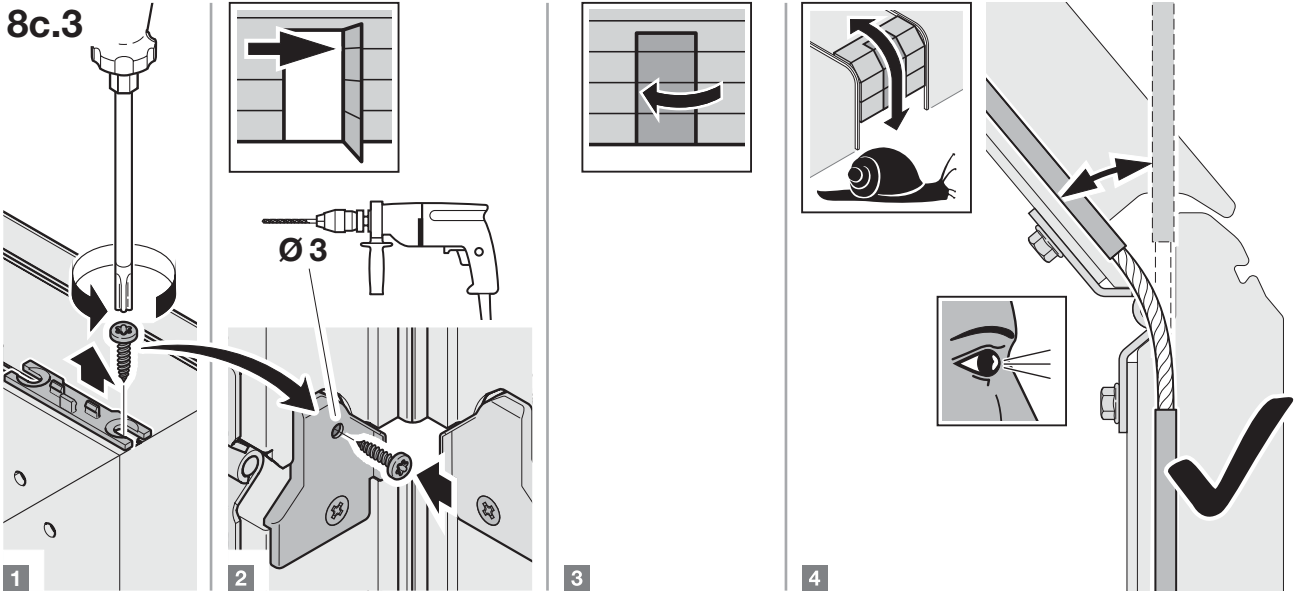

8c.4

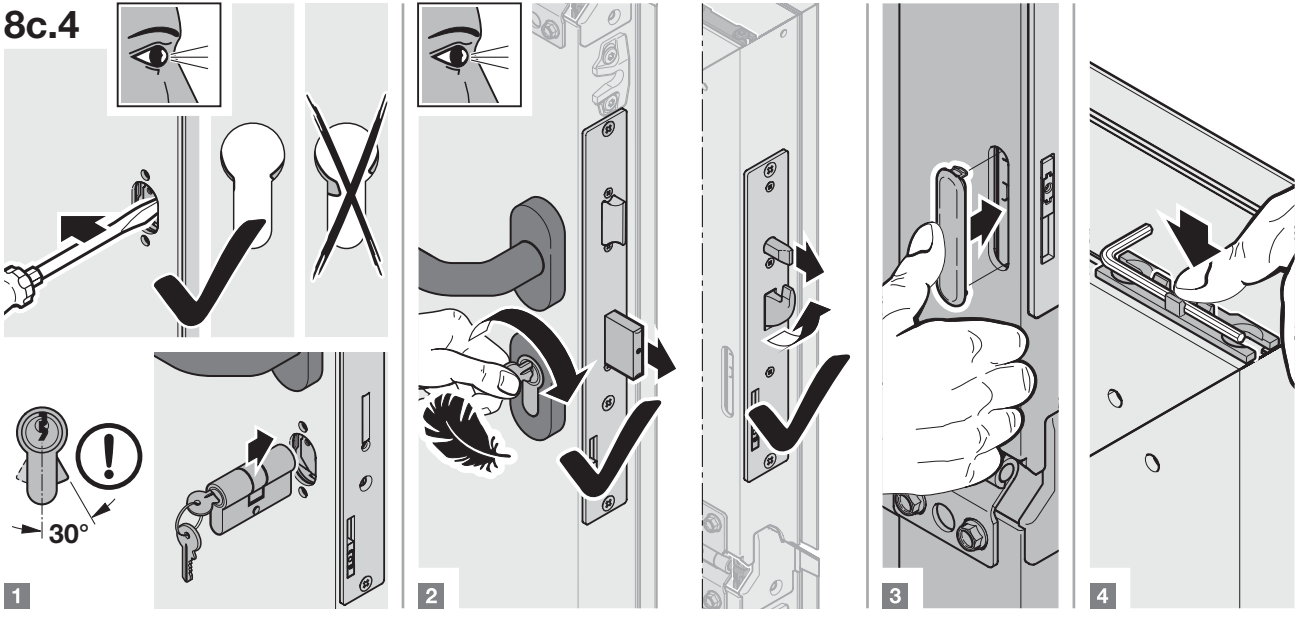

9

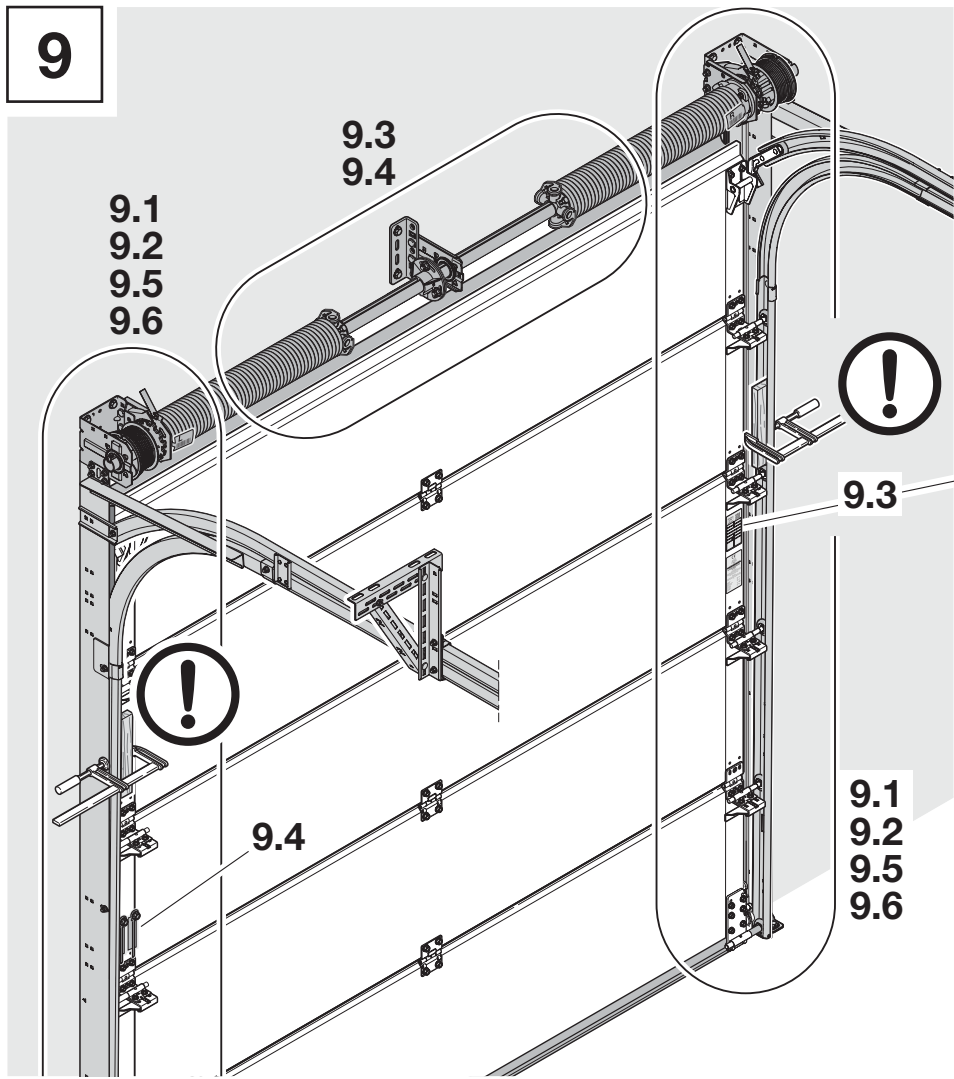

**BlueControl**  
  
**HÖRMANN**

Auftrags Nr. Order no.	Tor Nr. Door no.
Produkt Nr. Product no.	Baujahr Year of manufacture
Toratyp Door type	
Breite x Höhe Width x height <b>LZ x RM</b>	
Beschlag Track application	Höherführung High-lift
Federspannung No. of spring turns <b>X</b>	Gewicht Weight
Feder links Spring left	Feder rechts Spring right

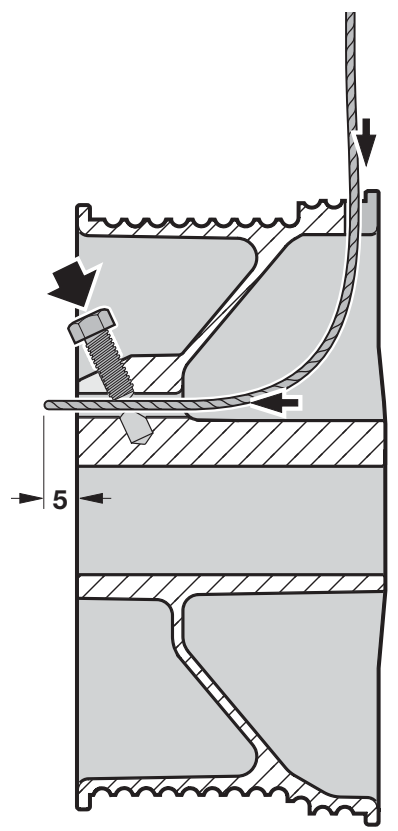
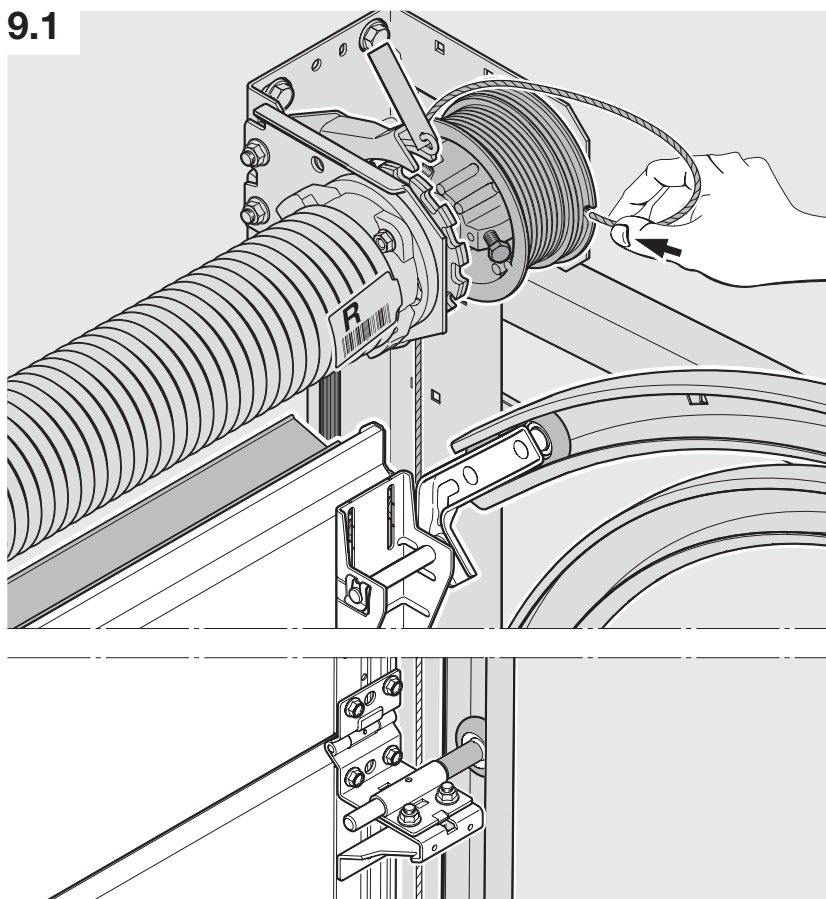

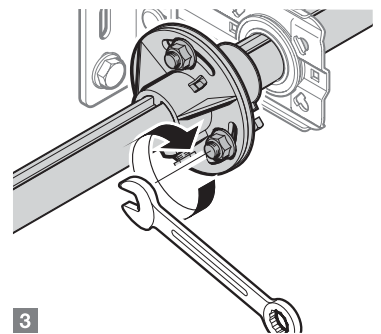
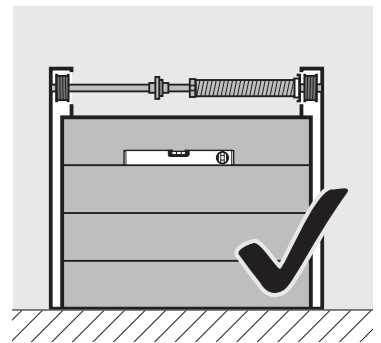
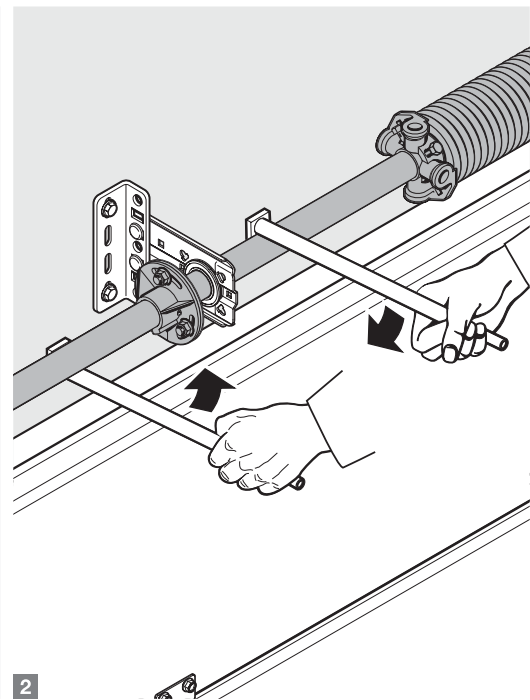
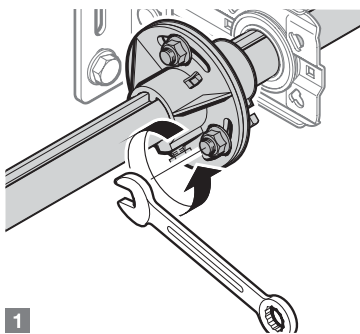
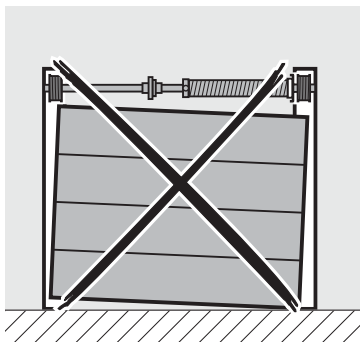
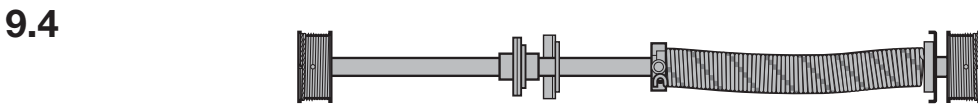
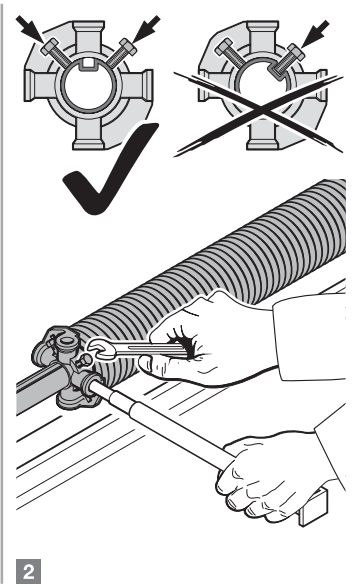
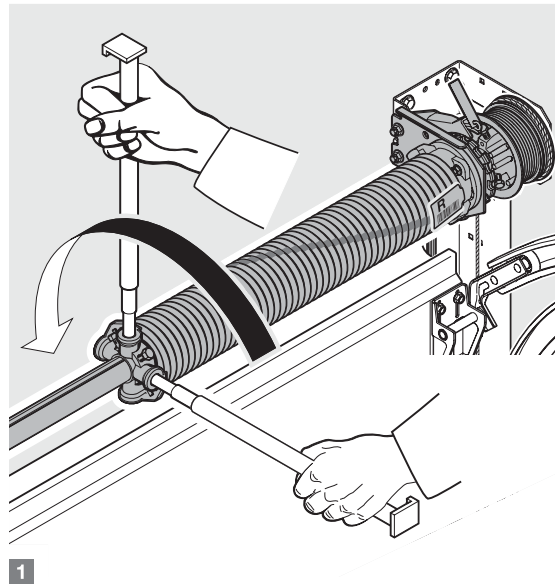
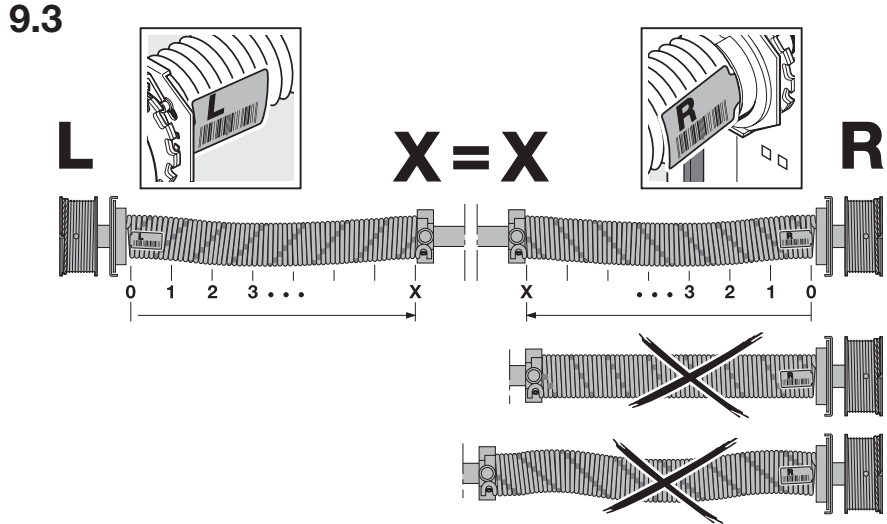
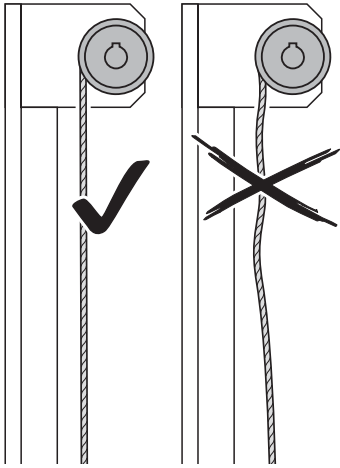
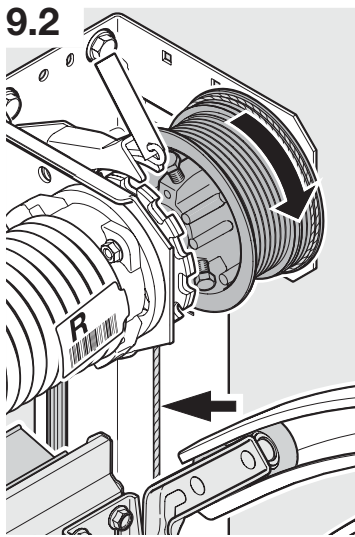

9.5

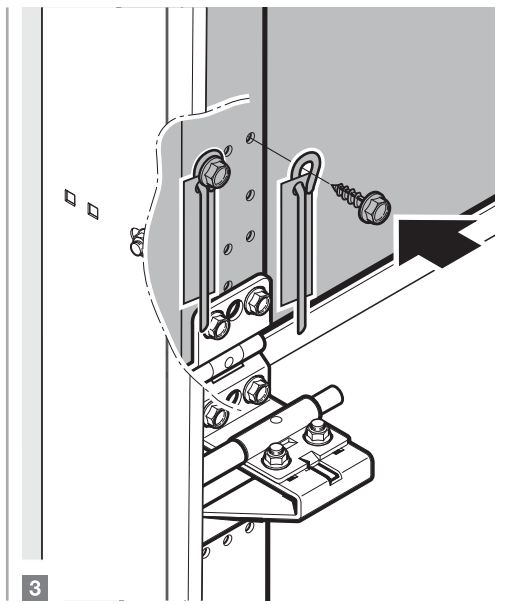
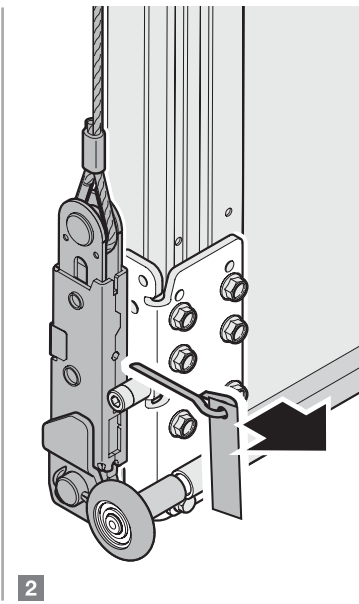
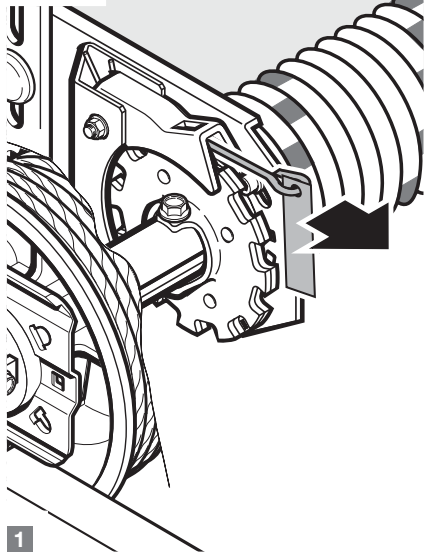

9.6

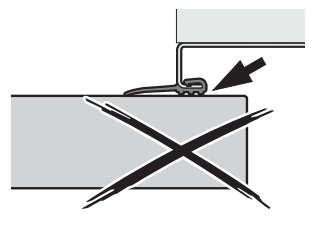
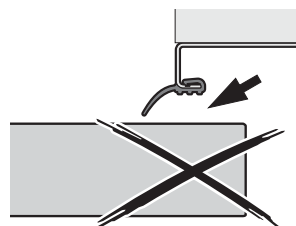
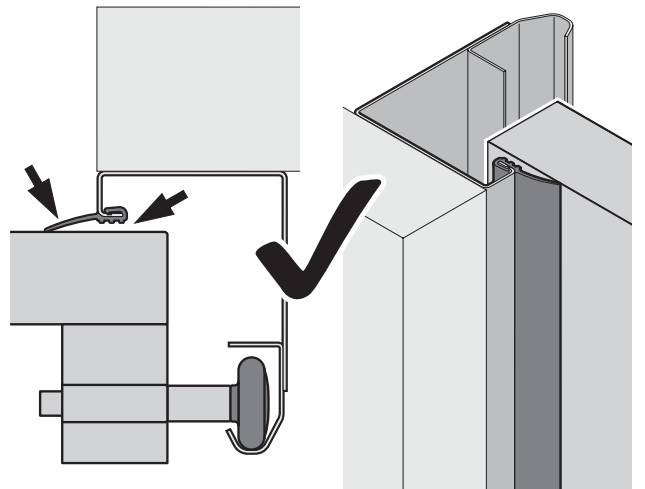
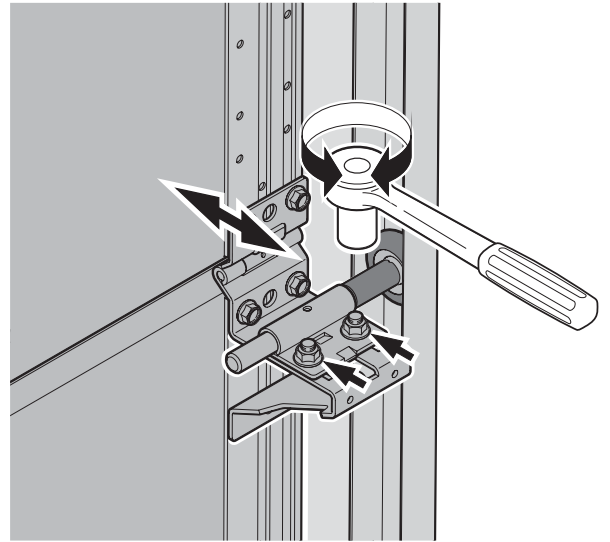
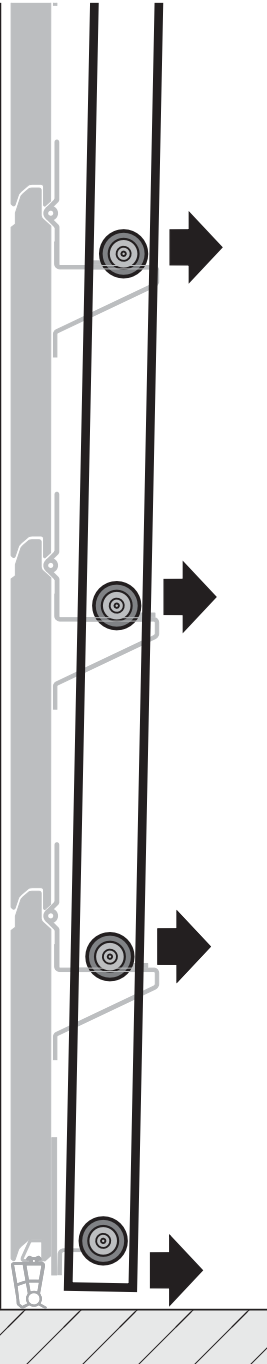
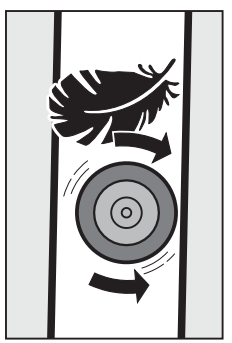
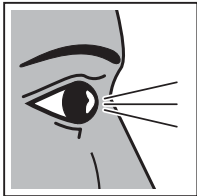

10

10.1

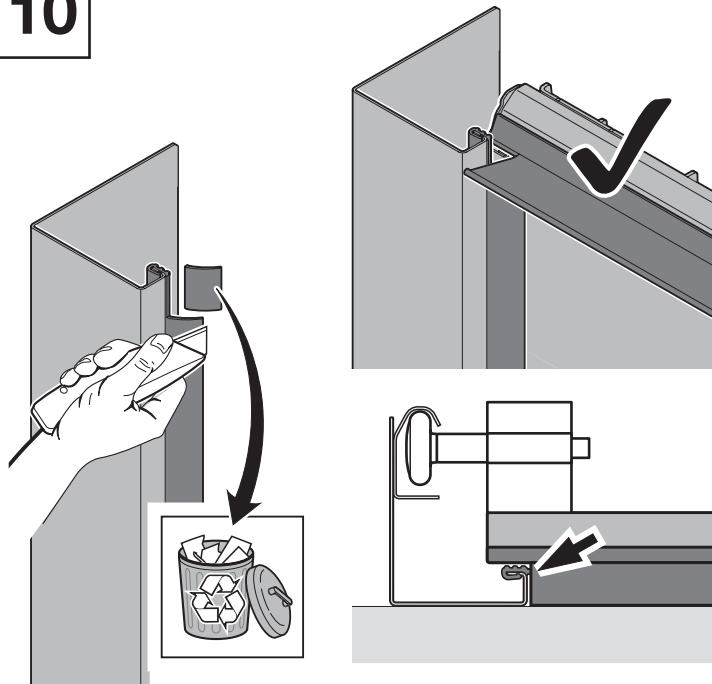

10.2

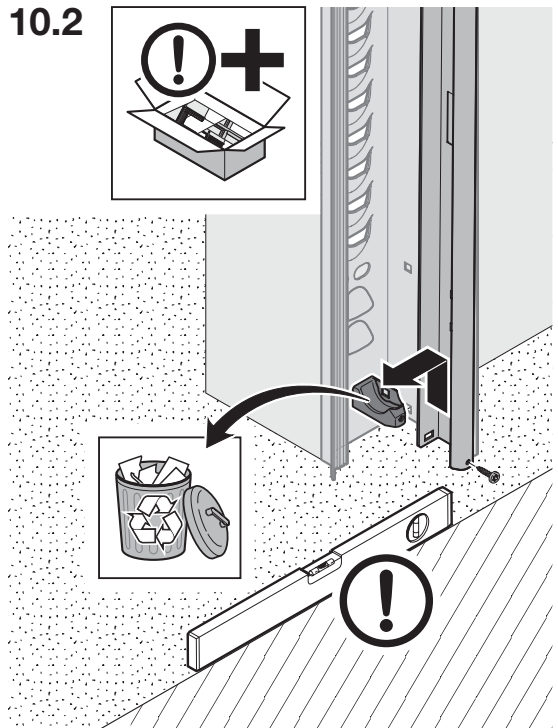

11

