

DE Anleitung für Montage, Betrieb, Wartung und Demontage

Sektionaltore für Industrie Baureihe 60, Bautiefe 42 / 67 mm

EN Instructions for Fitting, Operating, Maintenance and Dismantling

Series 60 Industrial Sectional Doors, depth 42 / 67 mm

FR Notice de montage, d'utilisation, d'entretien et de démontage

Porte sectionnelle industrielle série 60, épaisseur 42 / 67 mm

ES Instrucciones para el montaje, funcionamiento, mantenimiento y desmontaje

Puertas seccionales industriales Serie 60, profundidad 42 / 67 mm

RU Руководство по монтажу, эксплуатации, техобслуживанию и демонтажу

Секционные ворота для гаража строительной серии 60, строительная глубина 42 / 67 мм

+

NL	PL	SL	FI	TR	LV	EL
IT	HU	NO	DA	LT	HR	RO
PT	CS	SV	SK	ET	SR	BG

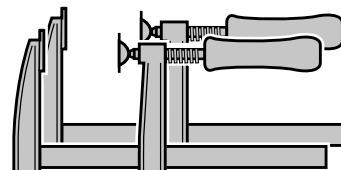
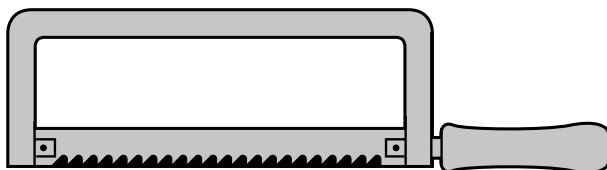
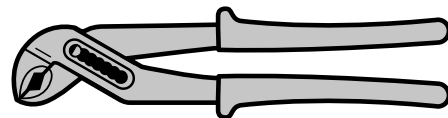
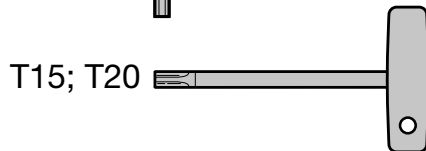
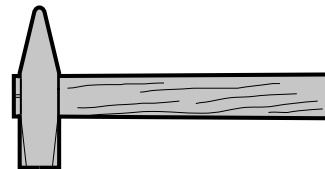
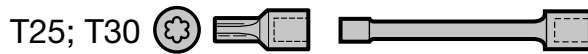
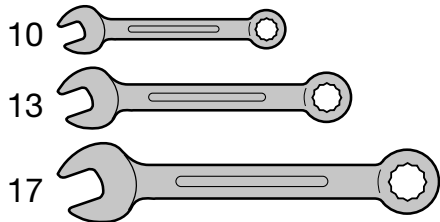
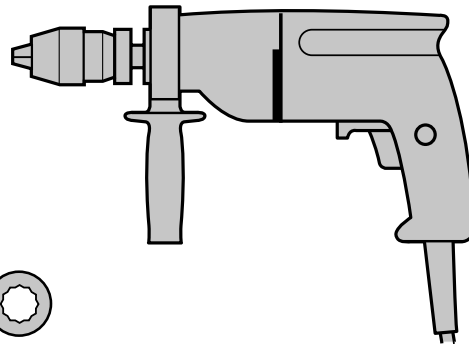
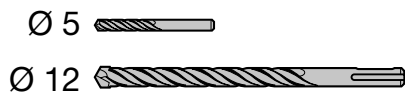
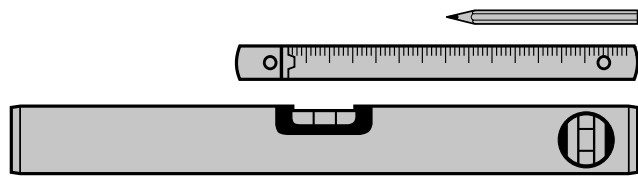
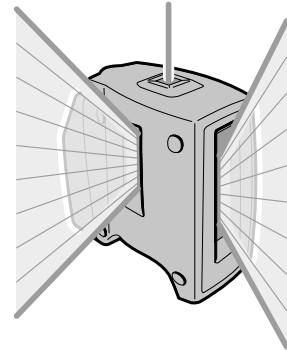
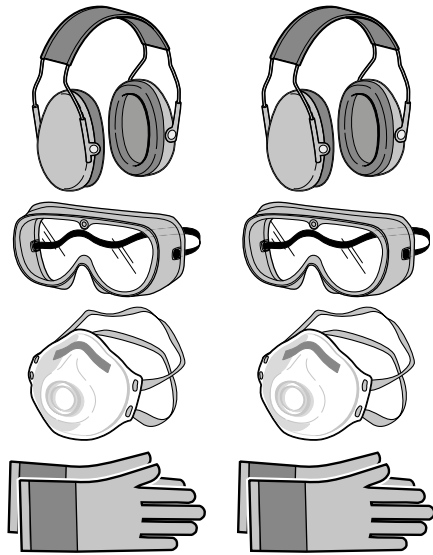
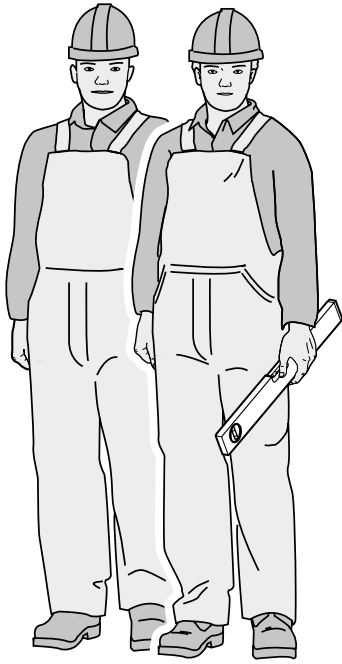

1

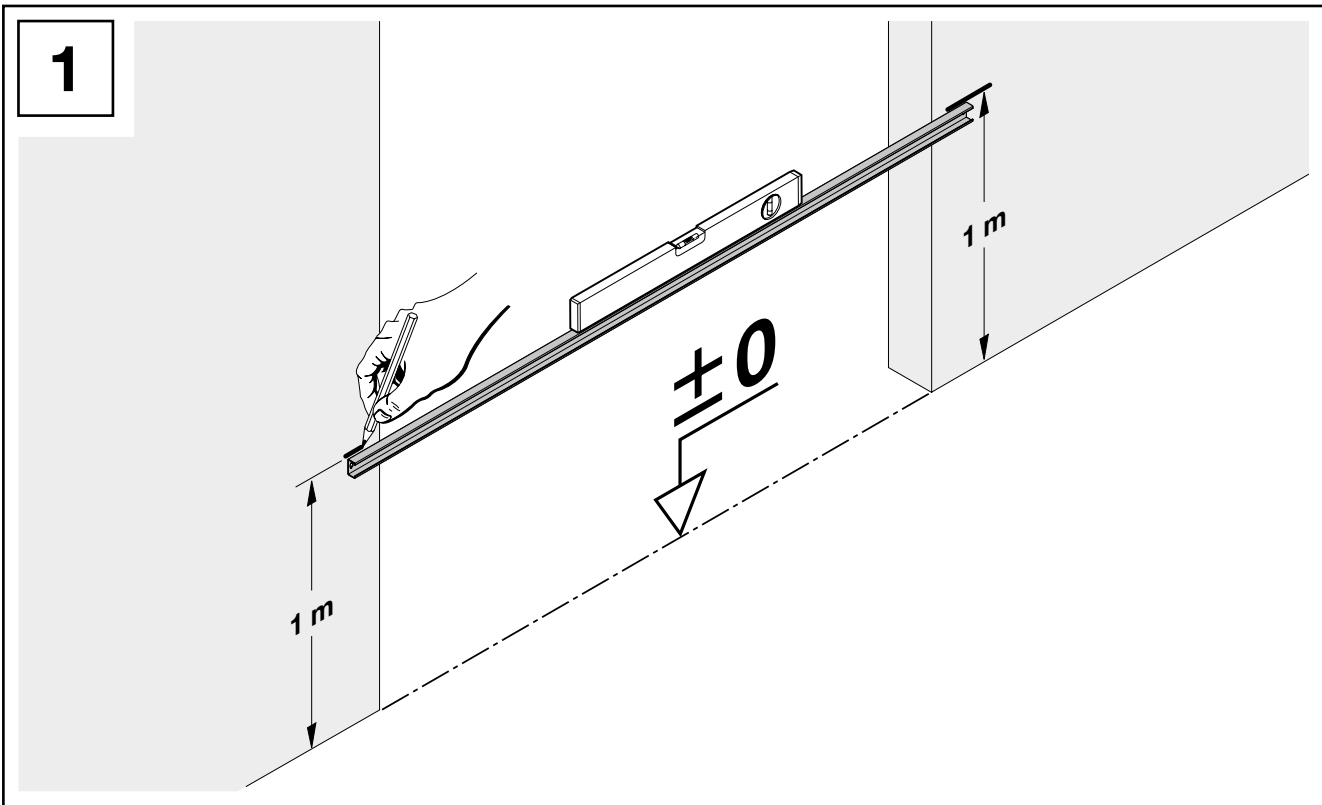

2

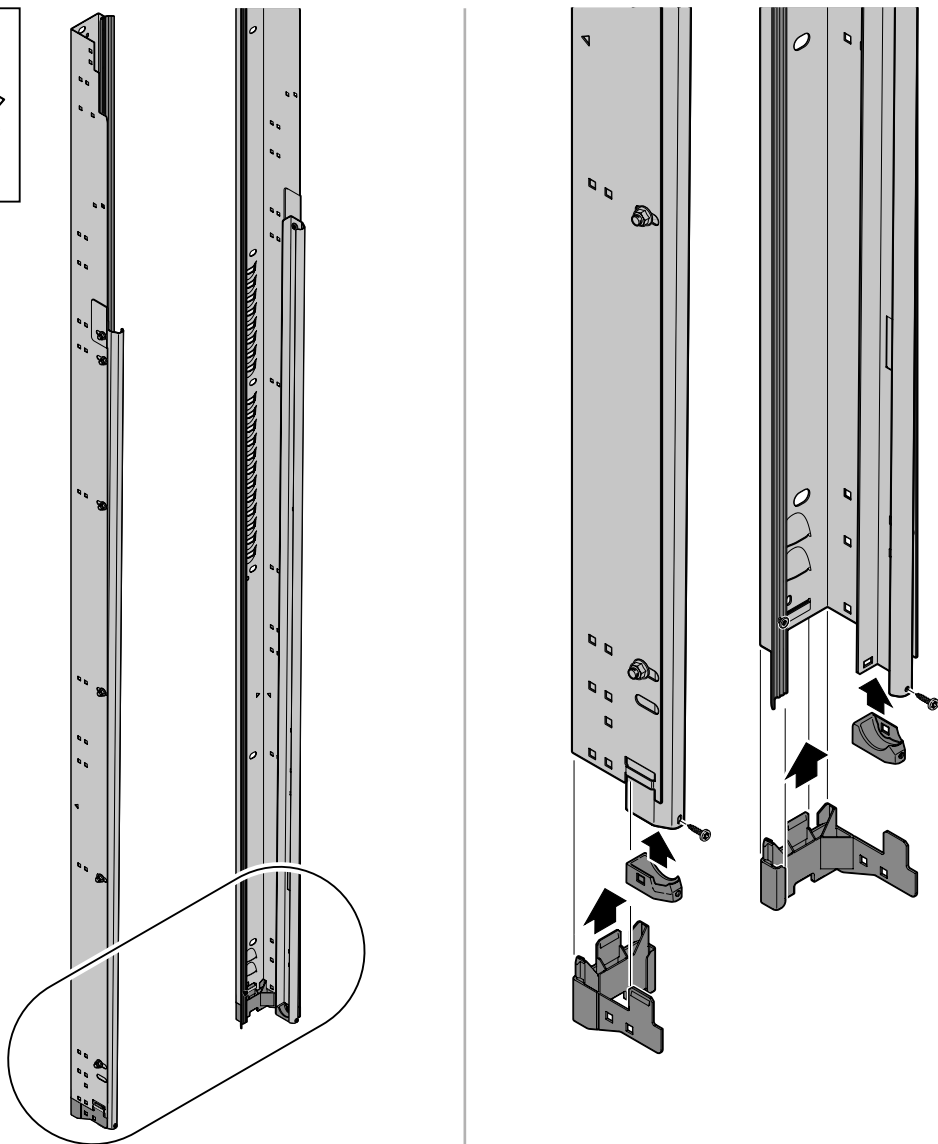
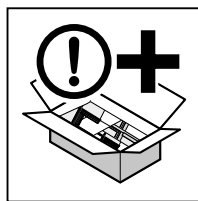

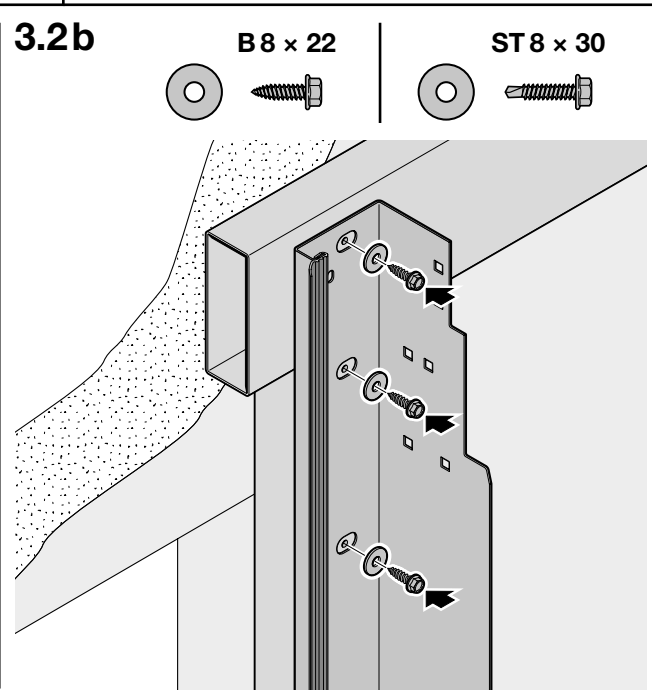
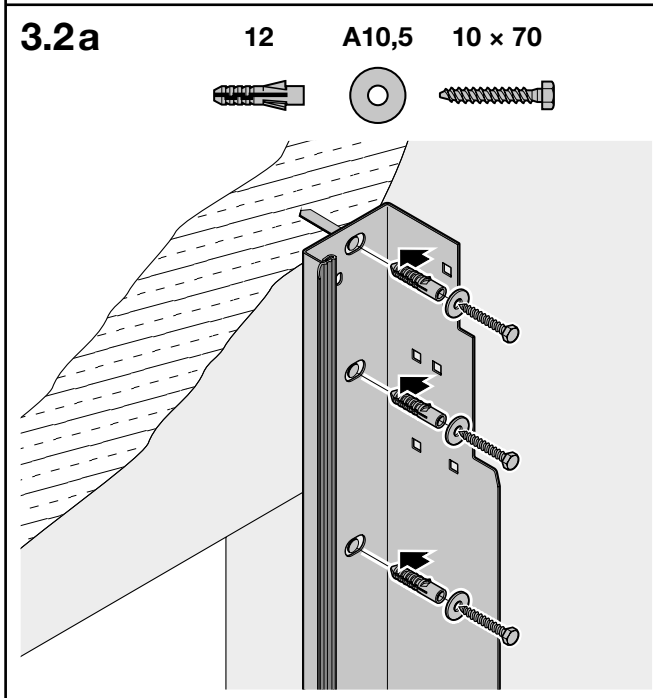
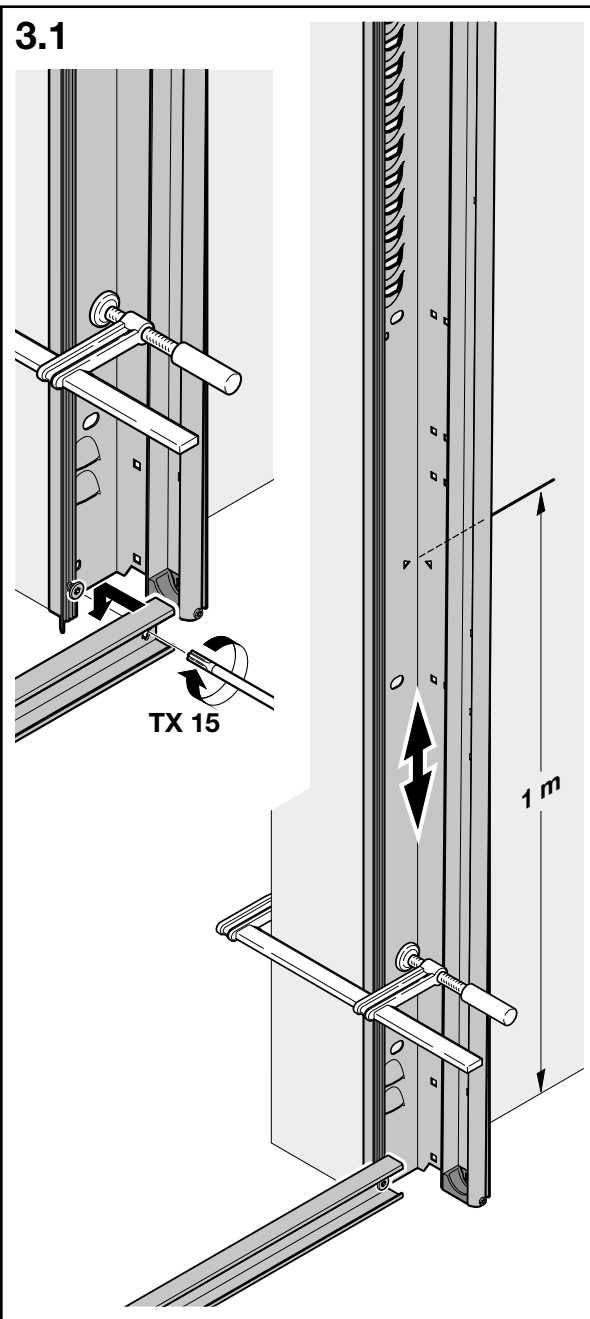
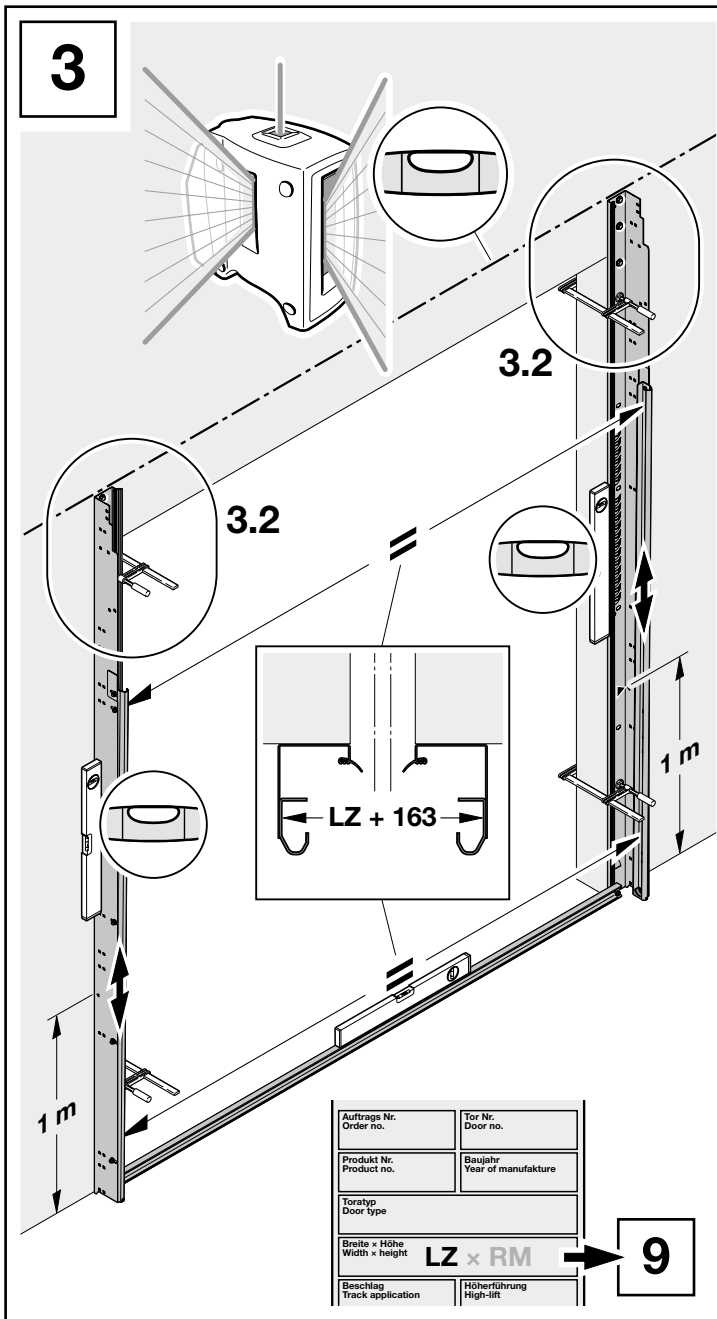

3.3

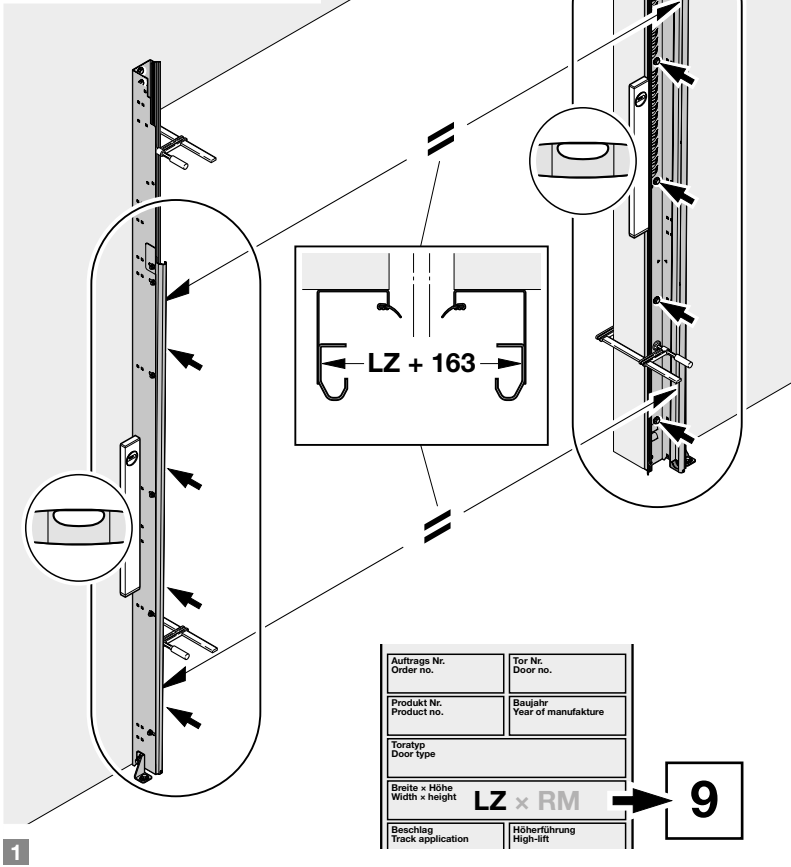

1

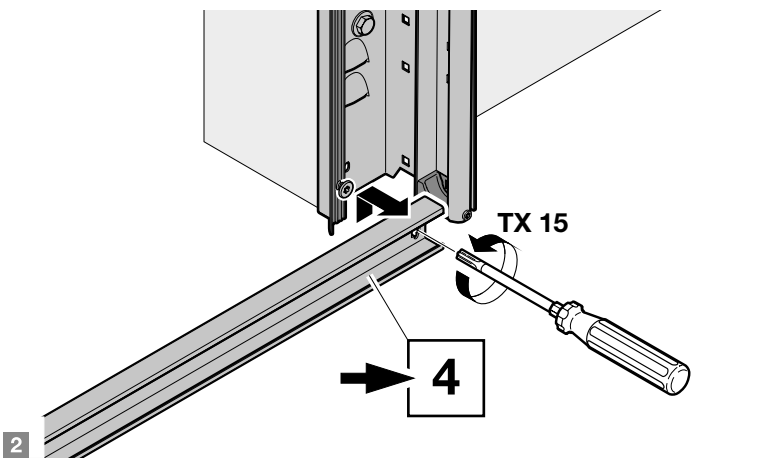
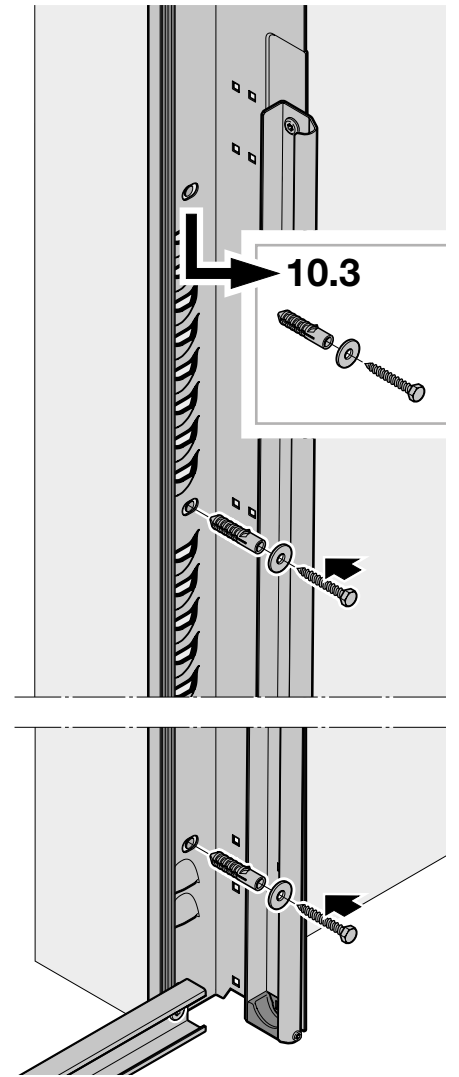

2

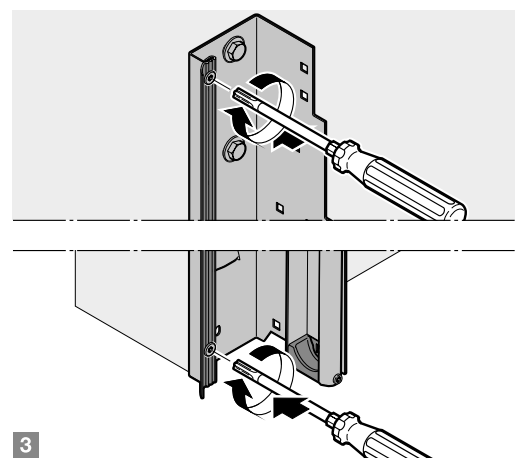

3.4a

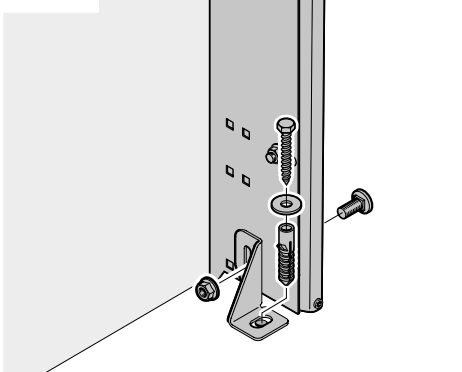

3.4b

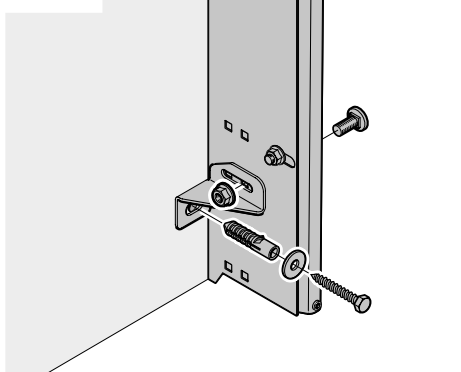

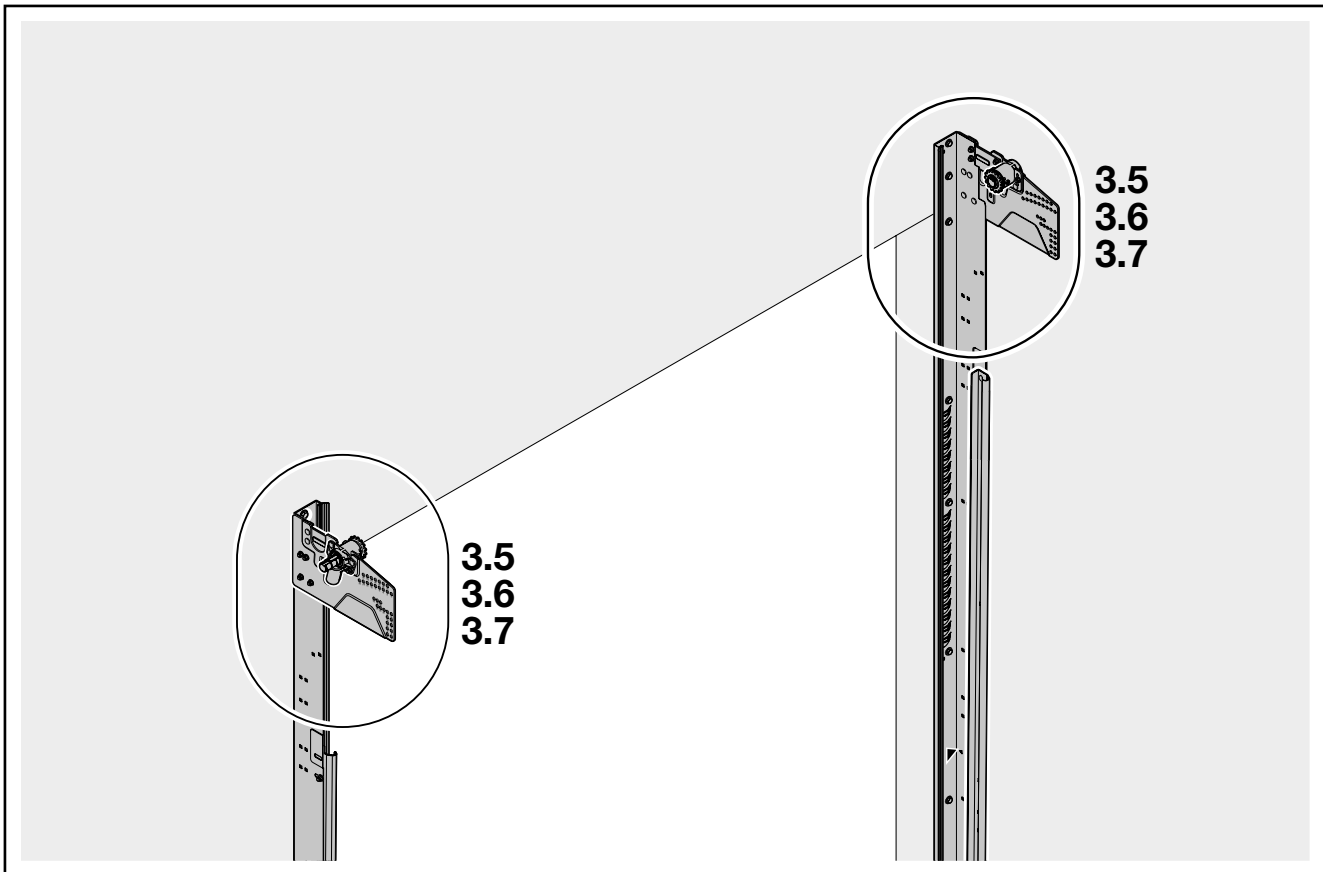

3.5

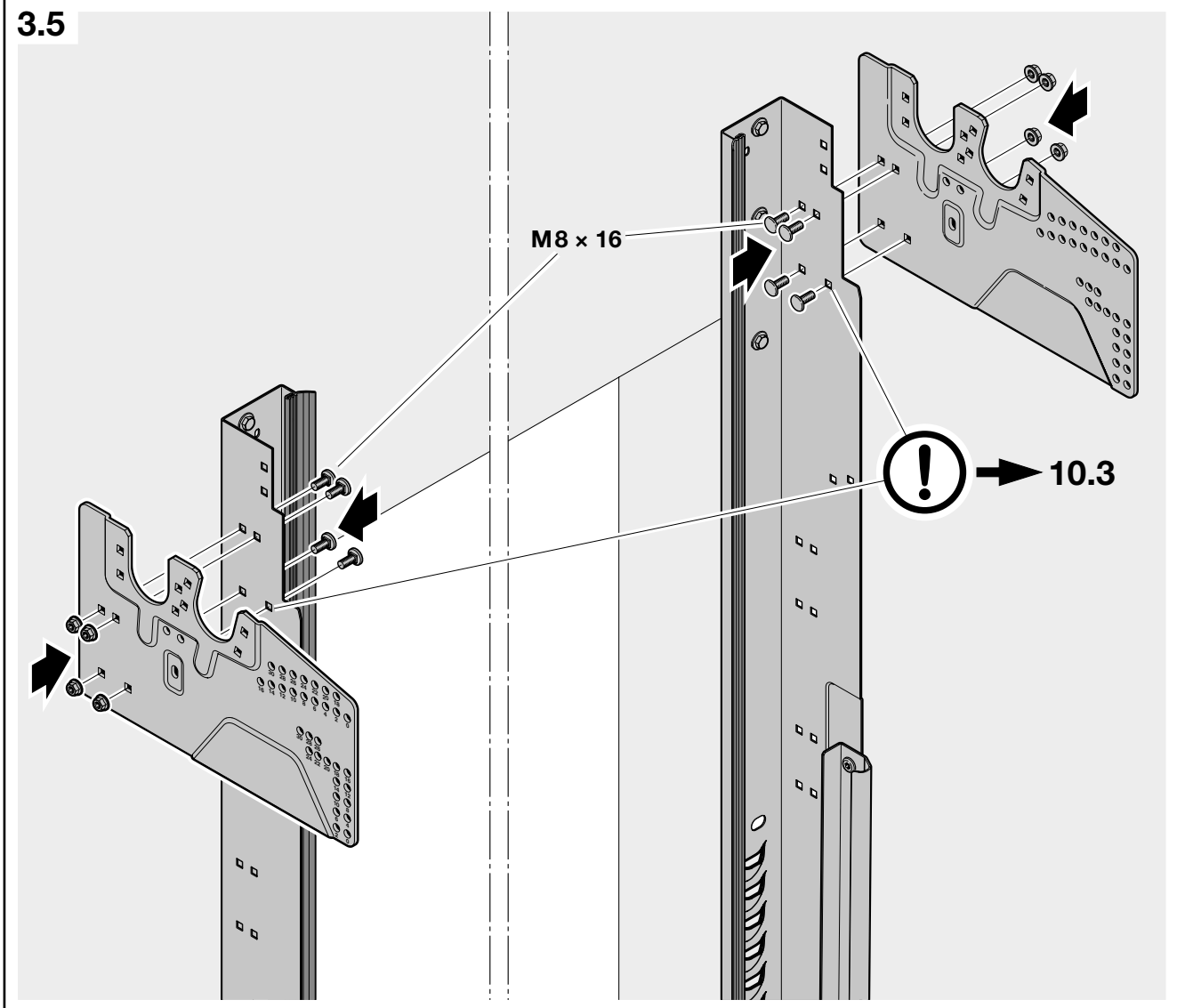

3.6a

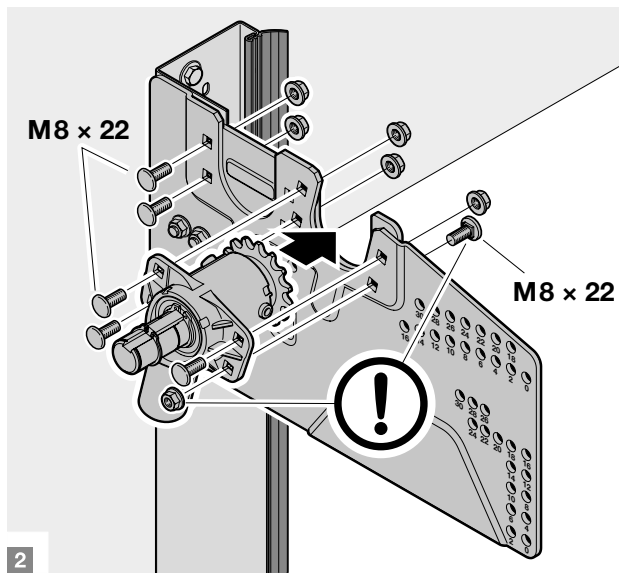
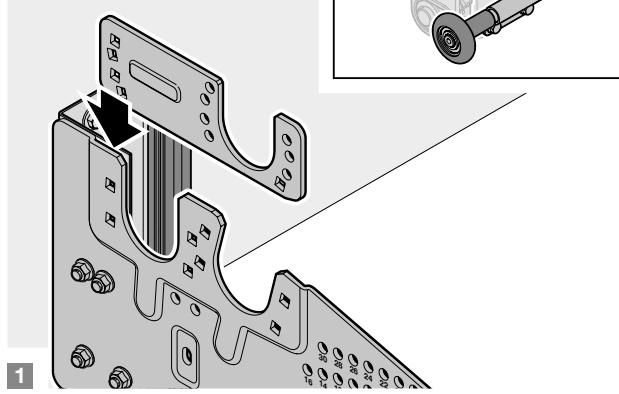
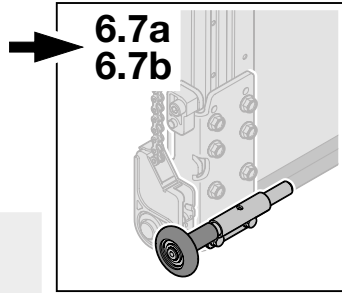

3.6b

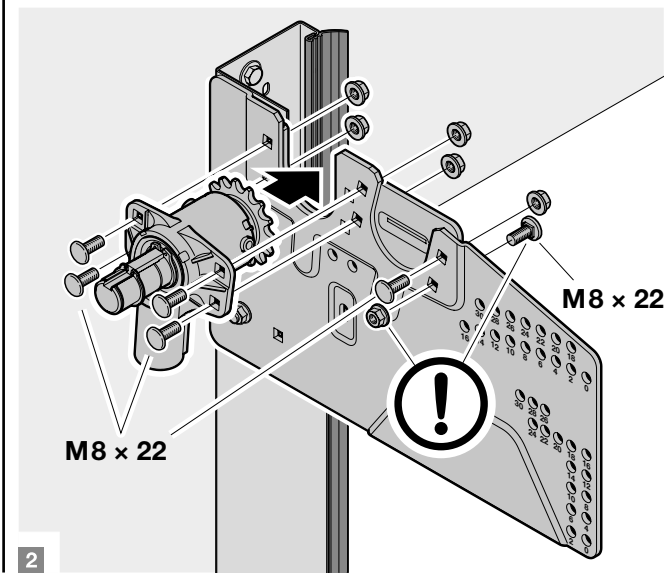
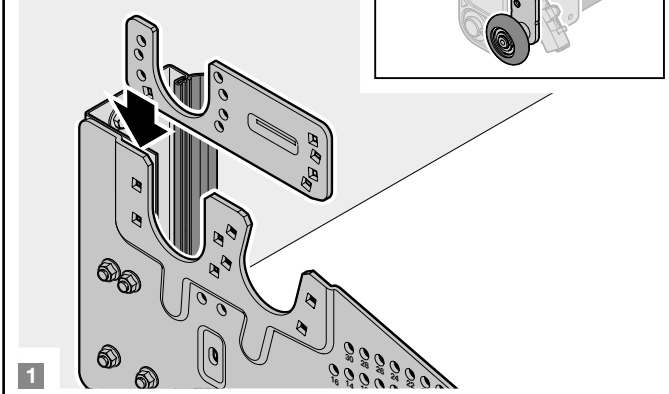
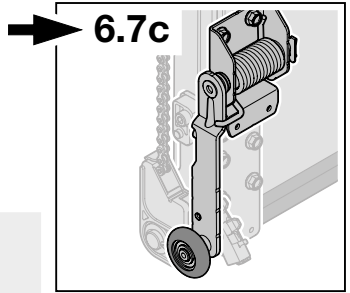
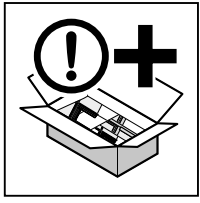

3.7

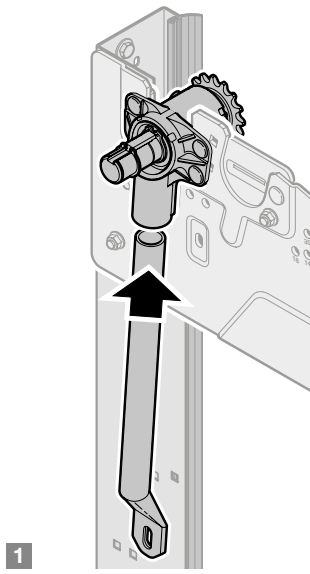
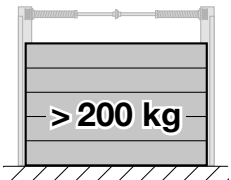

a

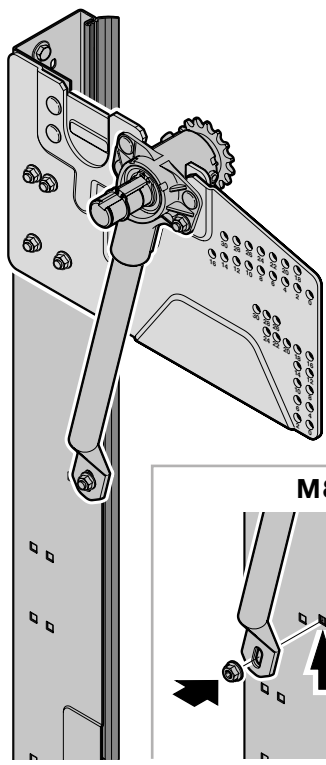

b

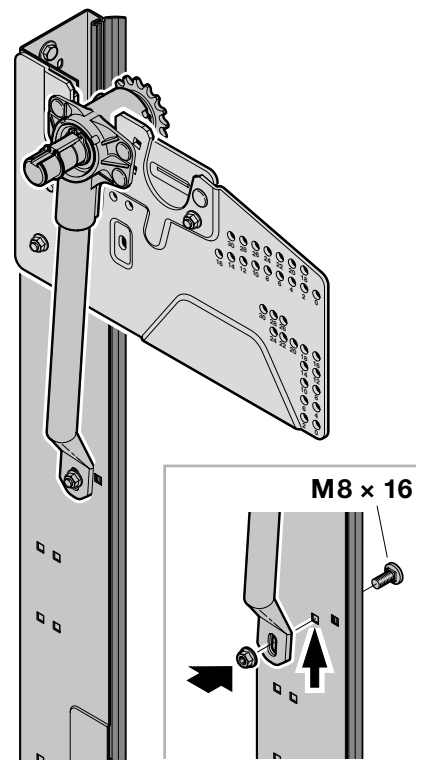

4

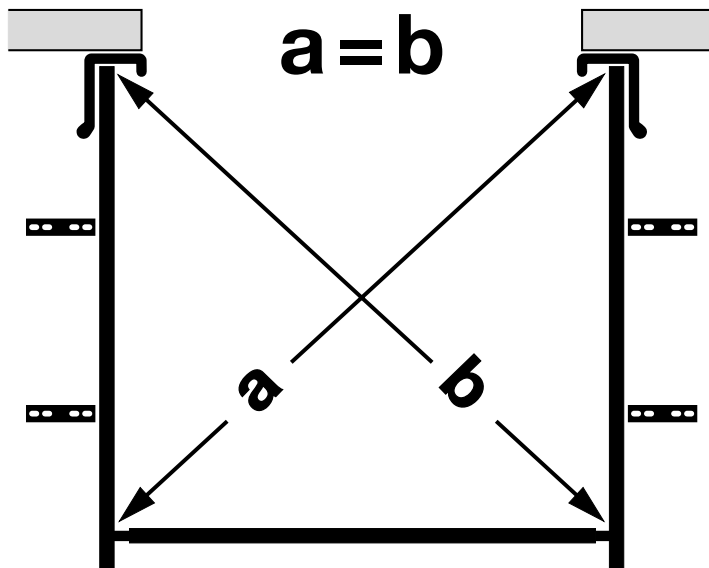
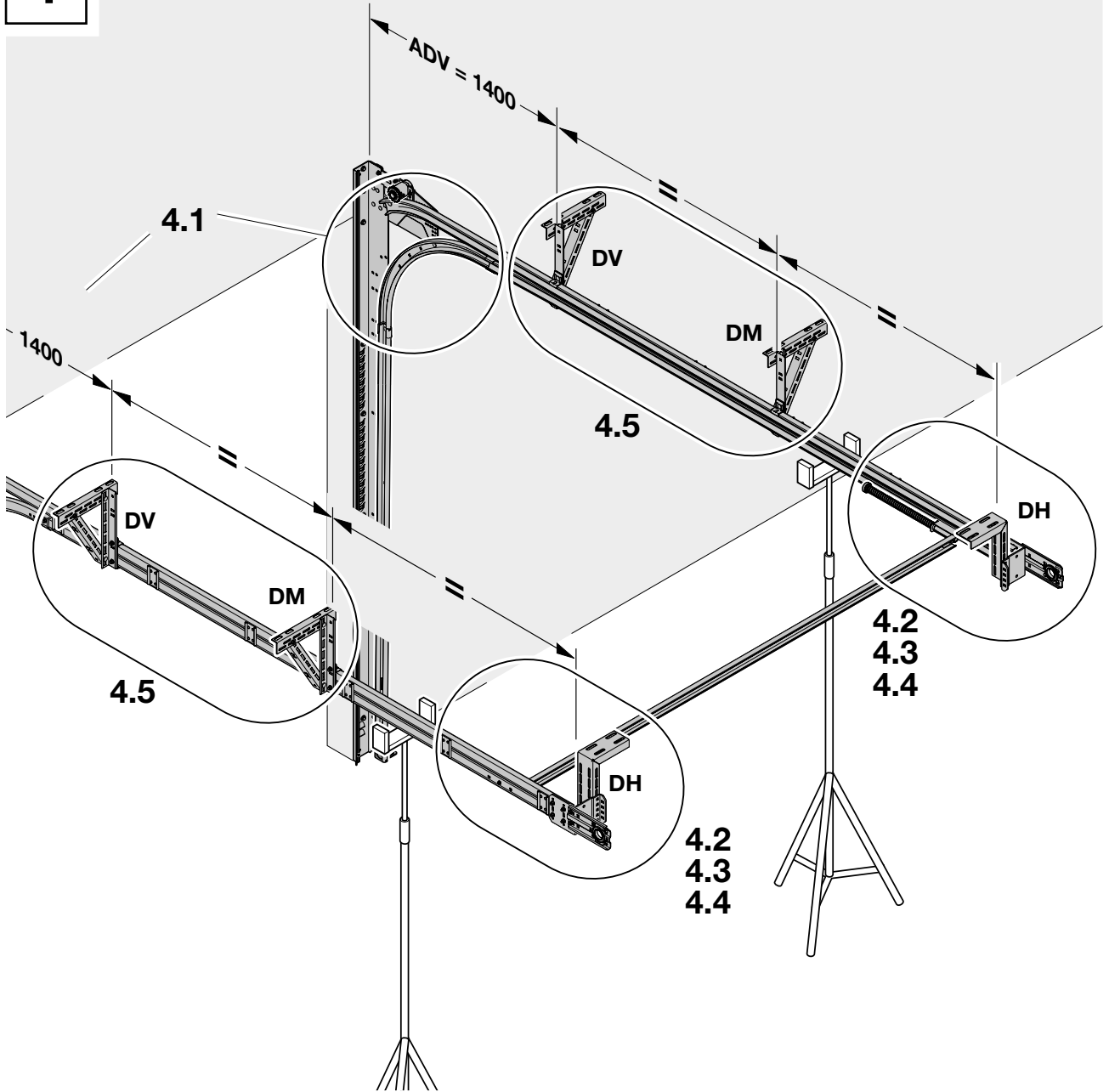

4.1a

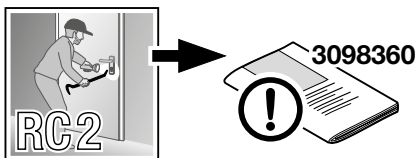
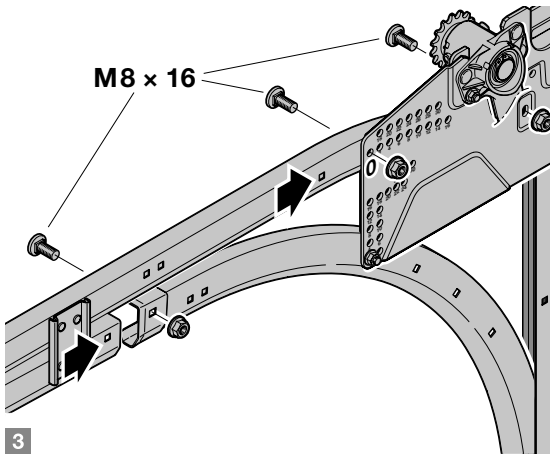
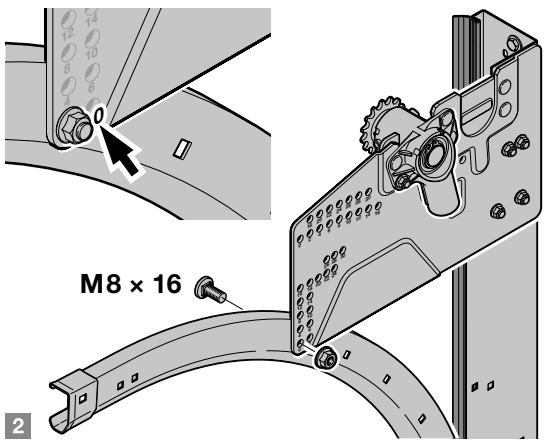
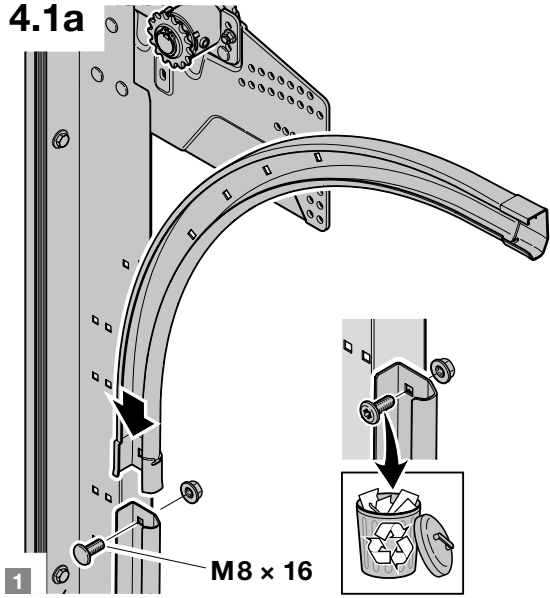

4.1b

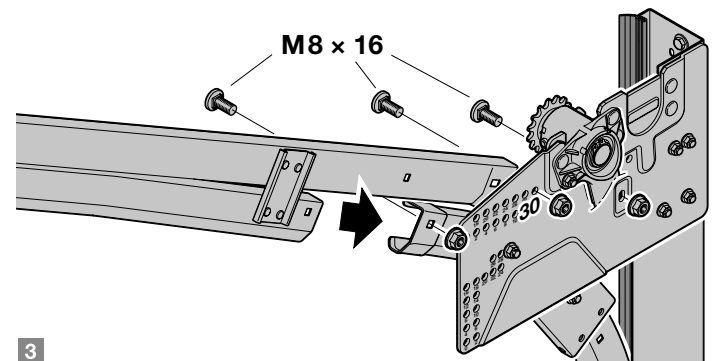
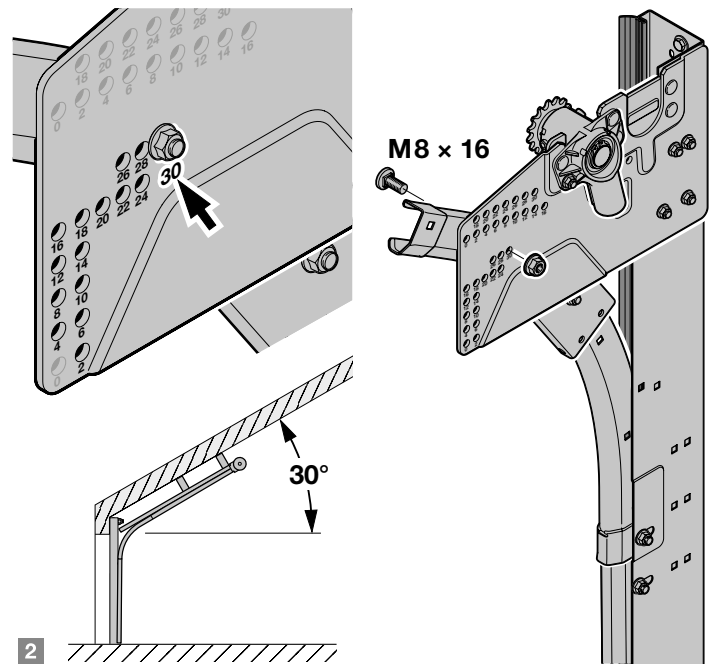
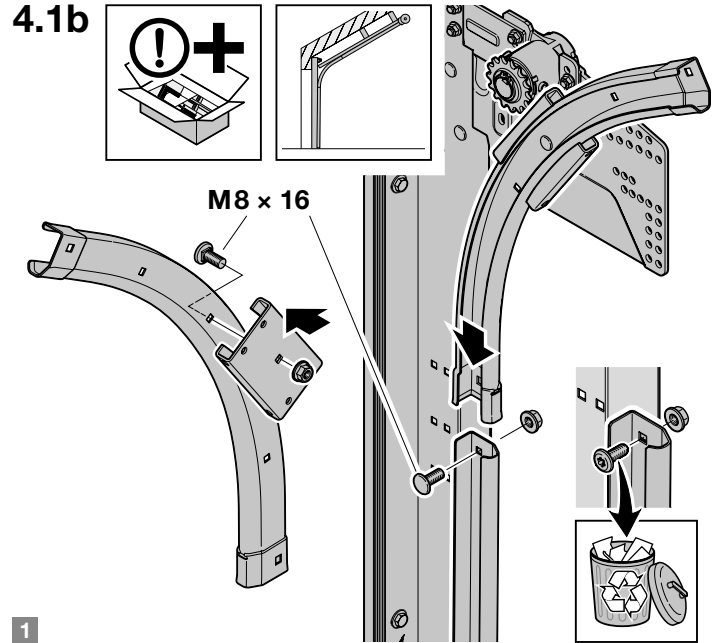

4.1c

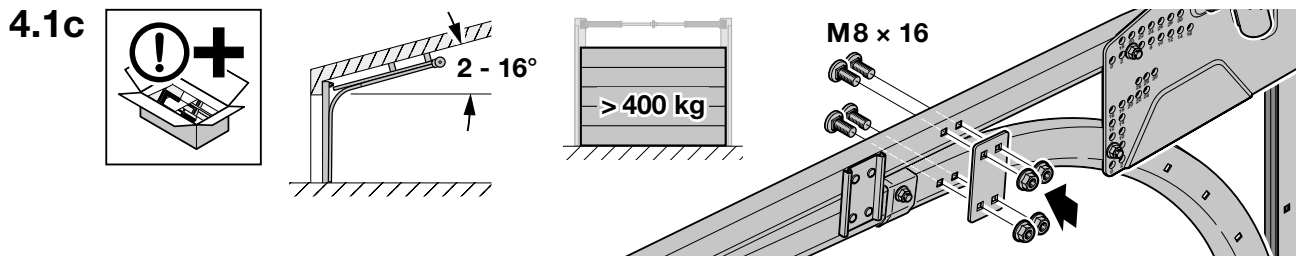

4.2

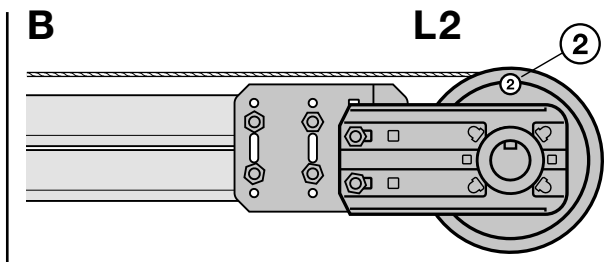
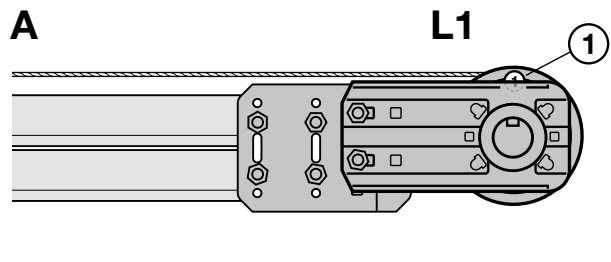
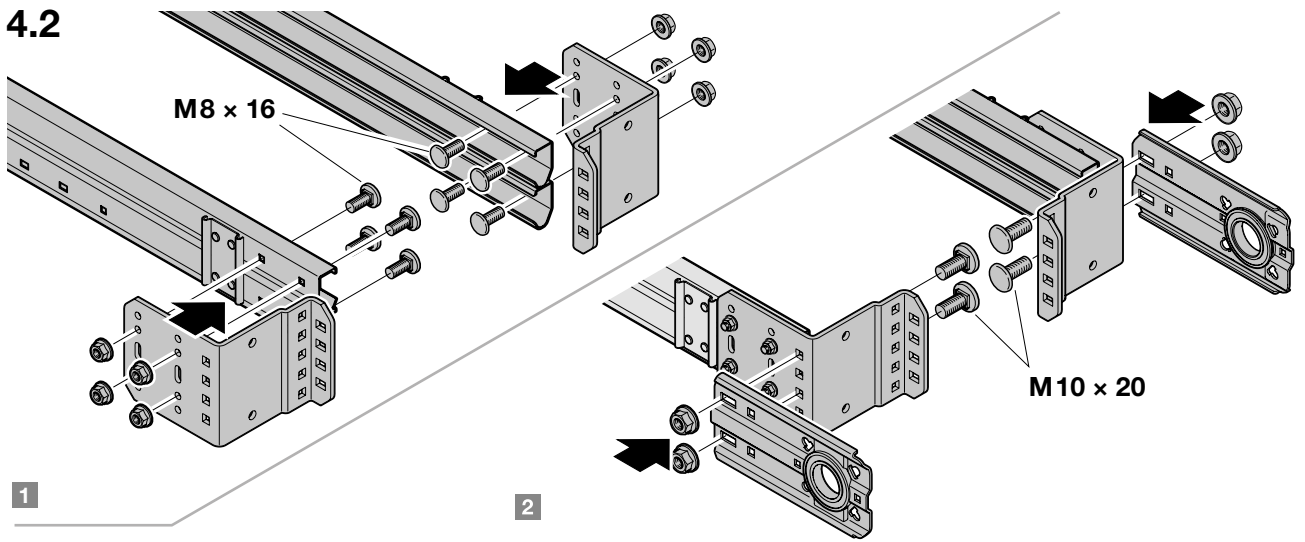

4.3

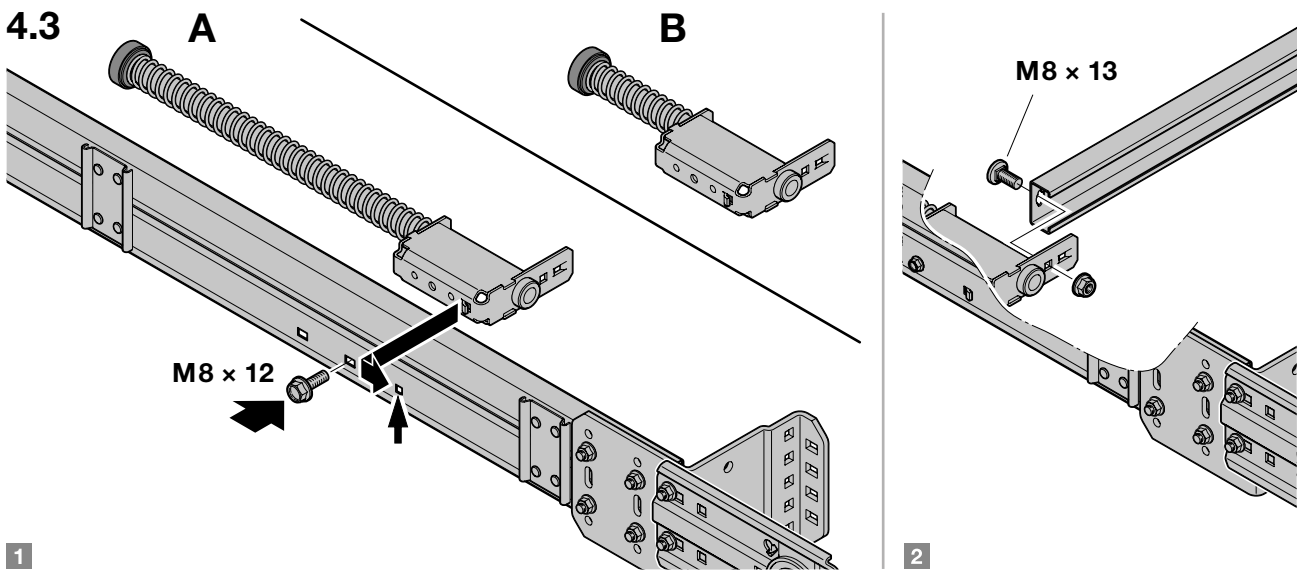

4.4

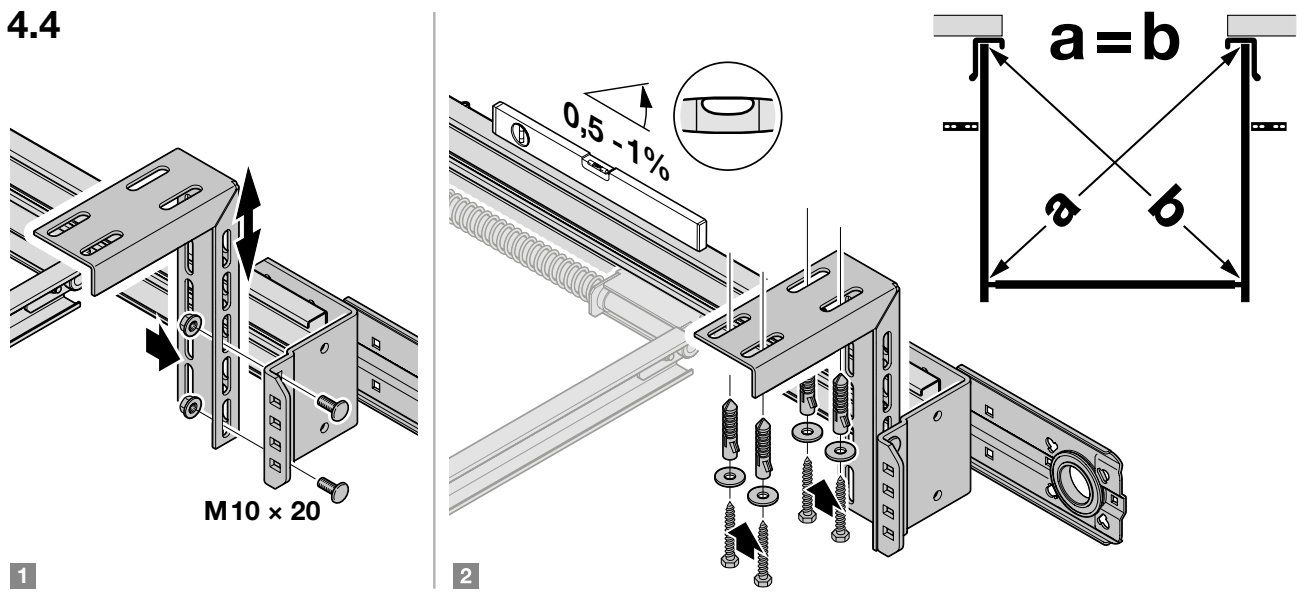

4.5a

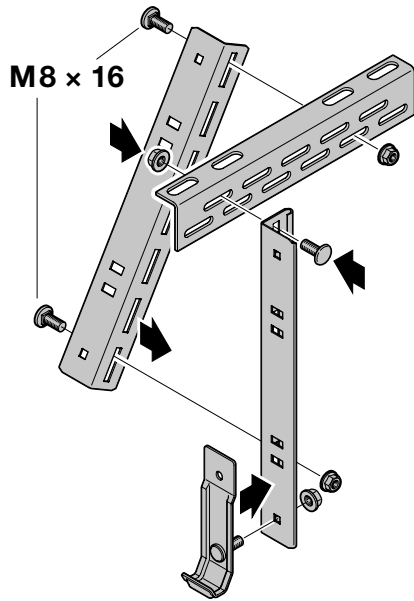

1a

4.5b

< 201	> 1768
201 - 300	> 1405
> 300	> 1041

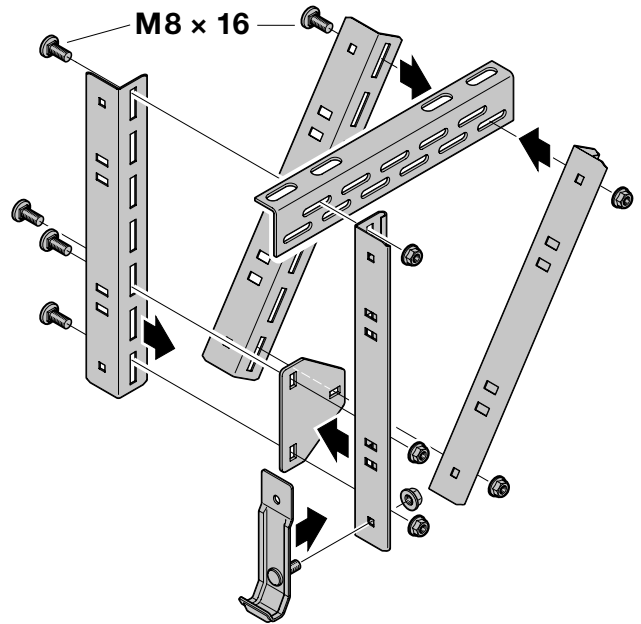

1b

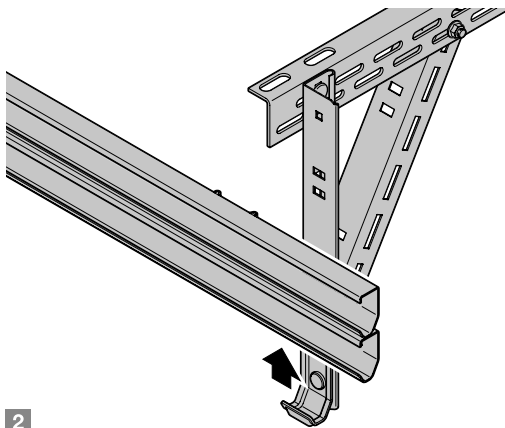

2

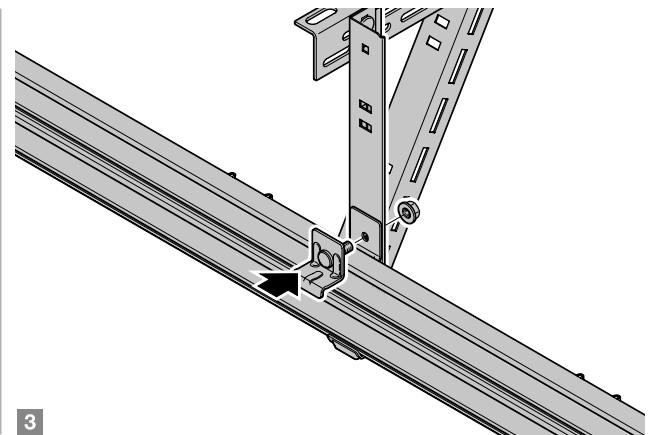

3

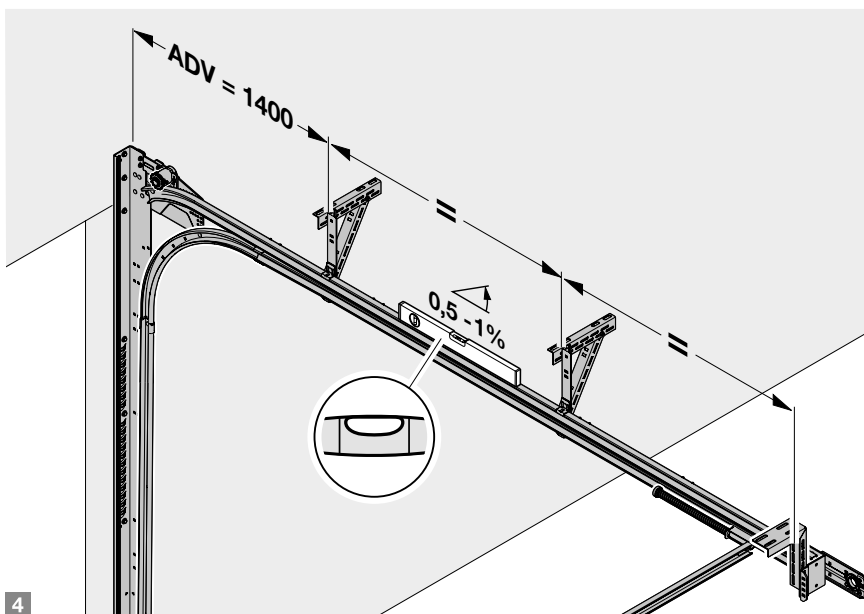

4

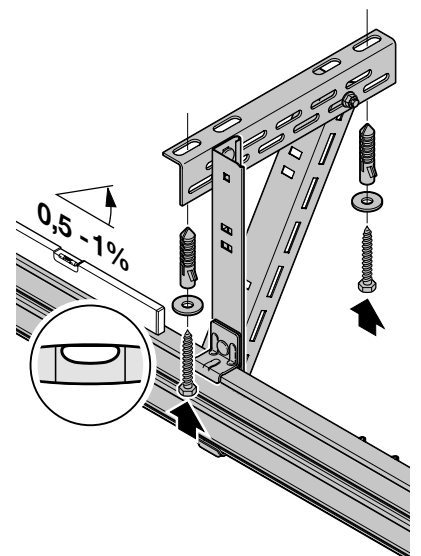

5

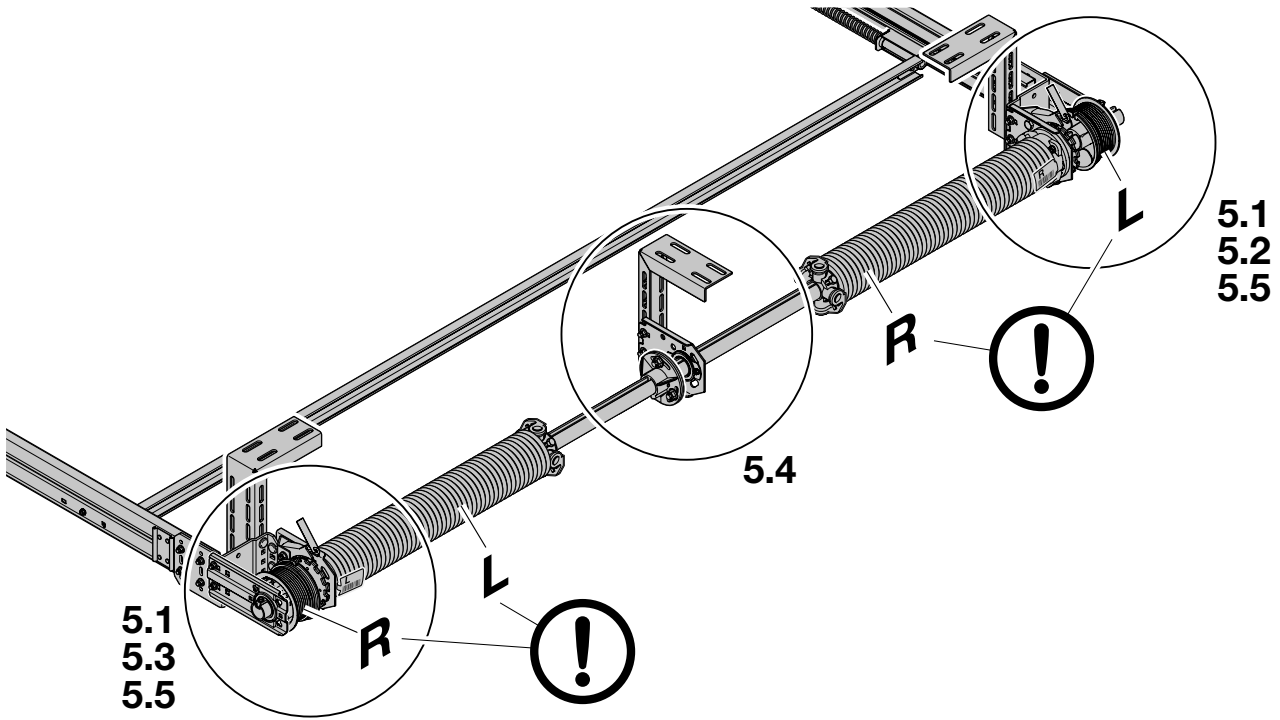
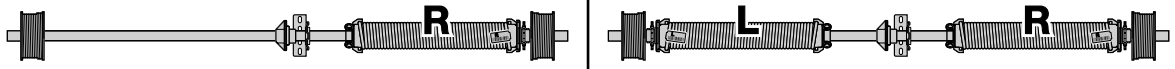

5.1

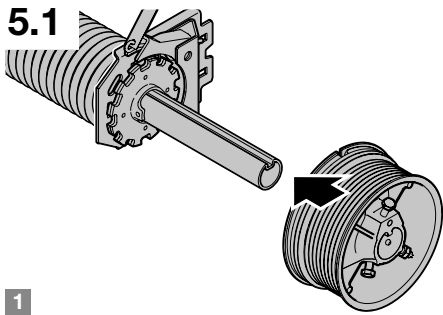

1

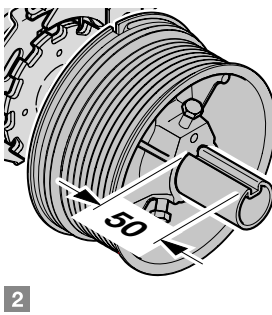

2

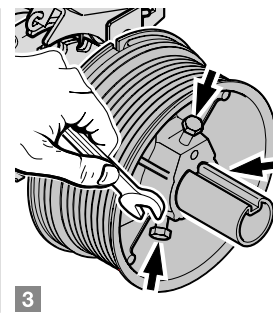

3

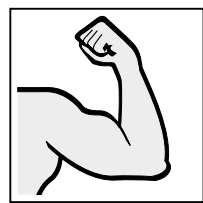

5.2

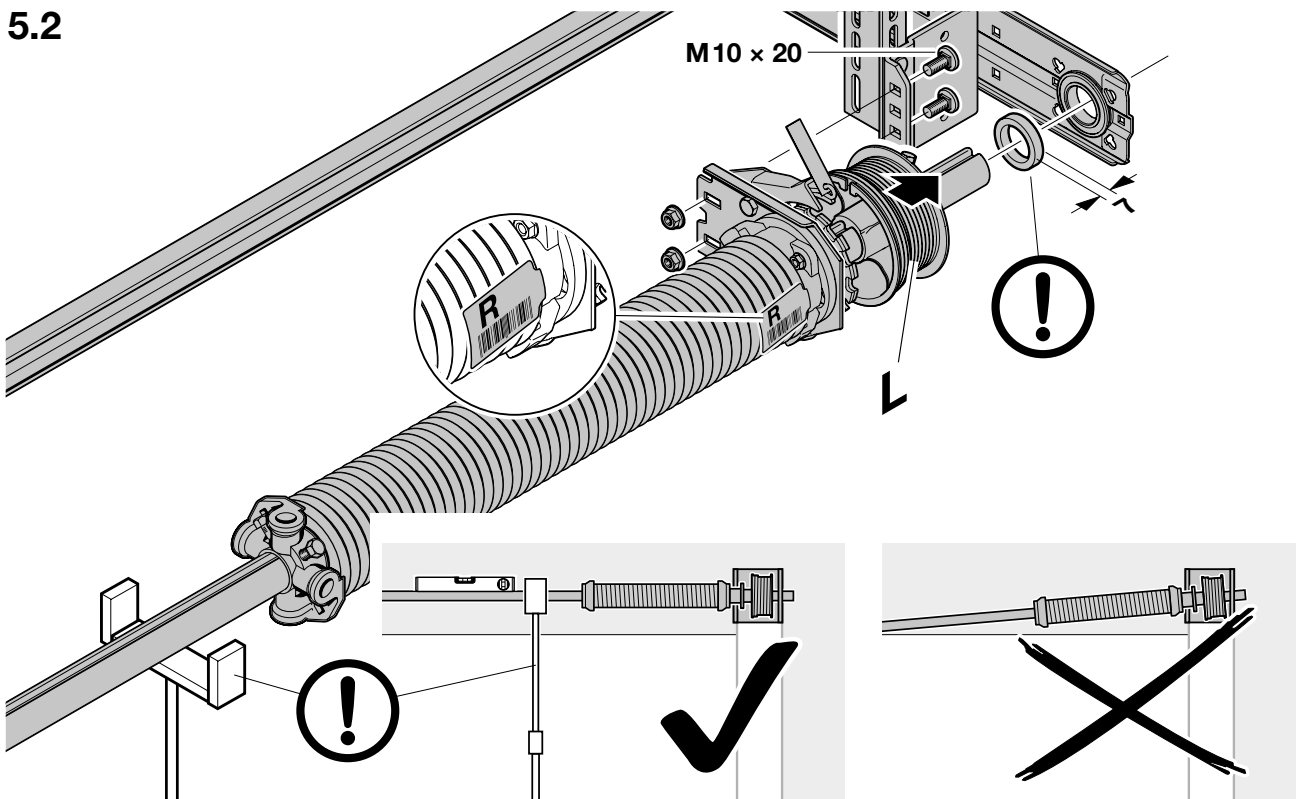

5.3

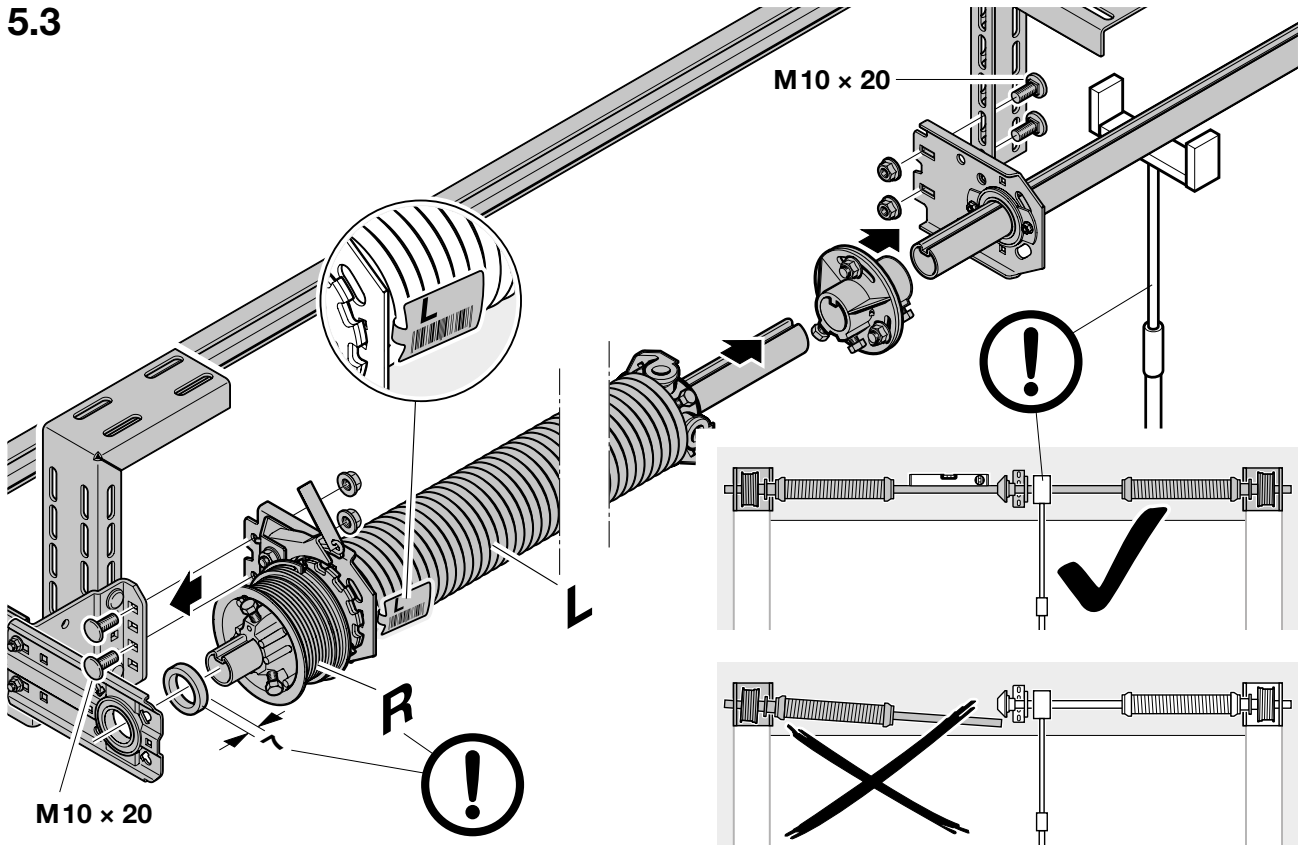

5.4

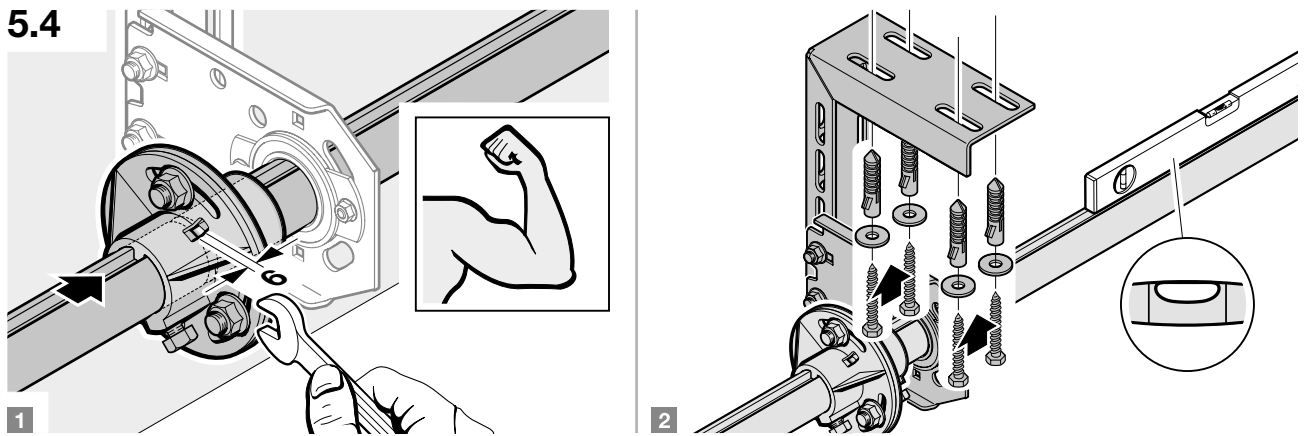

5.5

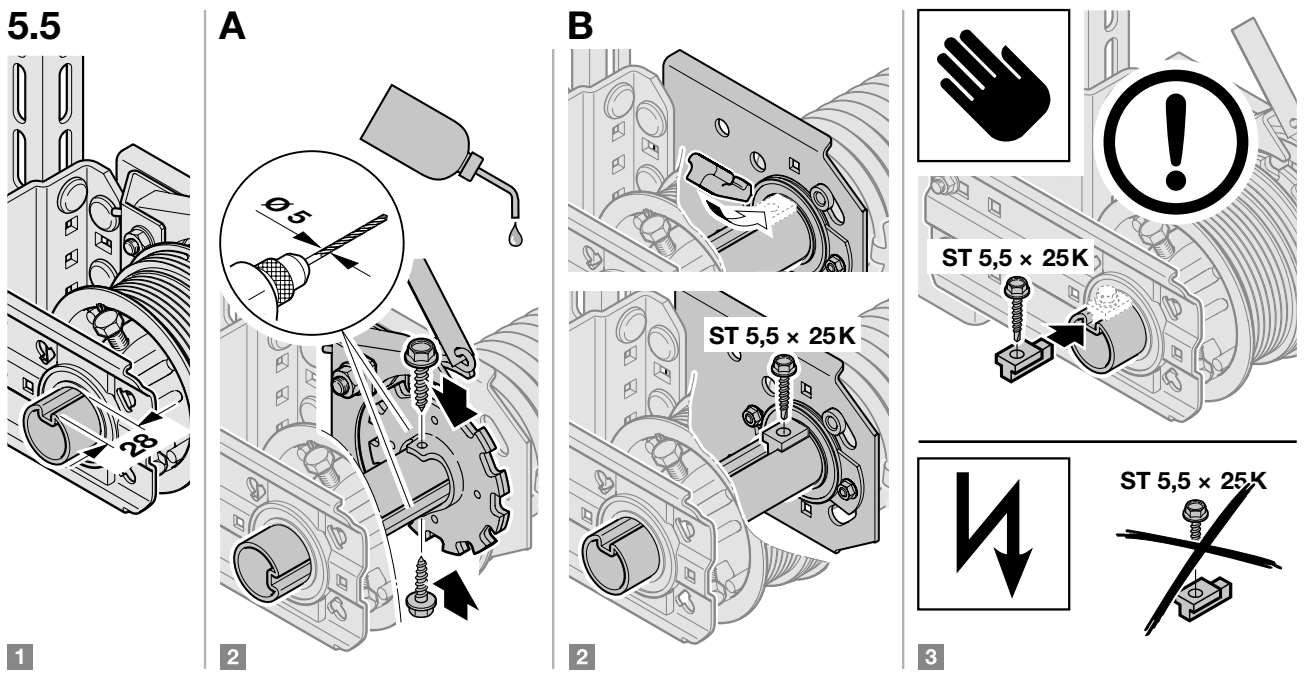

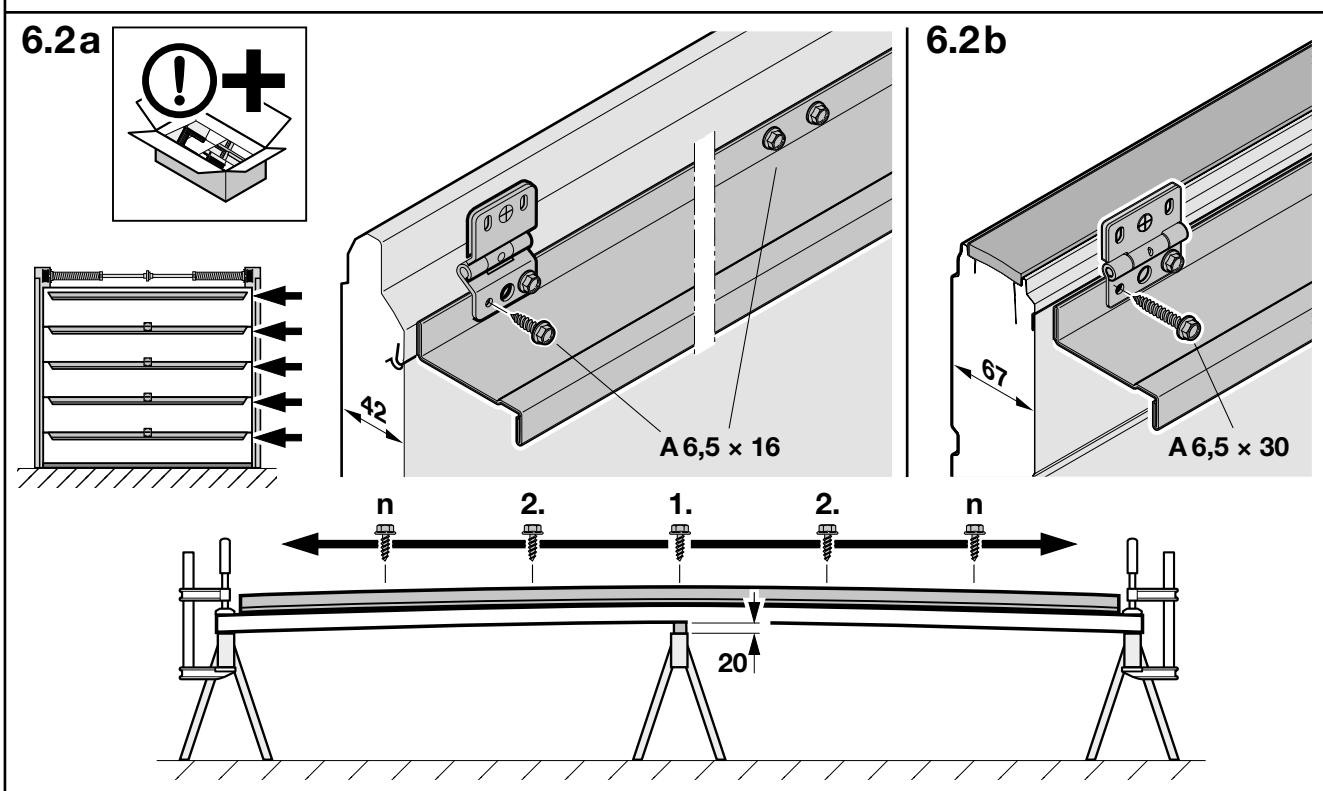
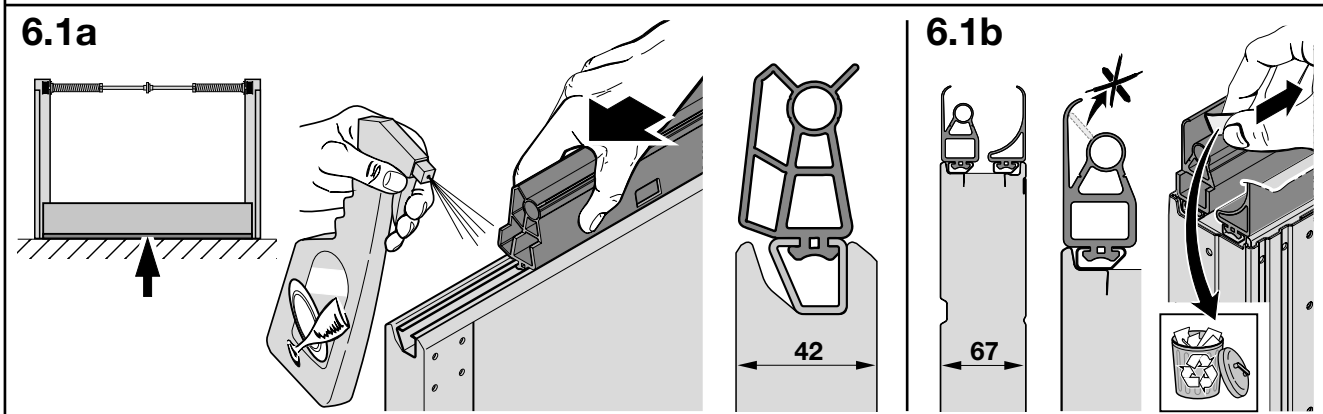
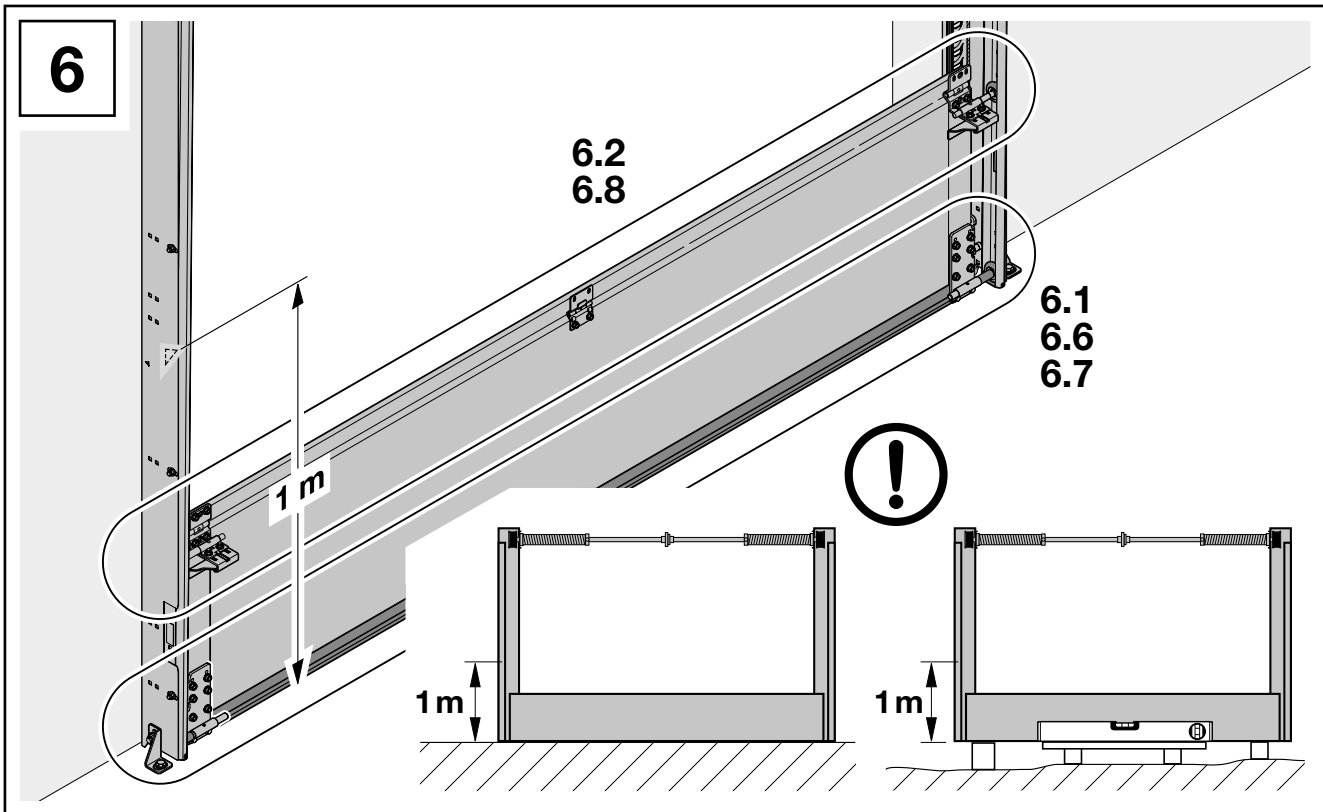

6.3

RM	
≤ 3000	4
3001 - 4000	6
4001 - 5000	8

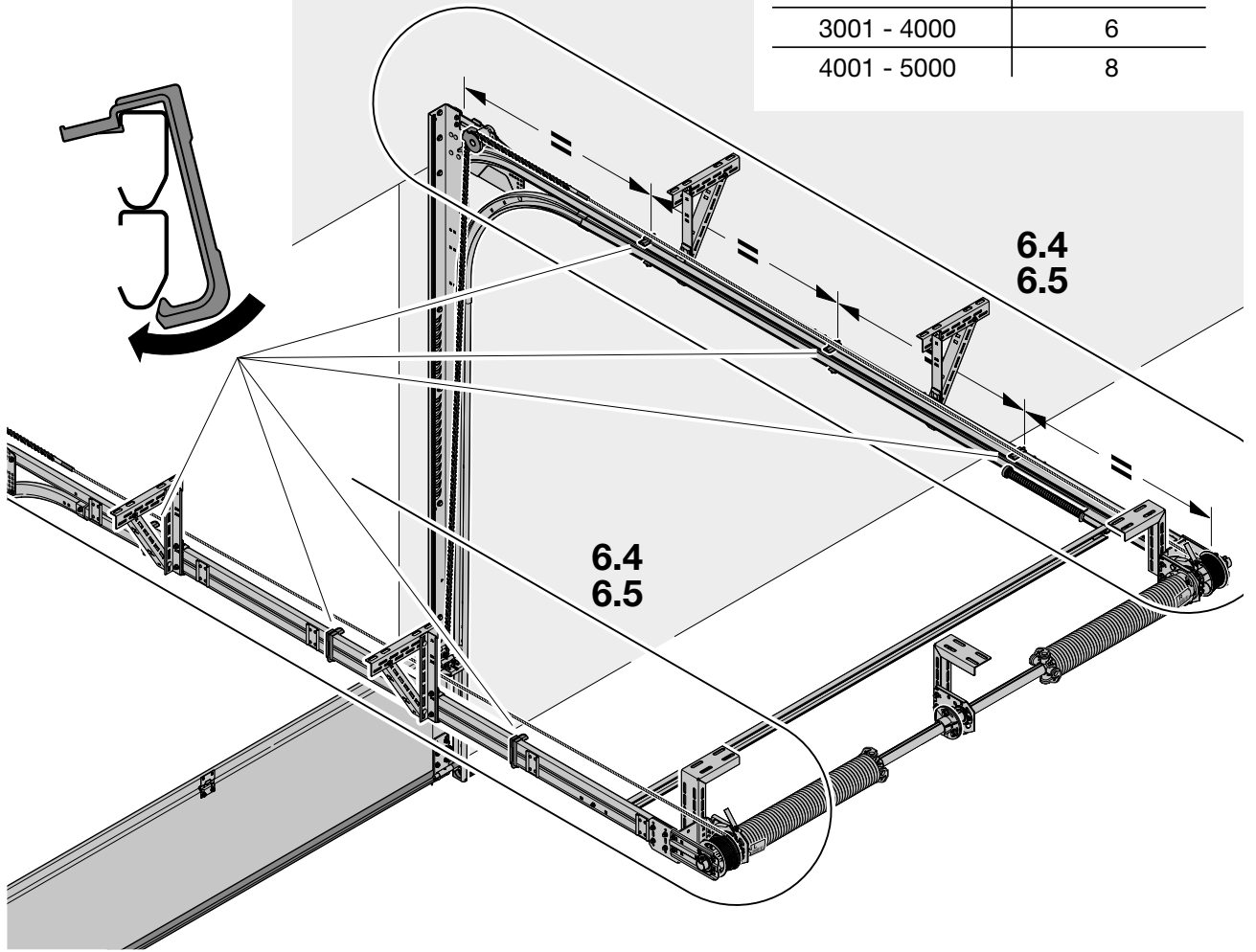

6.4

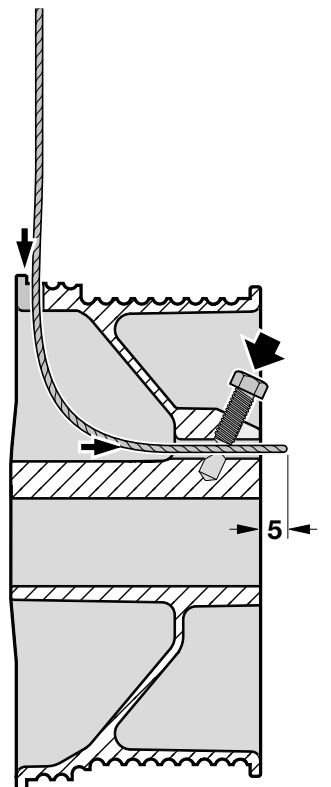
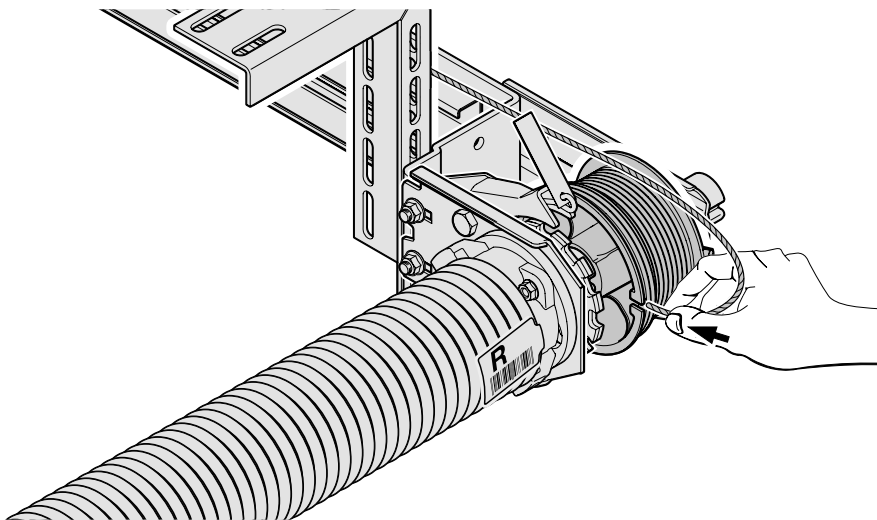
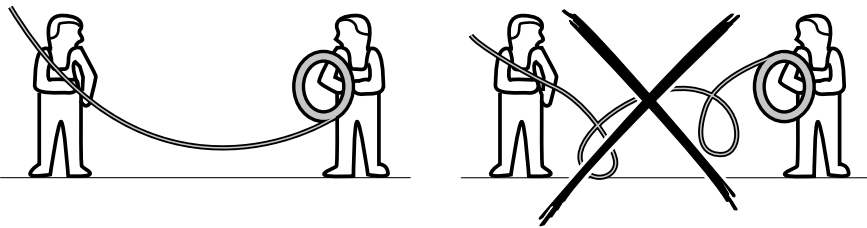

6.5

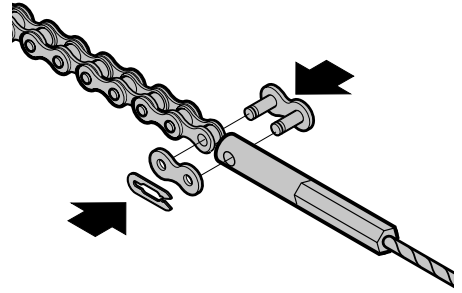
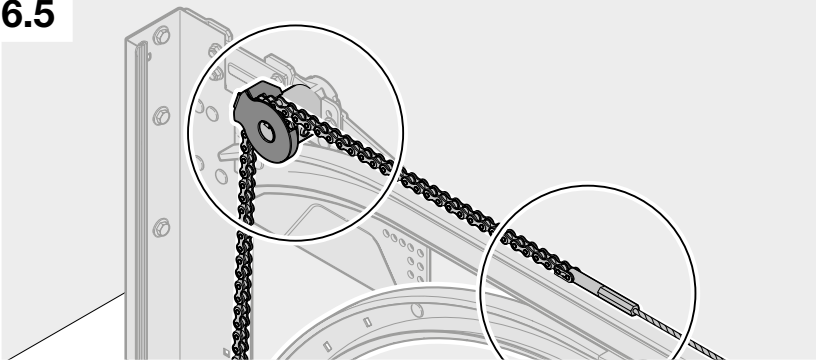

1

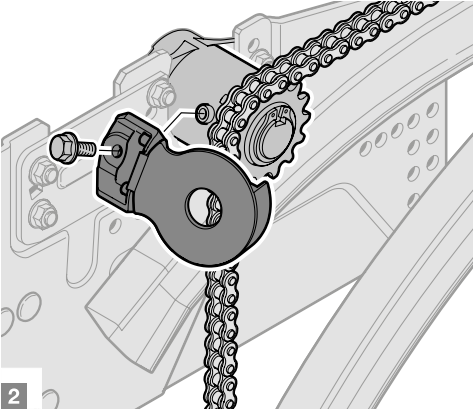

2

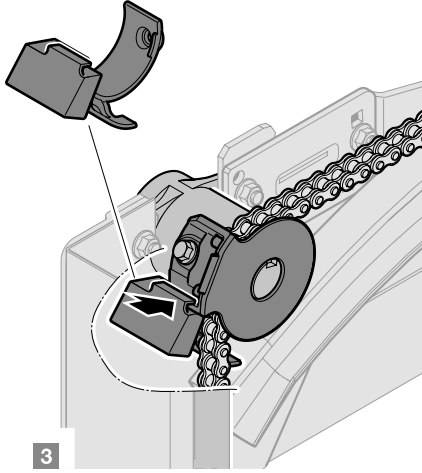
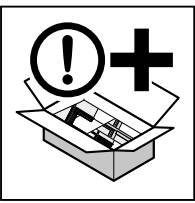
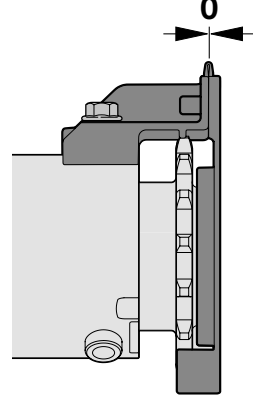
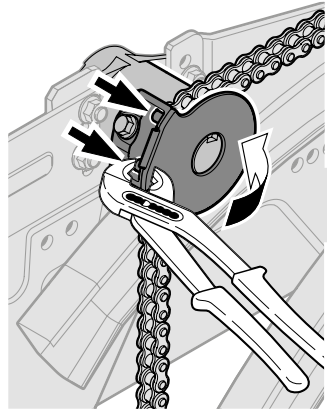

3

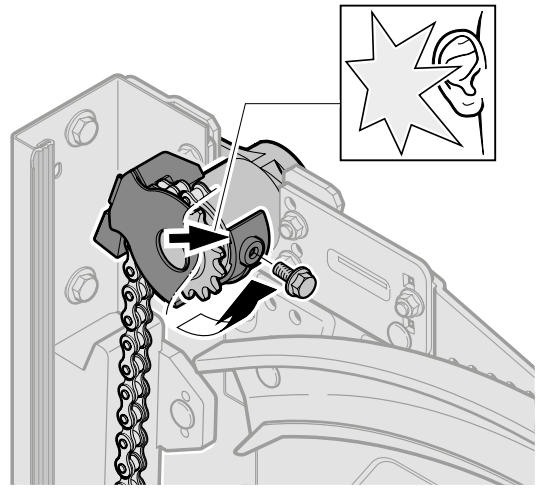

6.6

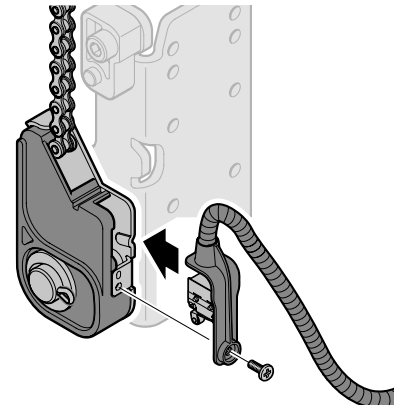
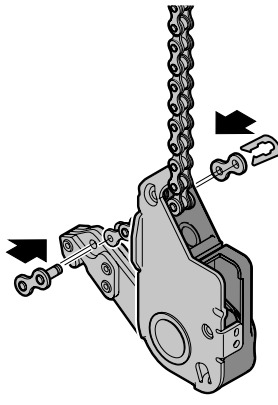
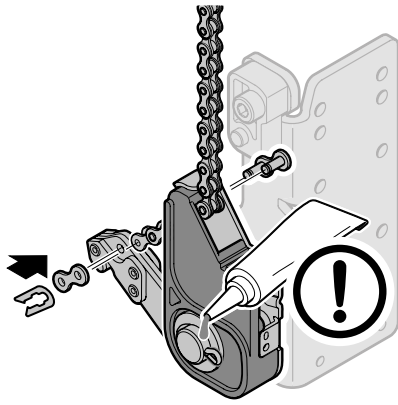
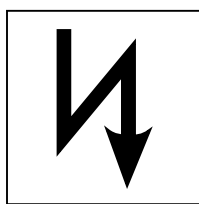
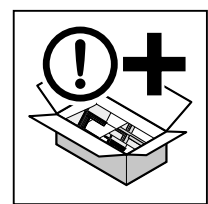
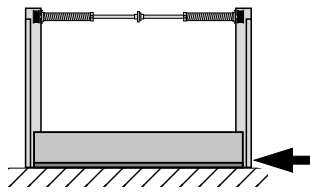
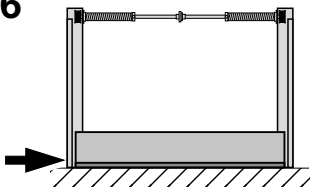

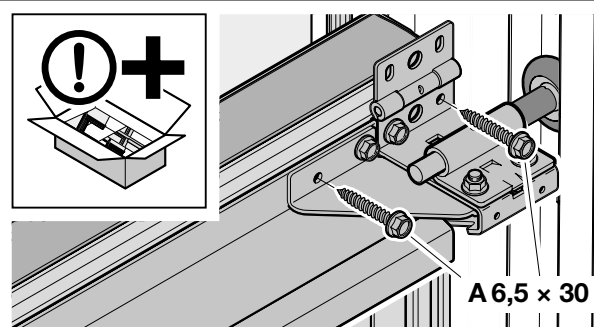
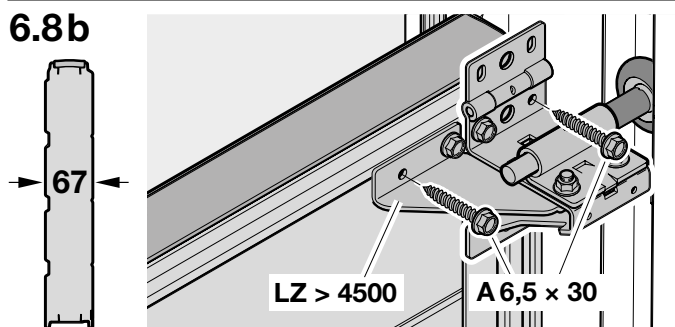
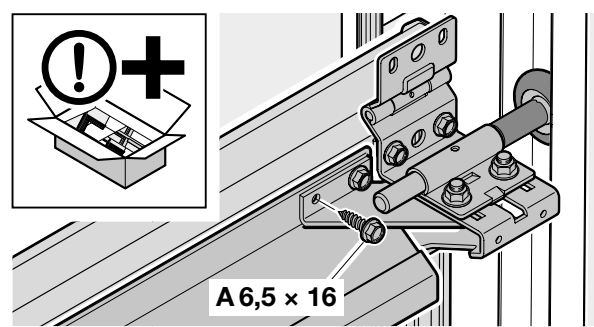
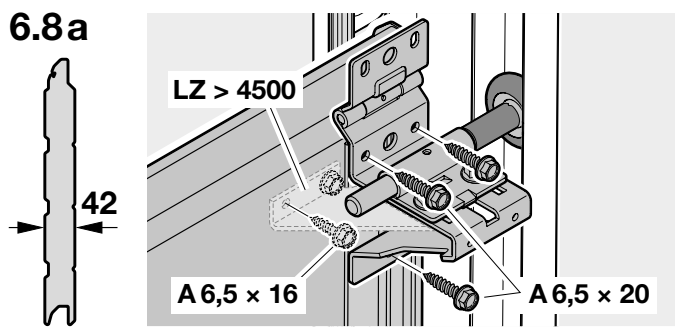
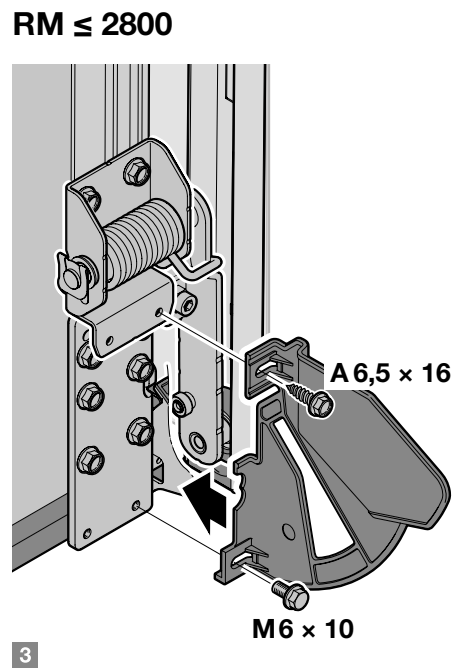
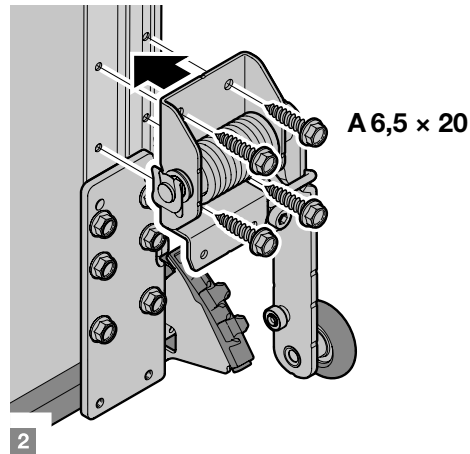
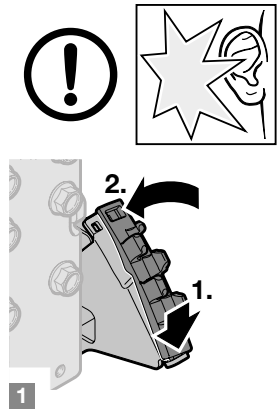
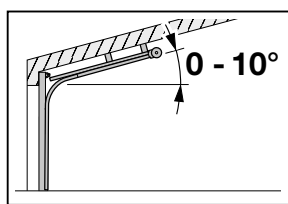
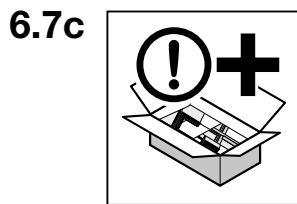
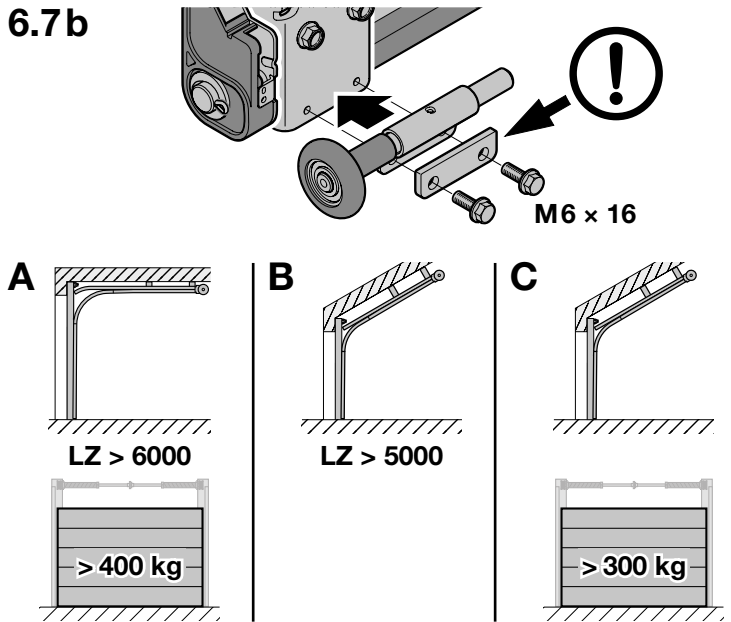
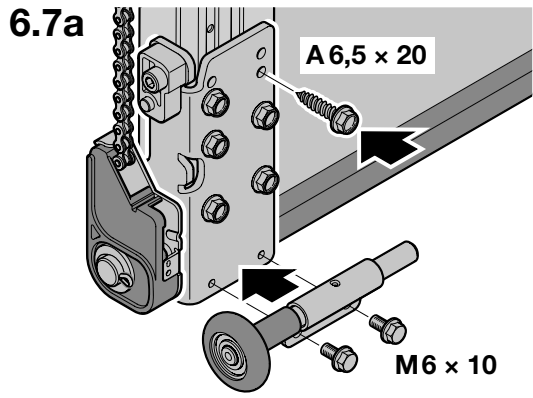

7

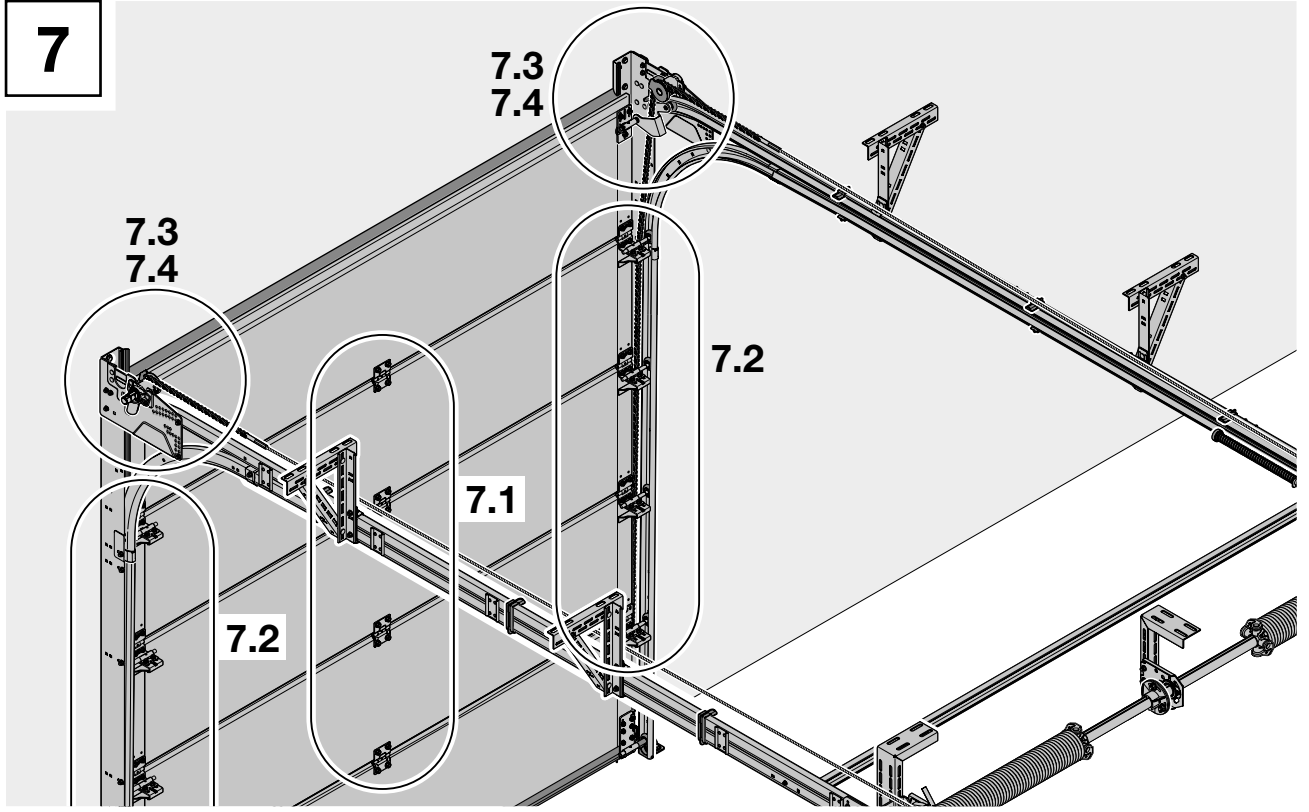

7.1a

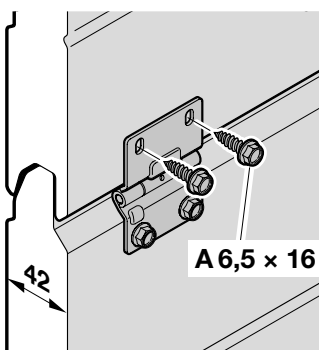

7.1b

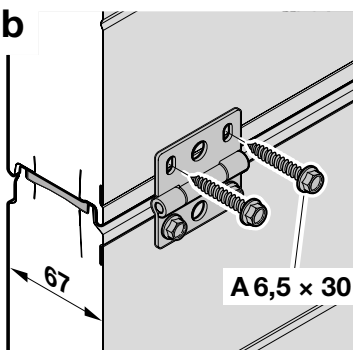

7.2

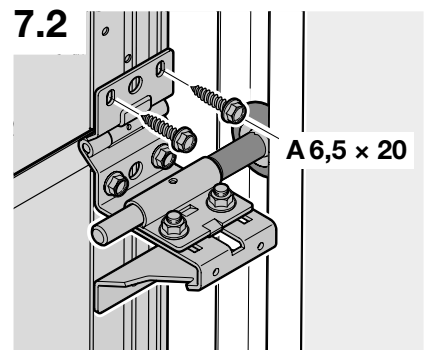

7.3

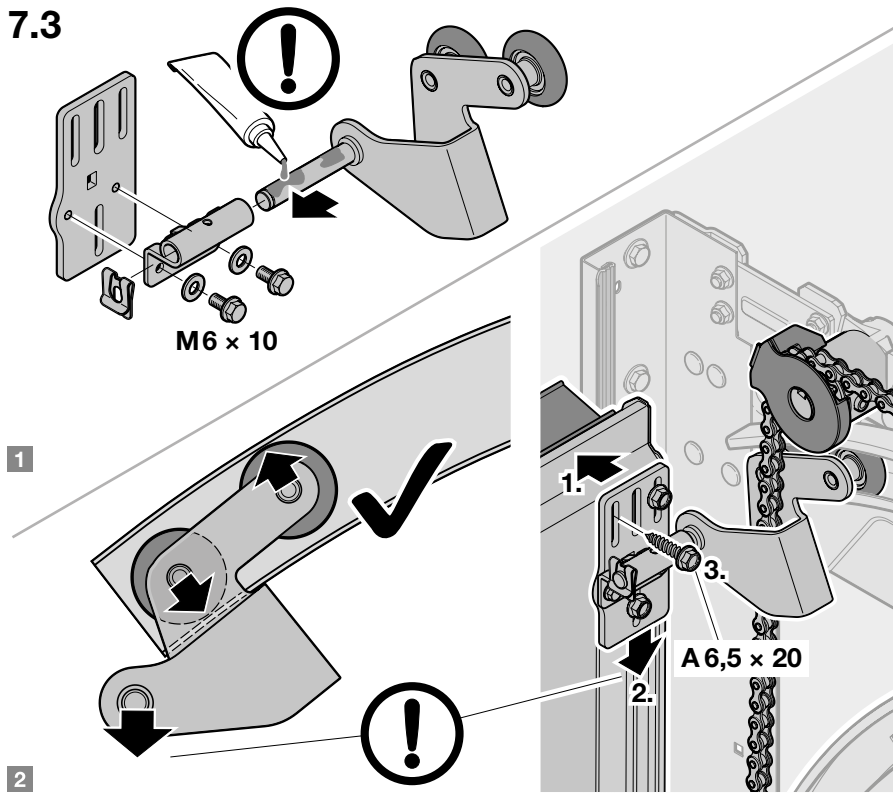

7.4

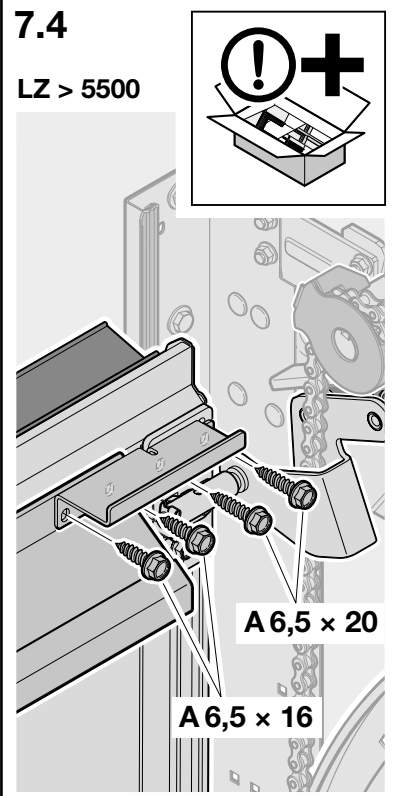

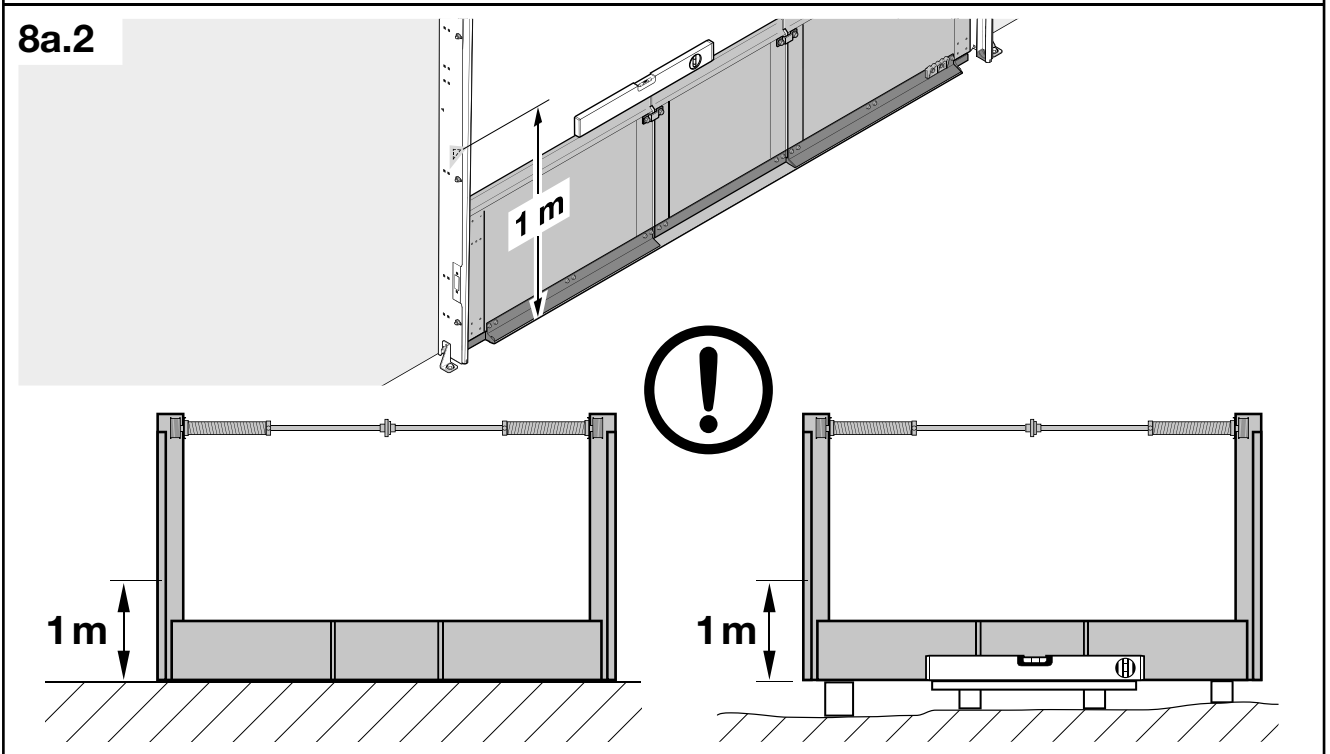
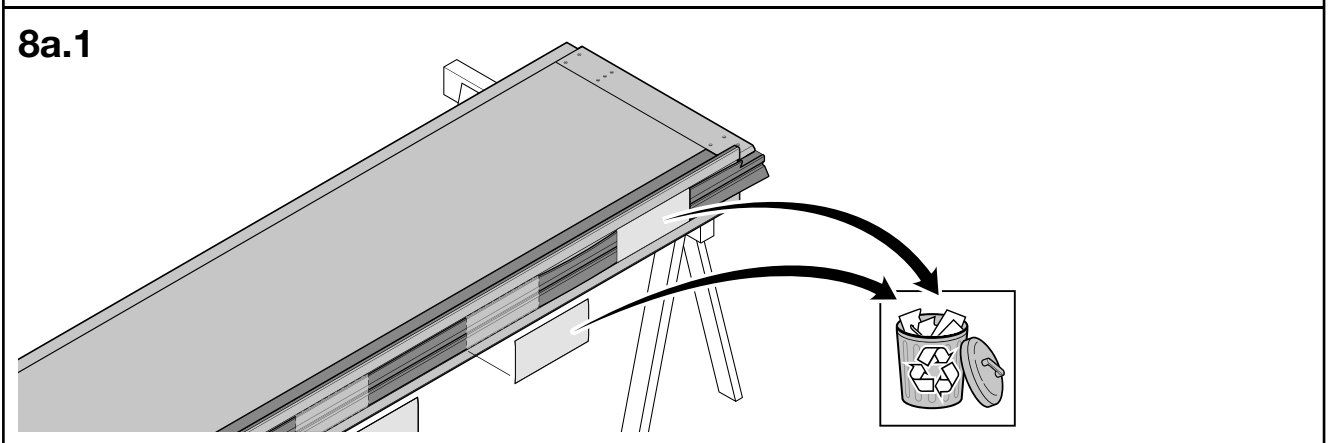
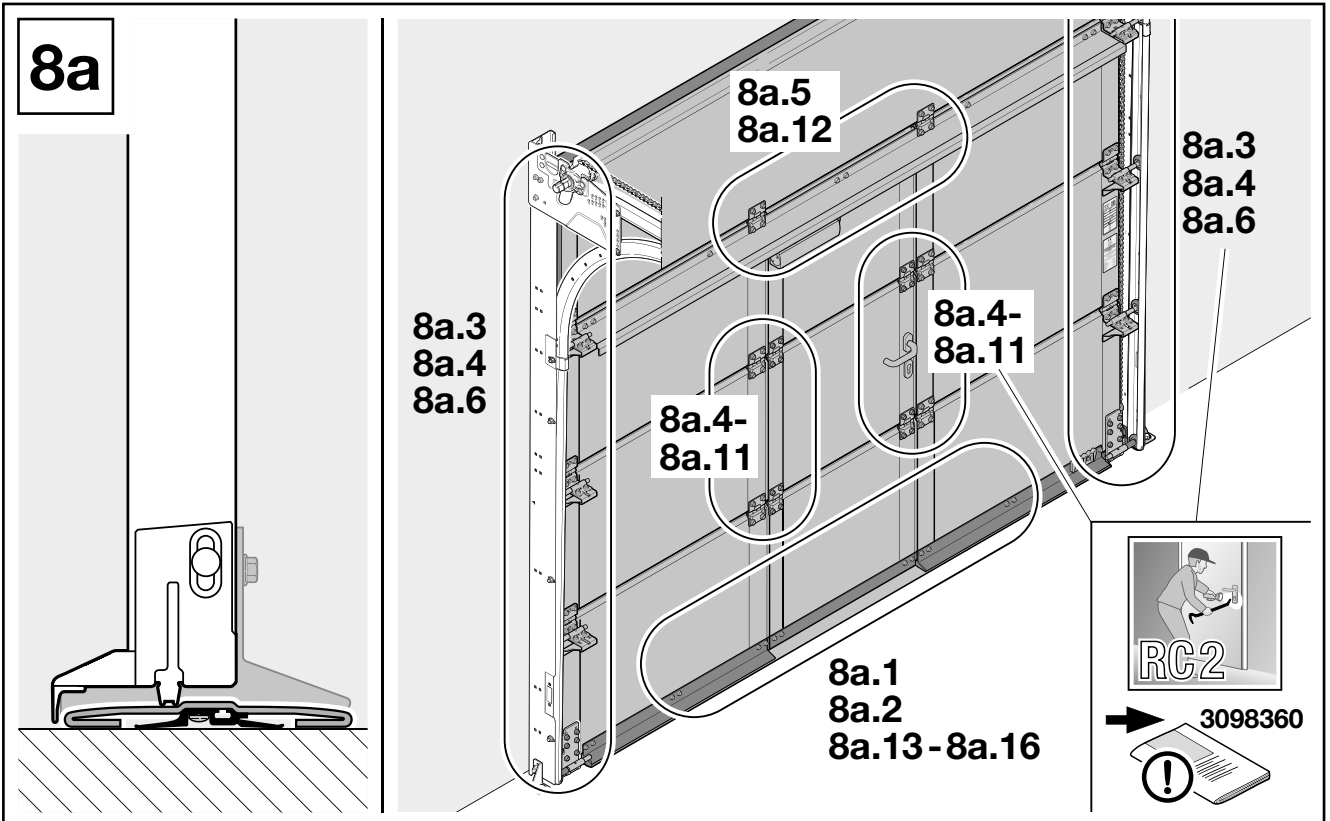

8a.3

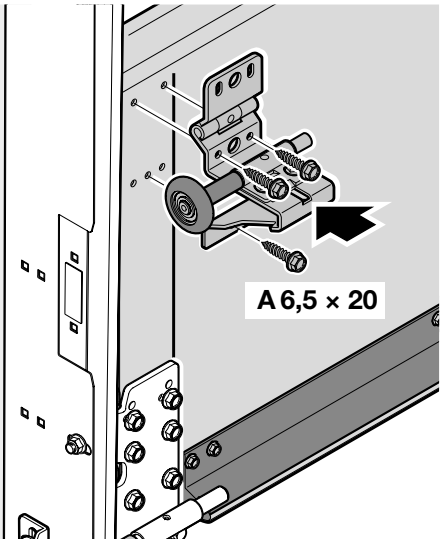
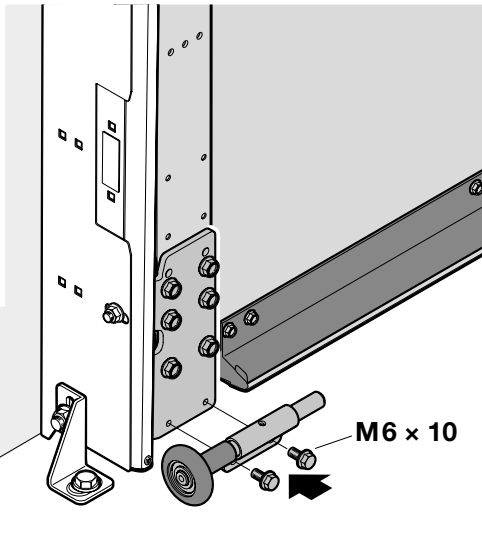
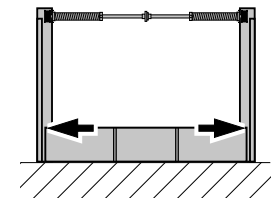

1

2

8a.4

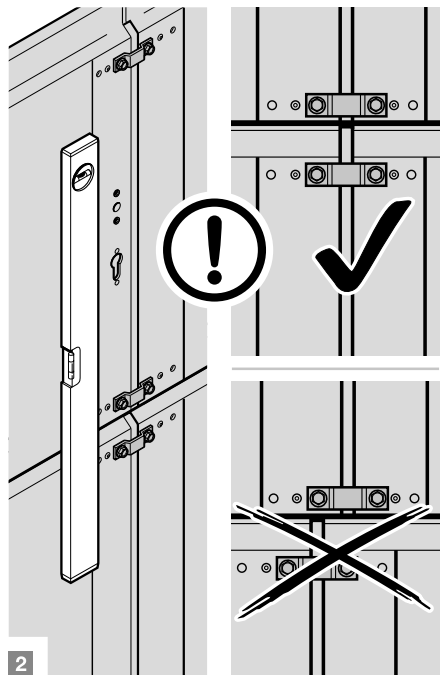
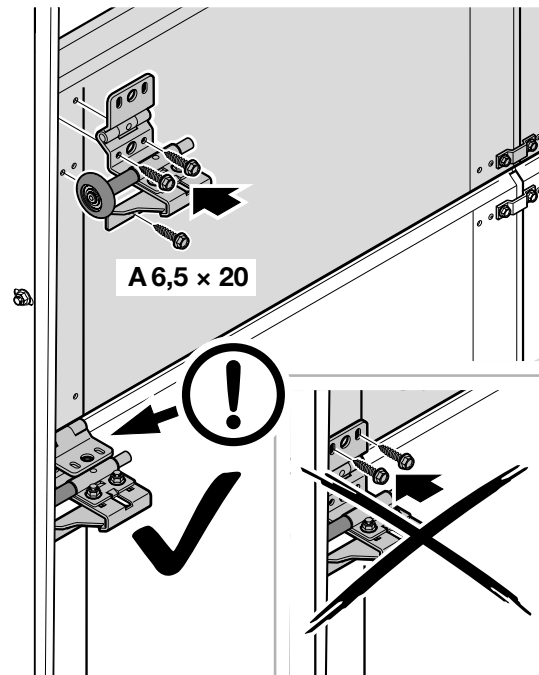
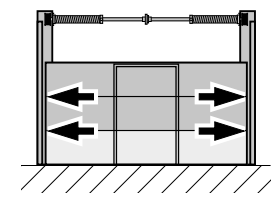

1

2

8a.5

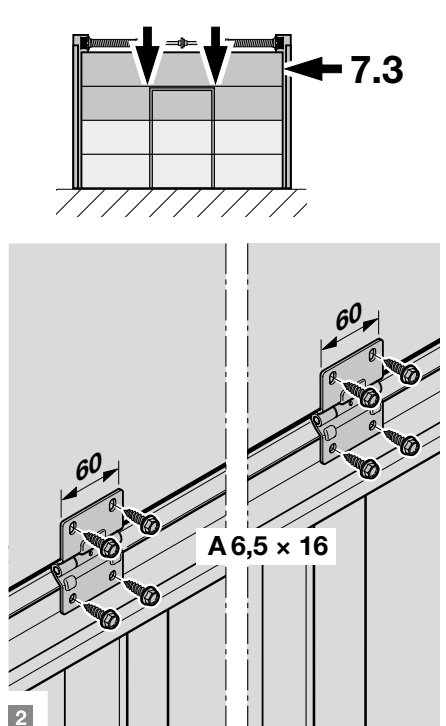
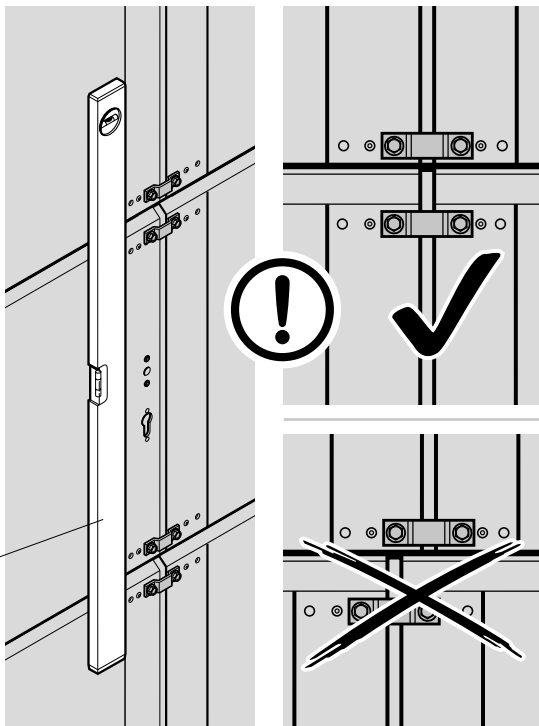
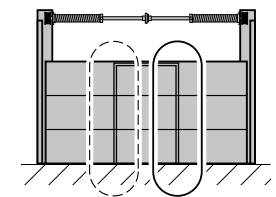

1

2

8a.6

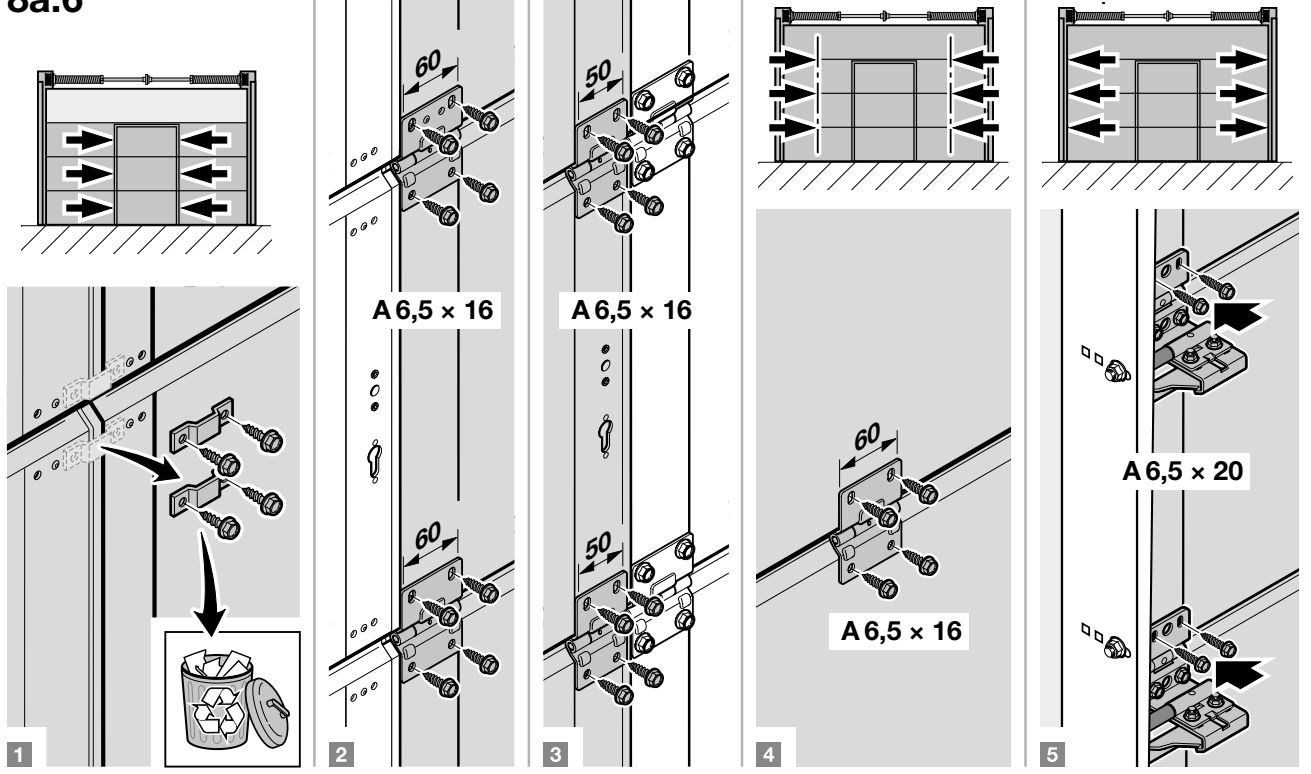

8a.7

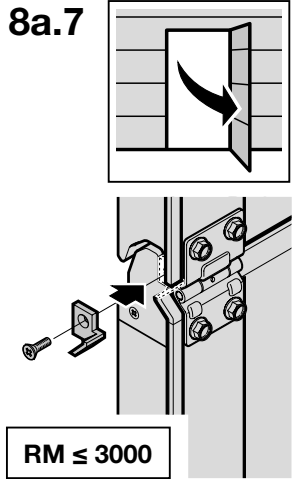

8a.8

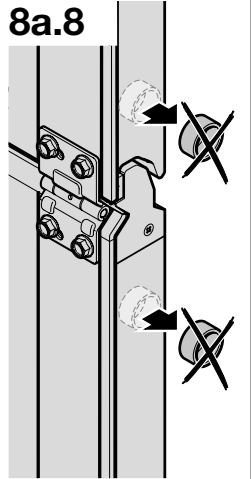

8a.9

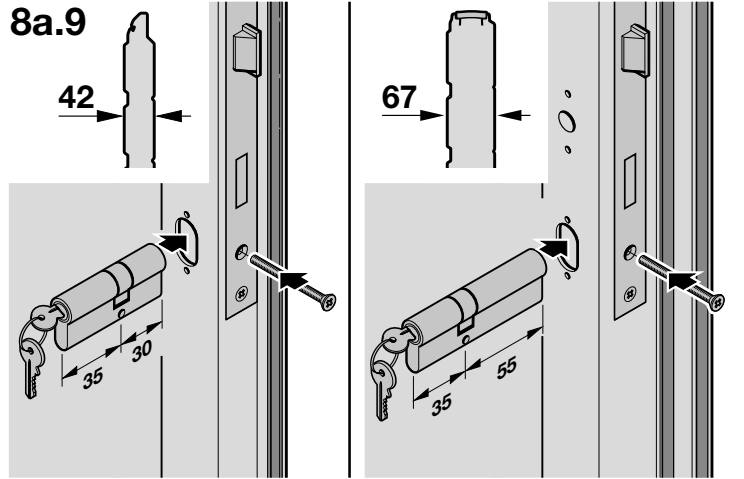

8a.10

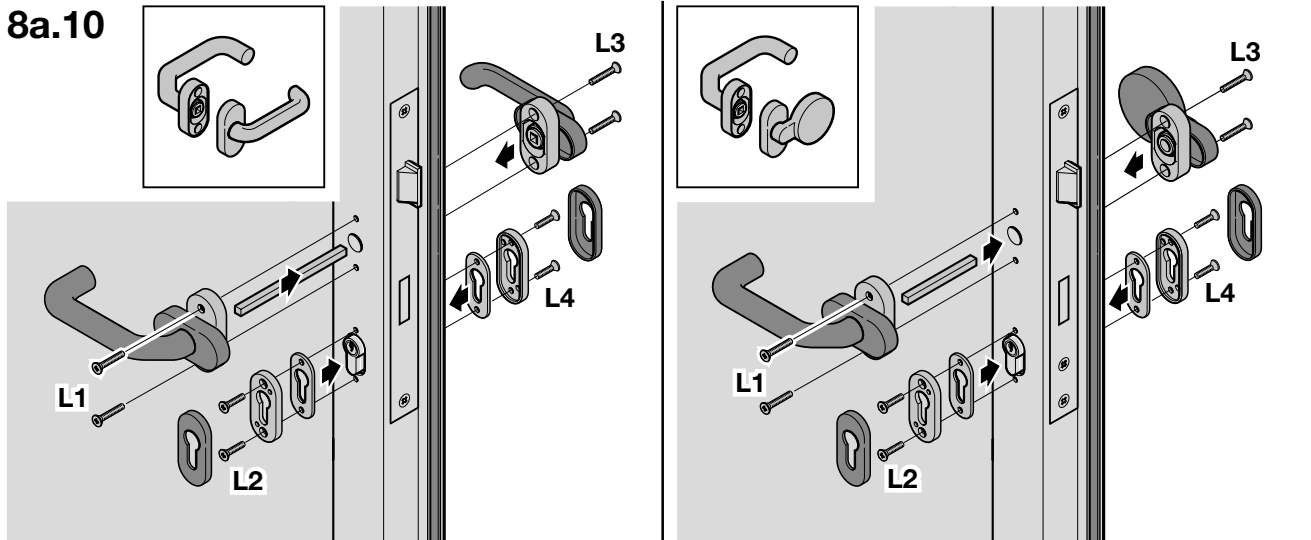

	L1	L2	L3	L4
	25	20	22	16

8a.11

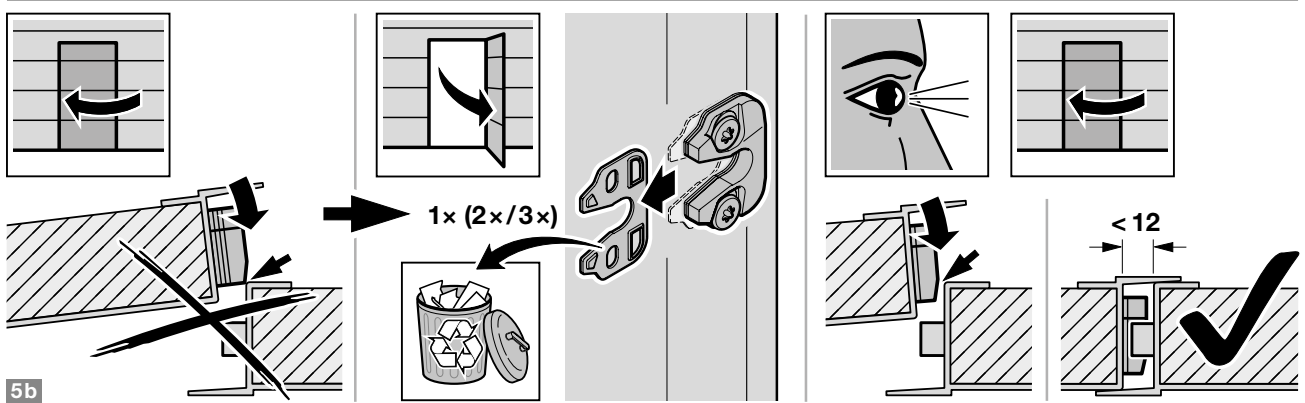
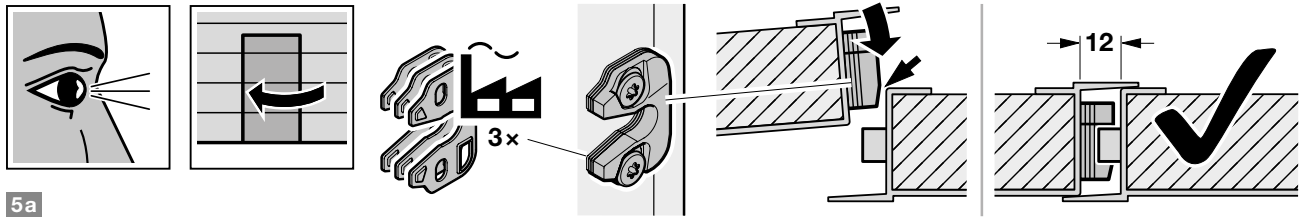
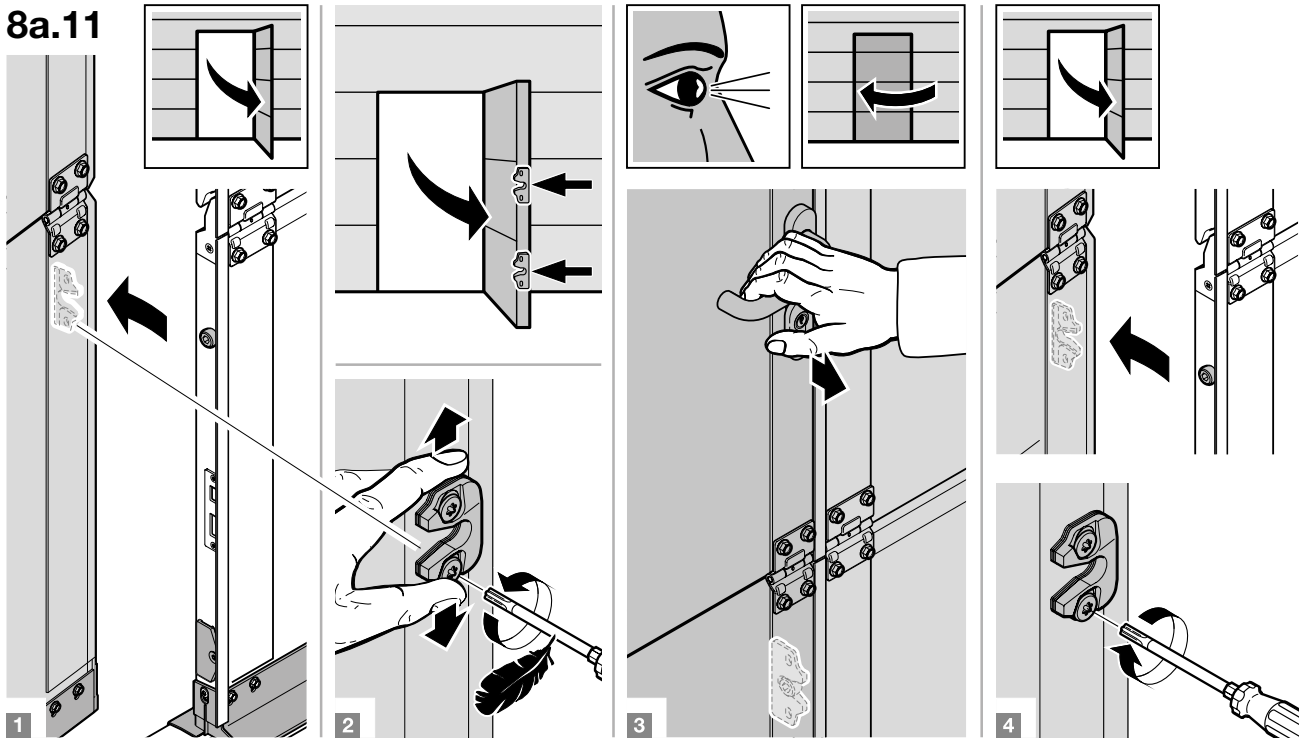

8a.12

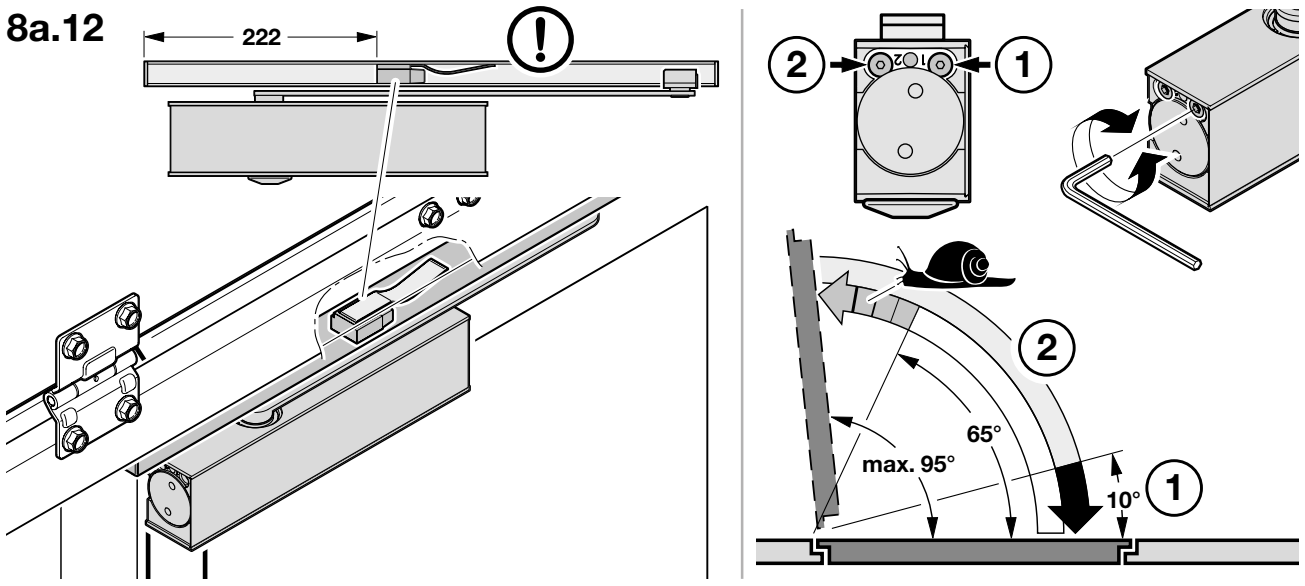

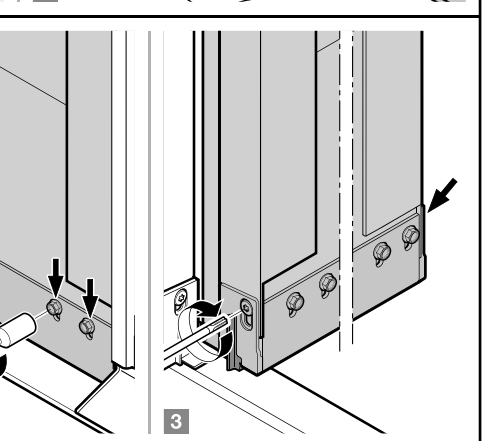
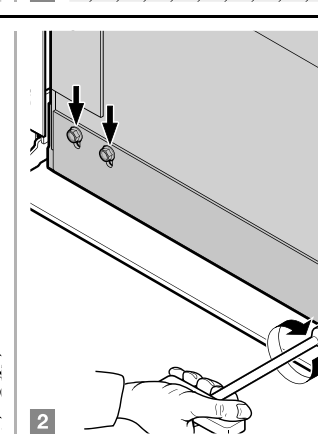
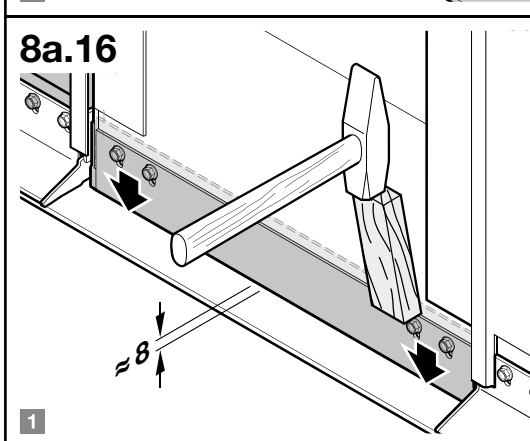
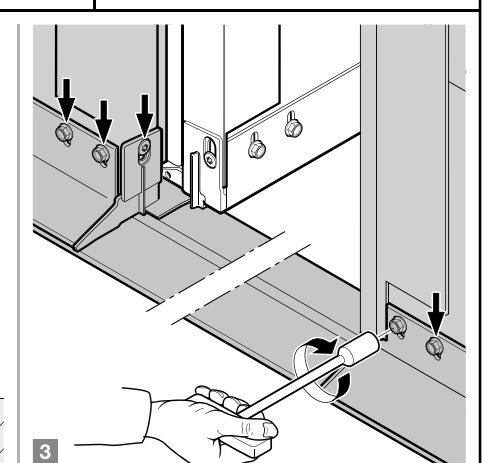
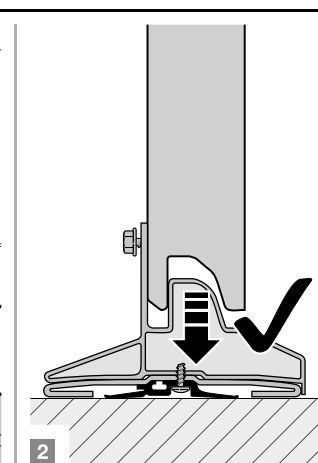
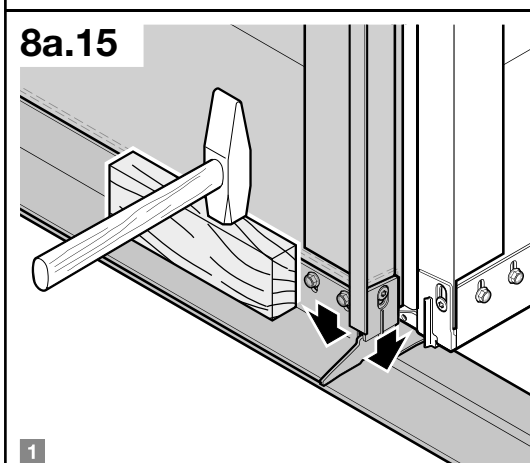
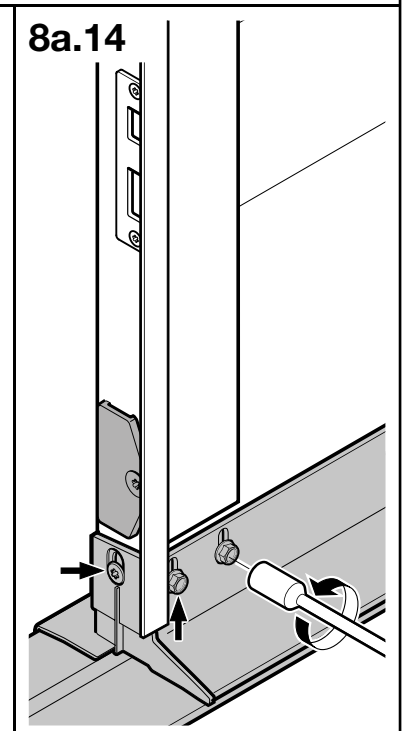
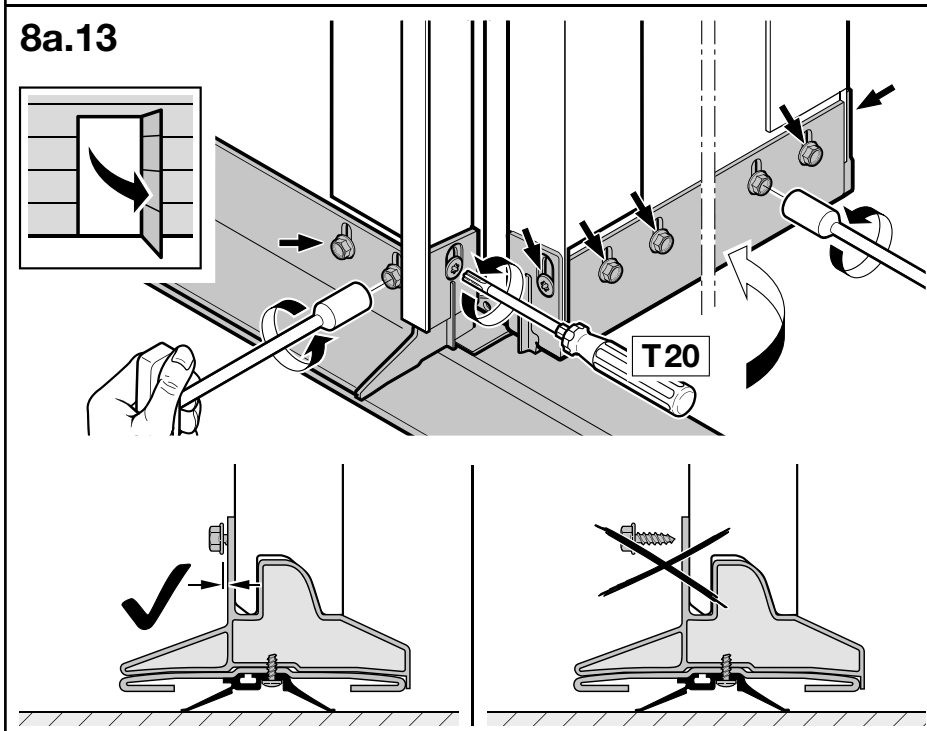
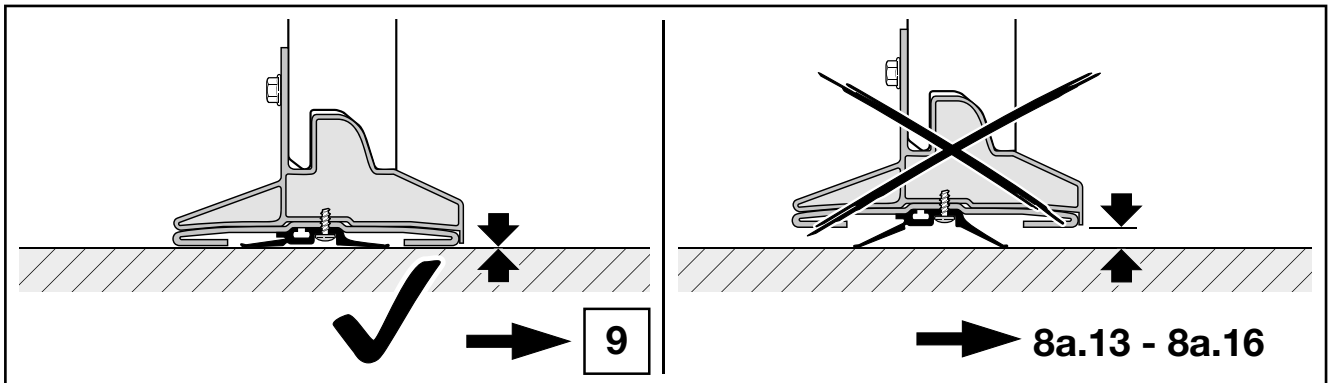

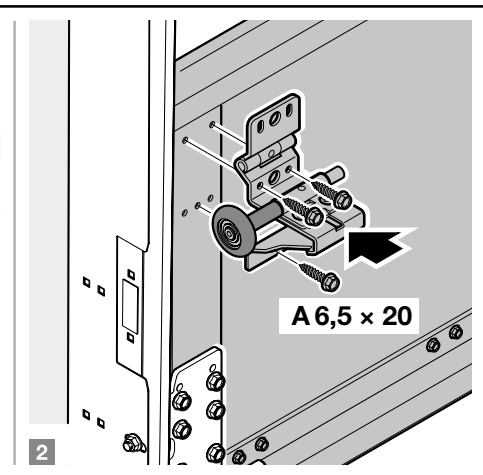
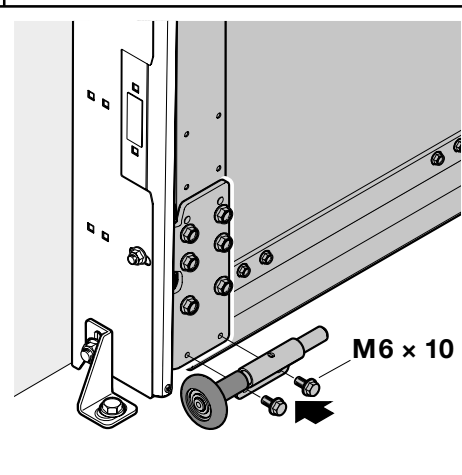
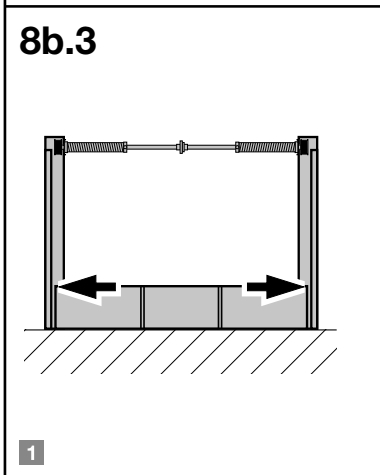
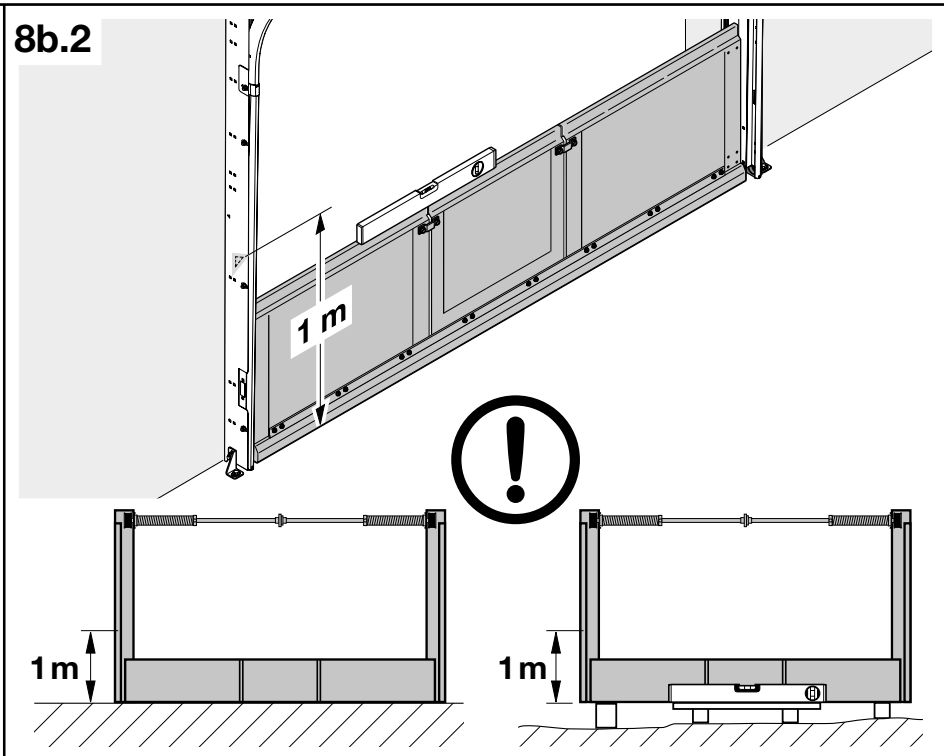
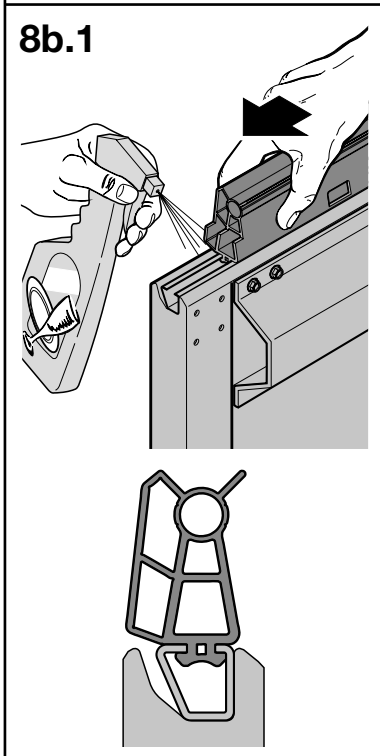
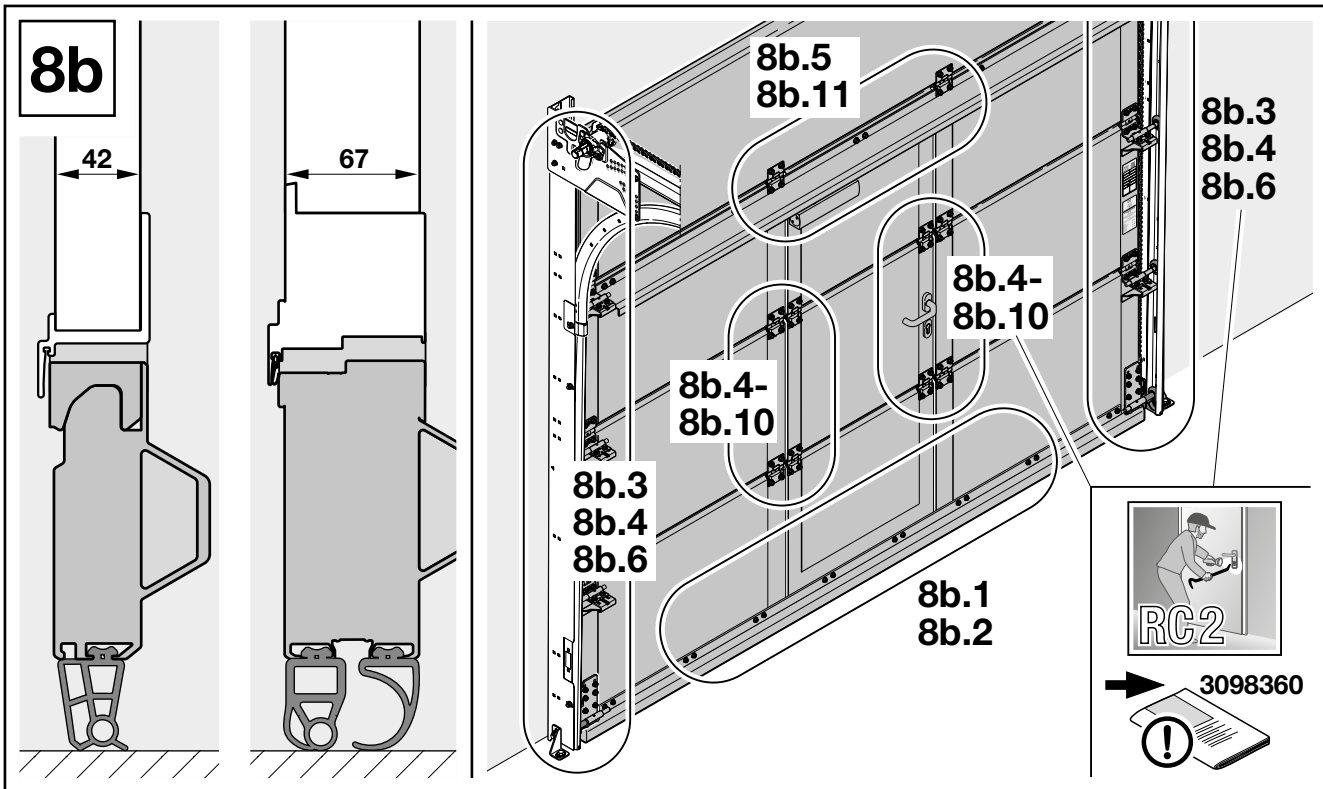

8b.4

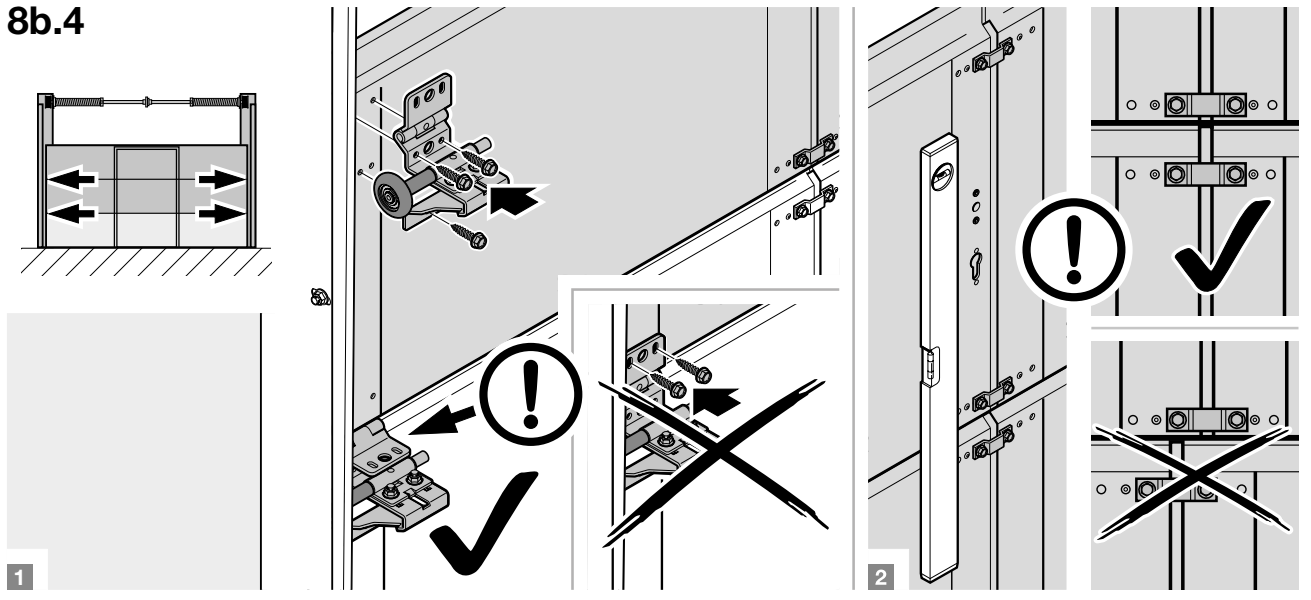

8b.5

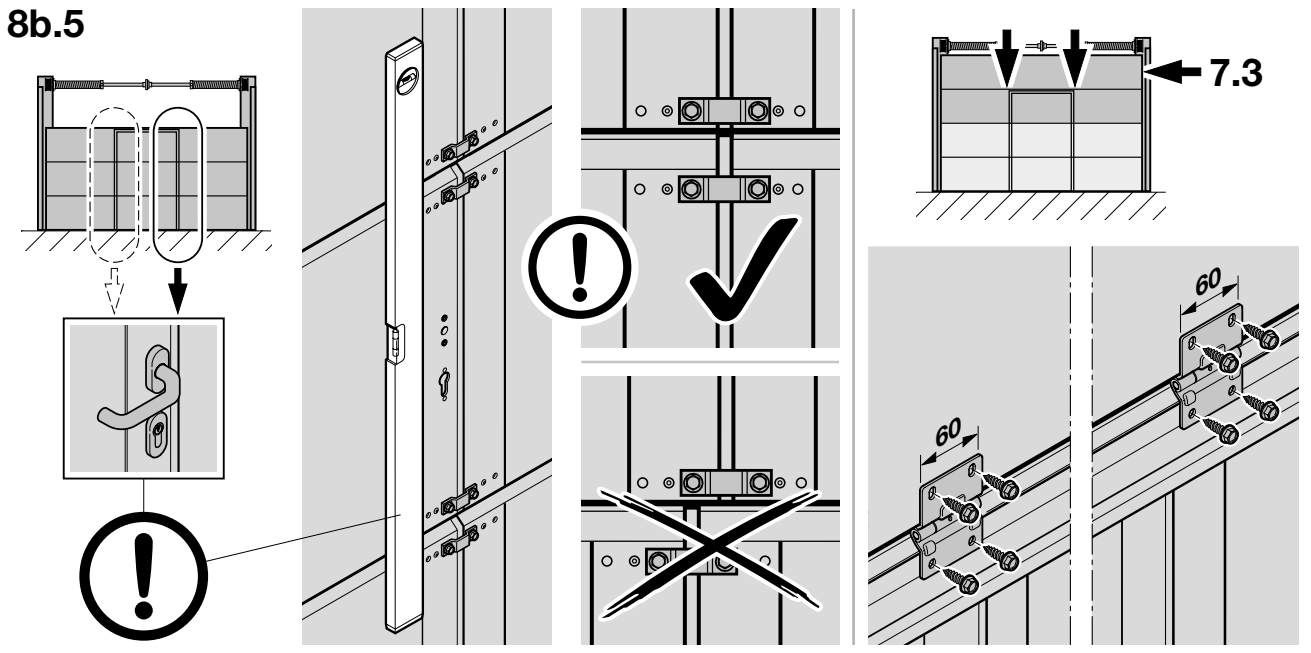

8b.6

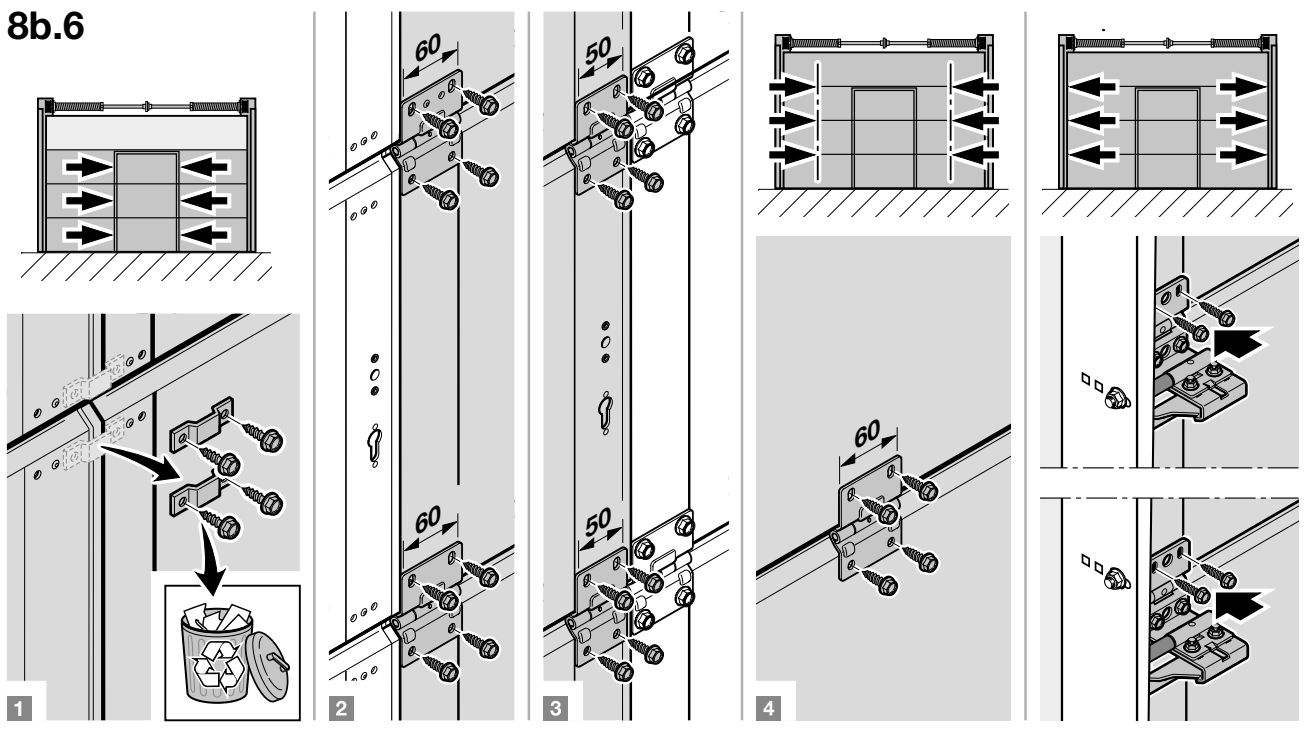

8b.7

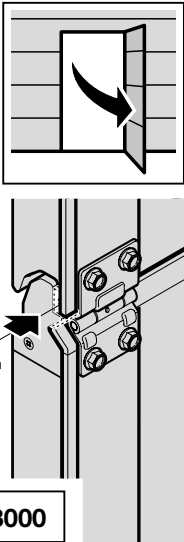

RM ≤ 3000

8b.8

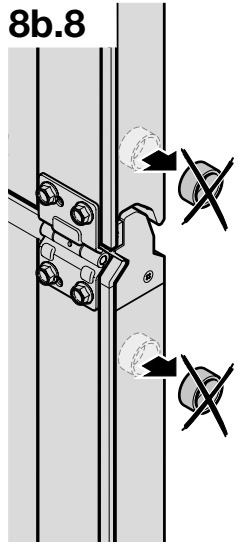

8b.9

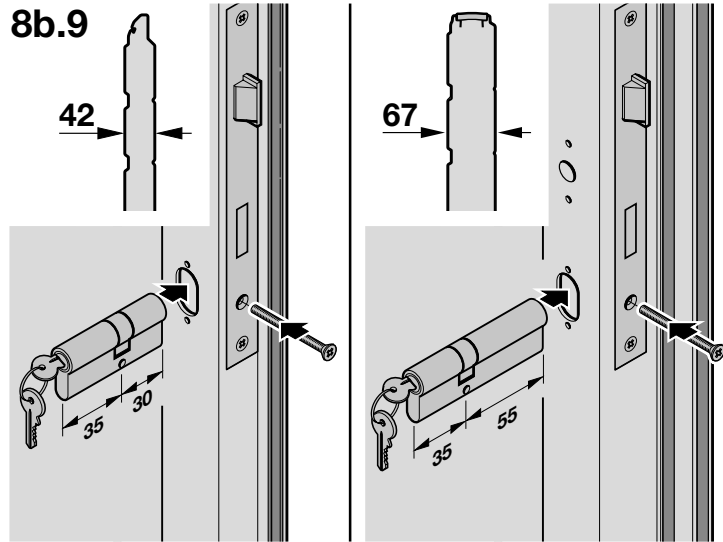

8b.10

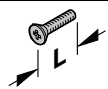
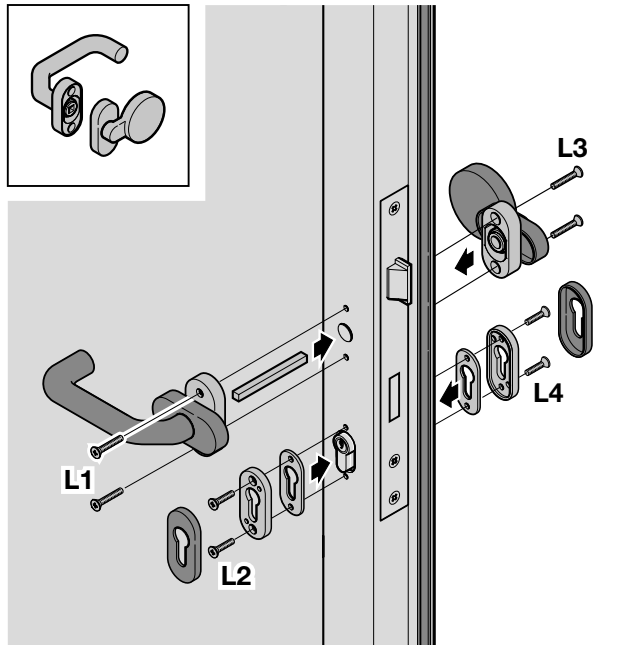
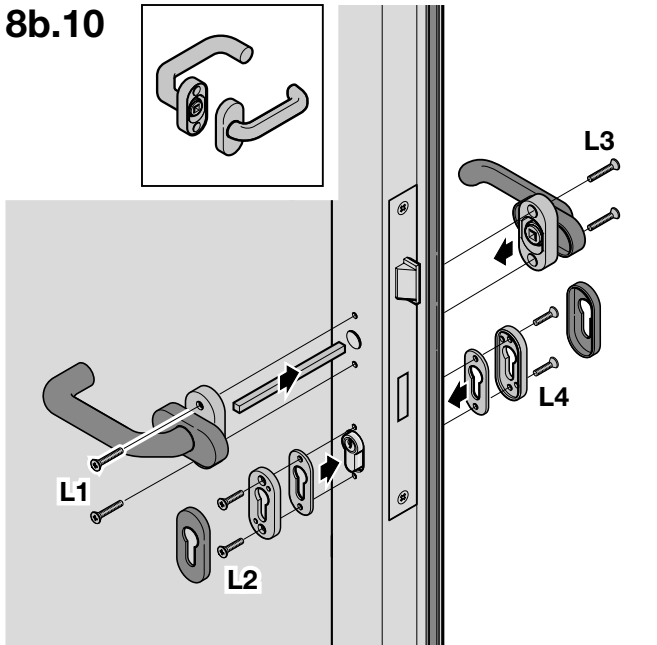

L1

L2

L3

L4

25

20

22

16

8b.11

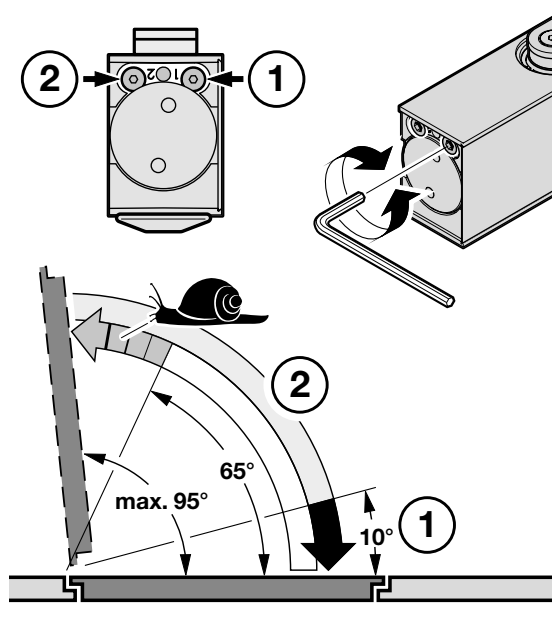
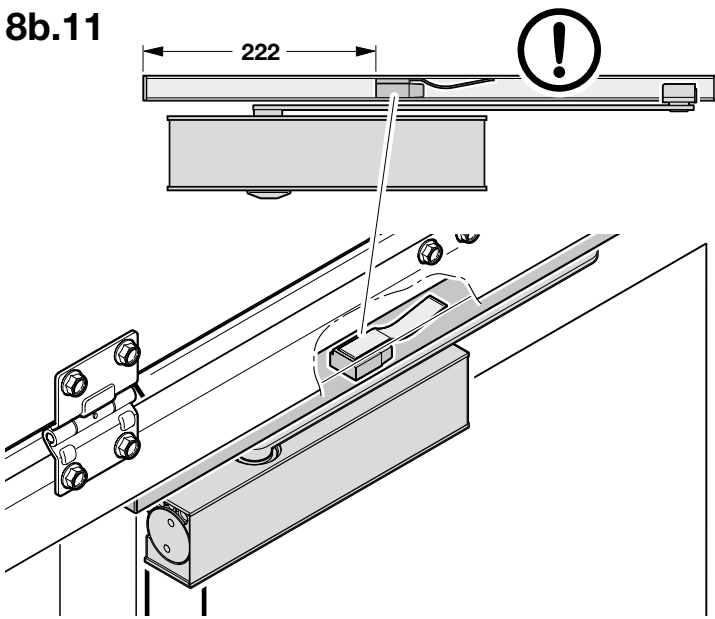

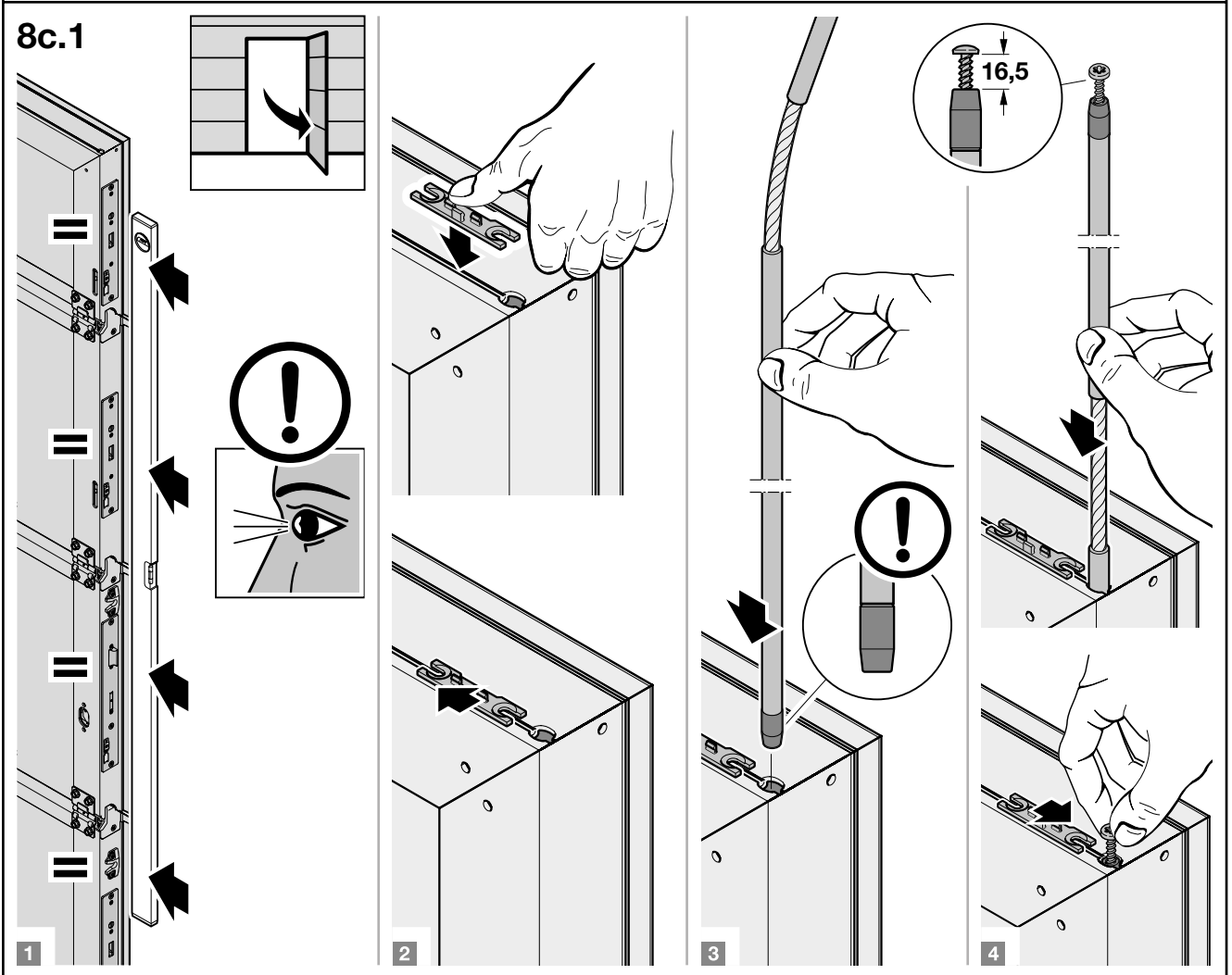
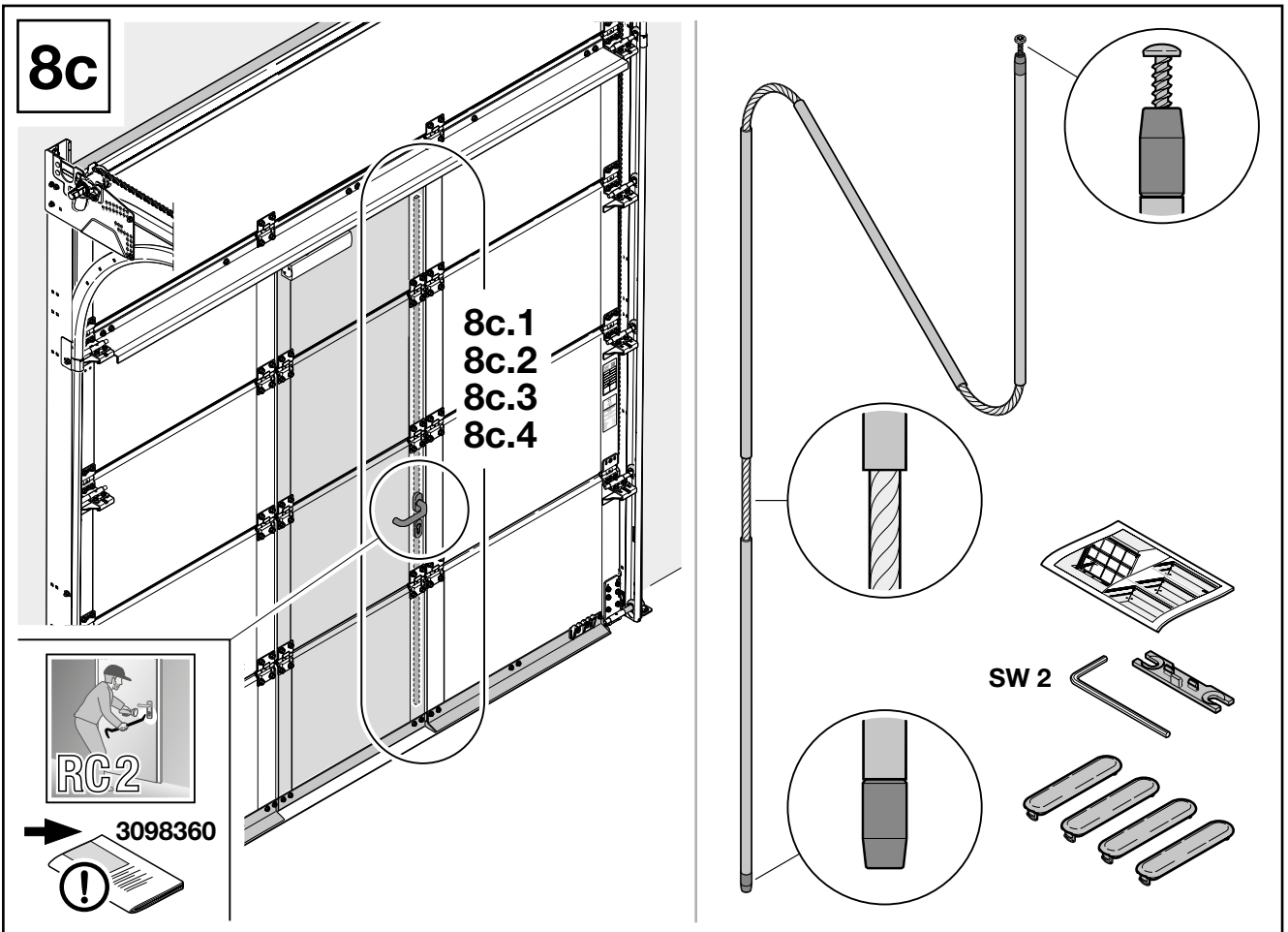

8c.2

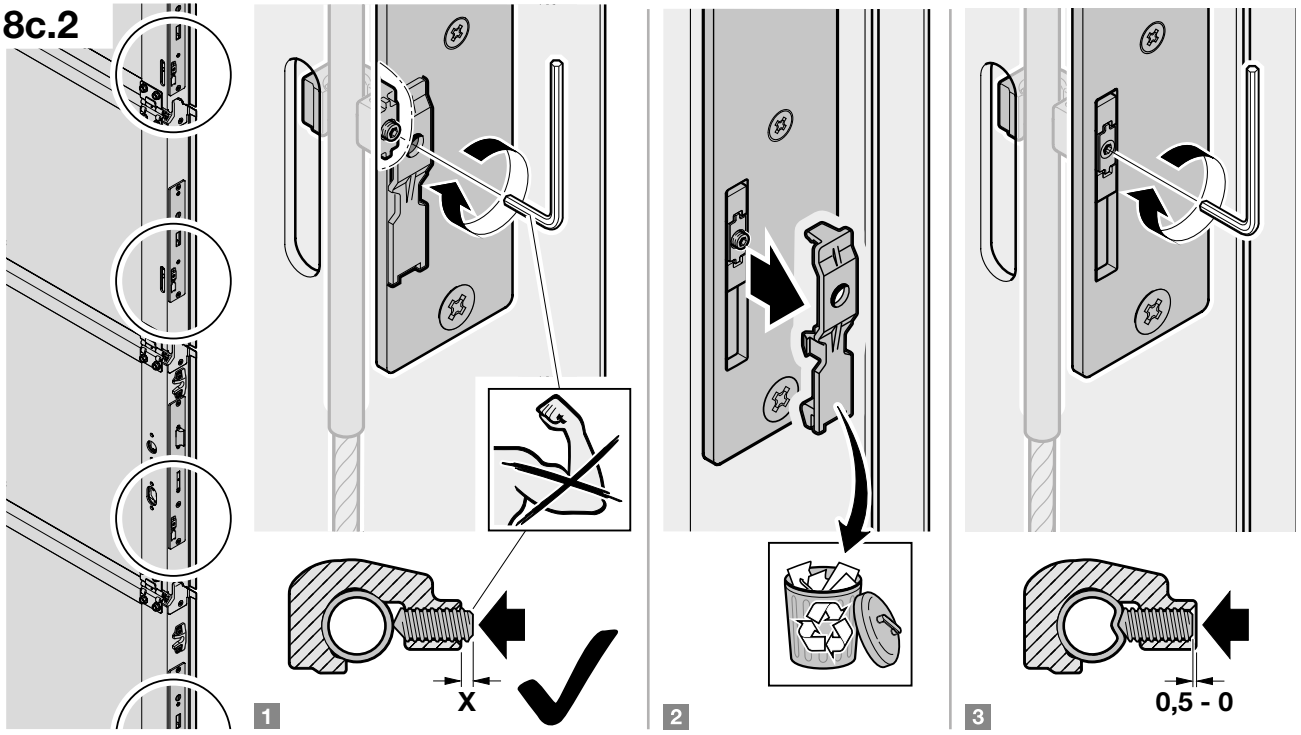

8c.3

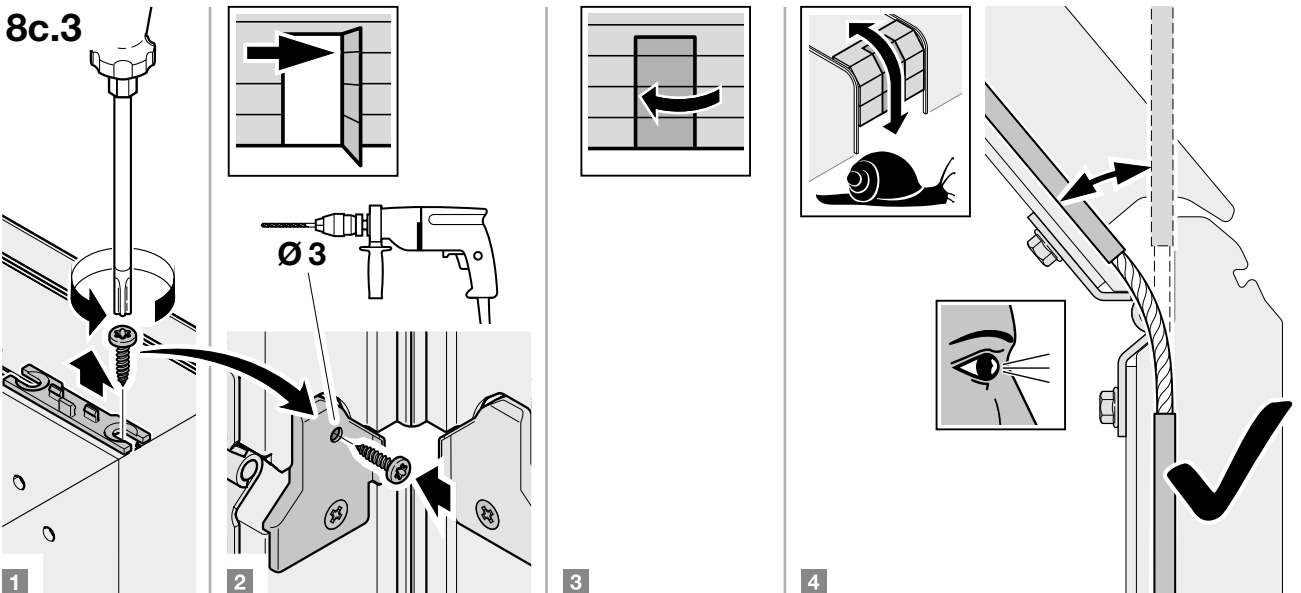

8c.4

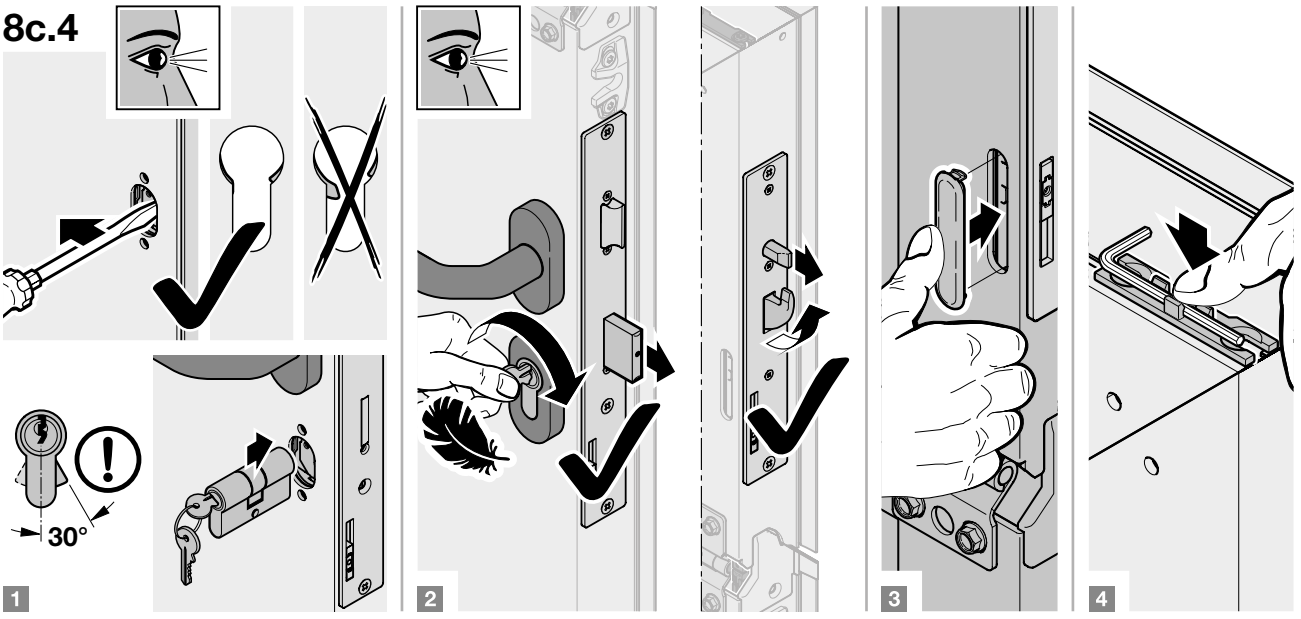

9

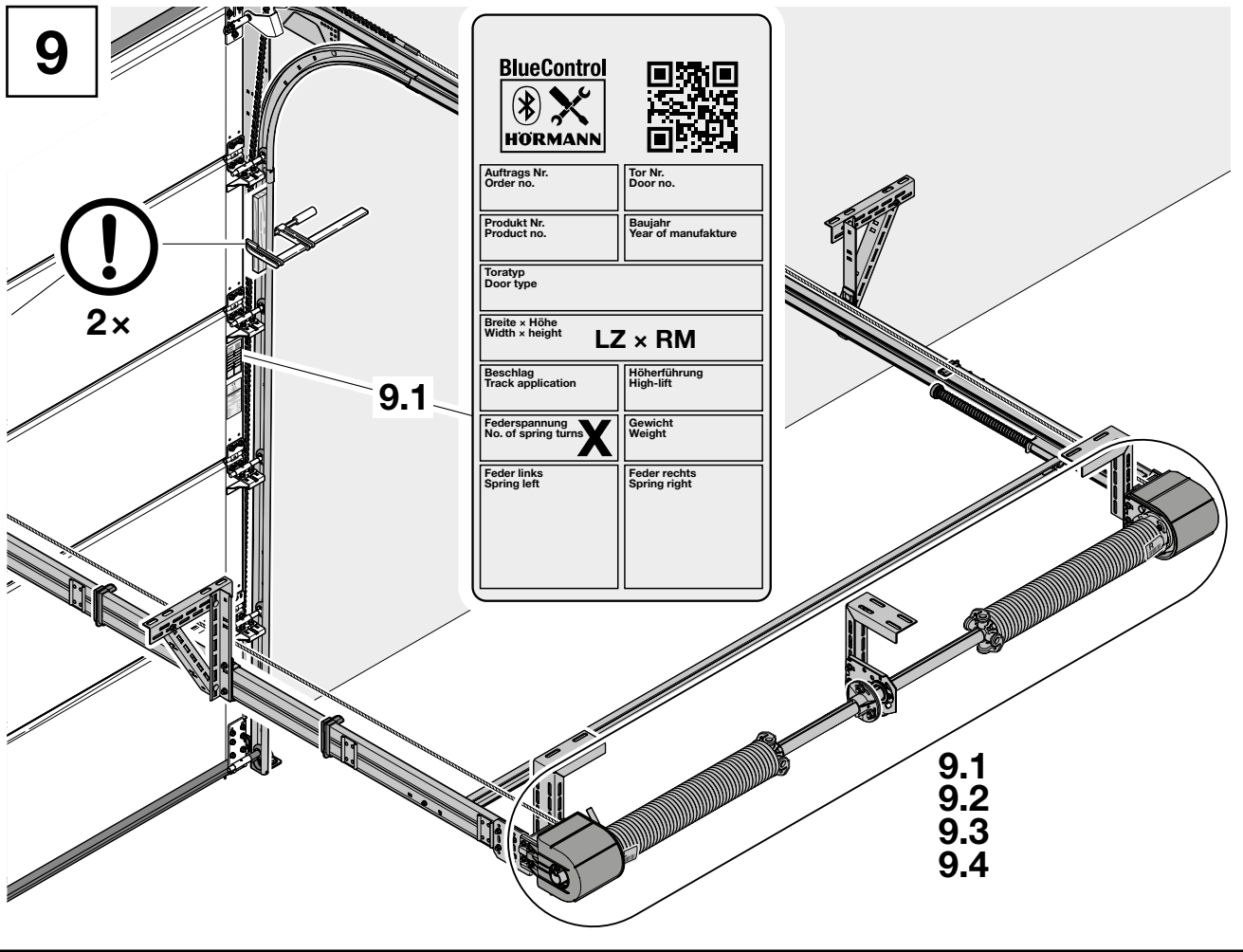

Auftrags Nr. Order no.	Tor Nr. Door no.
Produkt Nr. Product no.	Baujahr Year of manufacture
Toratyp Door type	
Breite x Höhe Width x height LZ x RM	
Beschlag Track application	Höherführung High-lift
Federspannung No. of spring turns X	Gewicht Weight
Feder links Spring left	Feder rechts Spring right

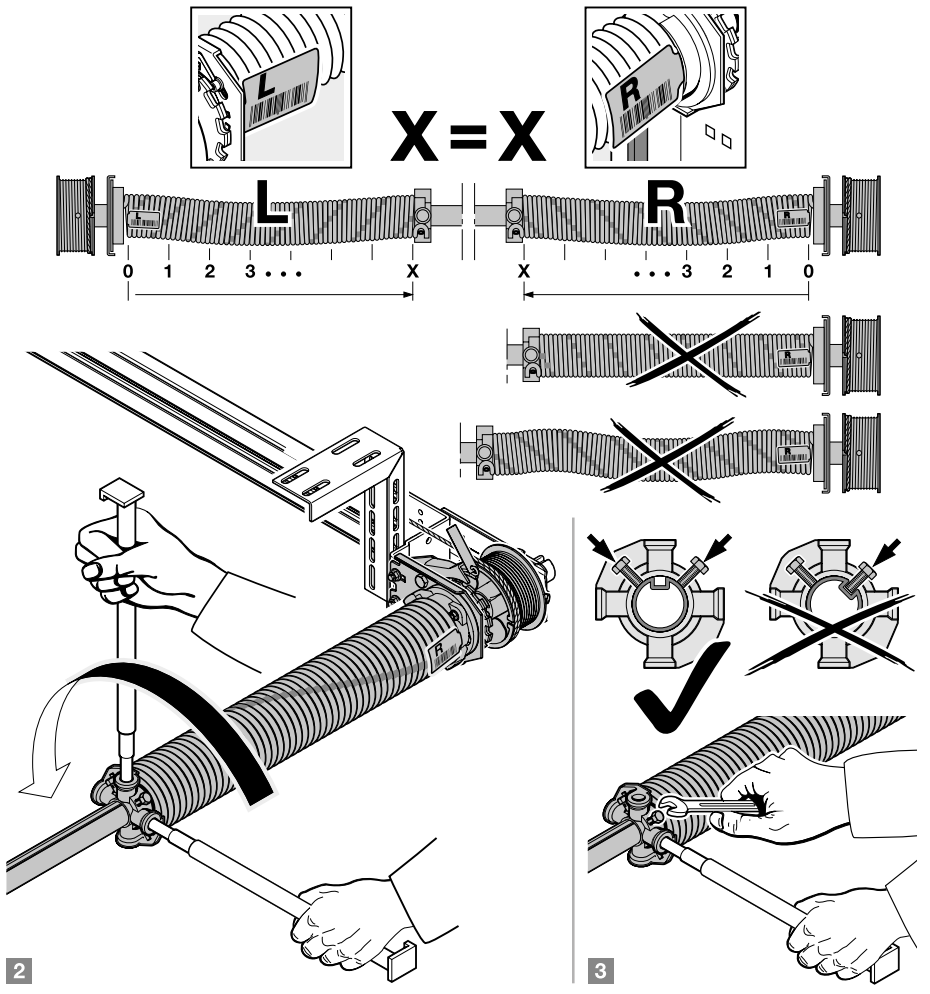
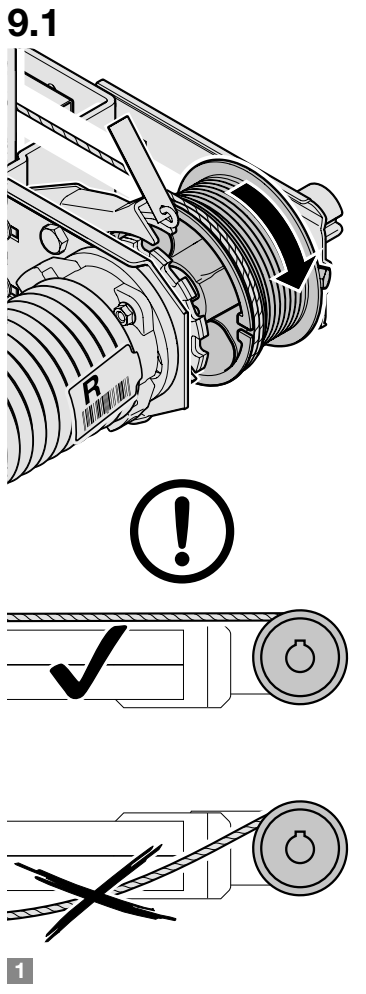

9.2

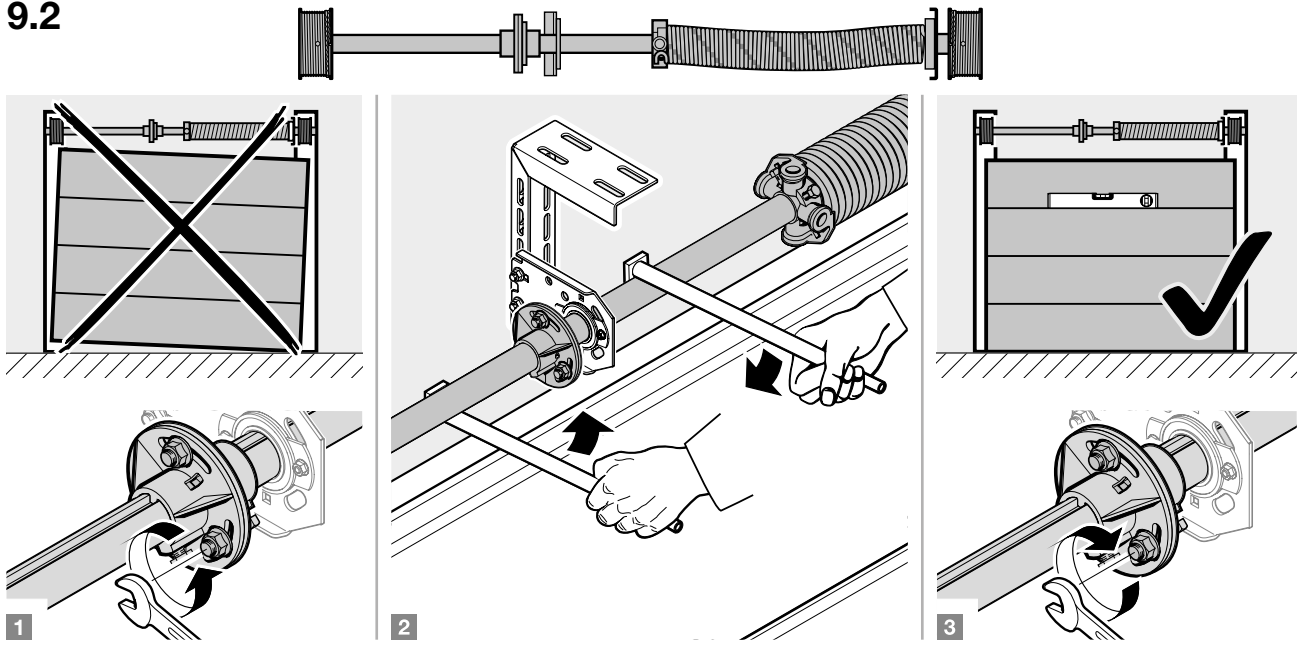

9.3

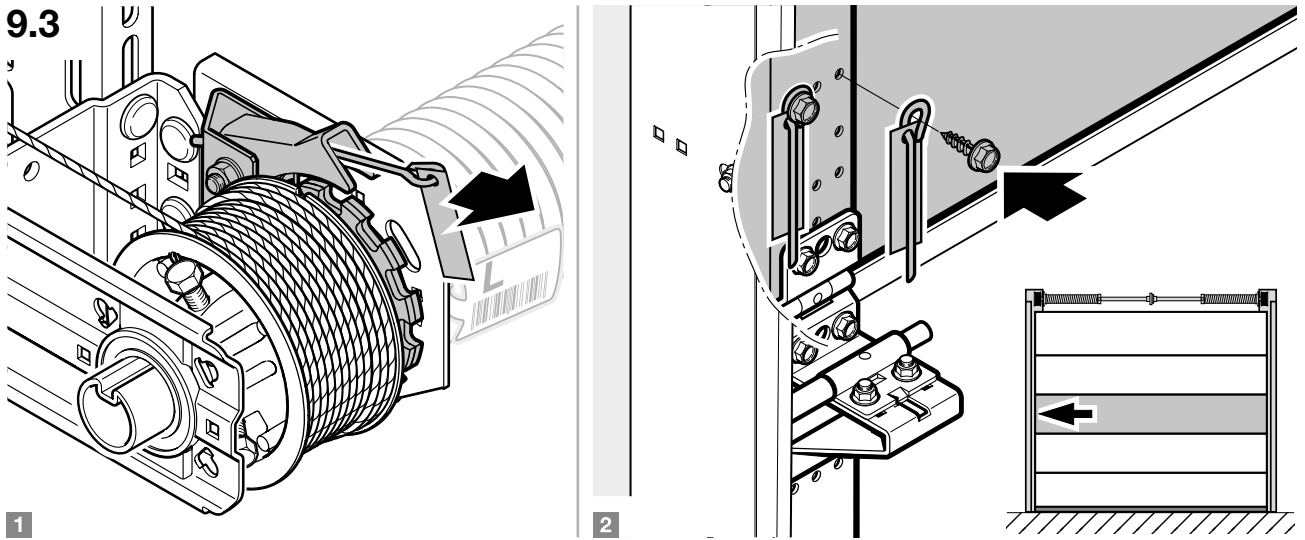

9.4a

RM ≤ 2500



L1

1

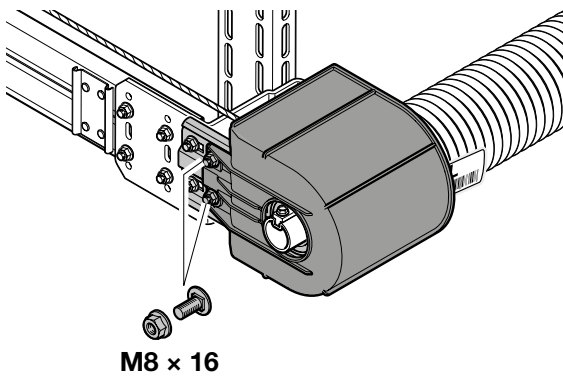
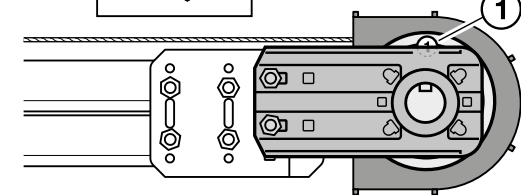

9.4b

RM ≤ 2500



L2

2

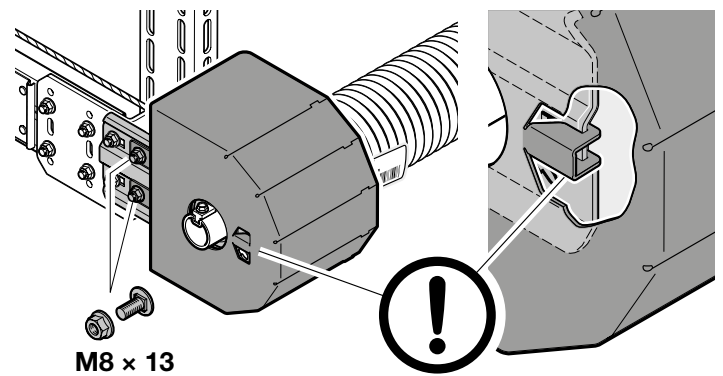
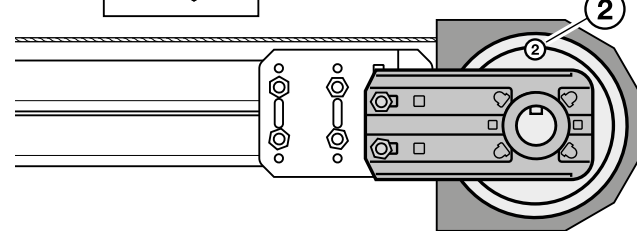

10

10.1

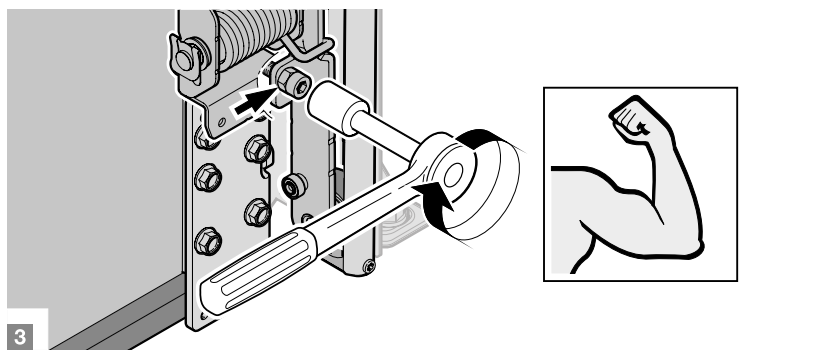
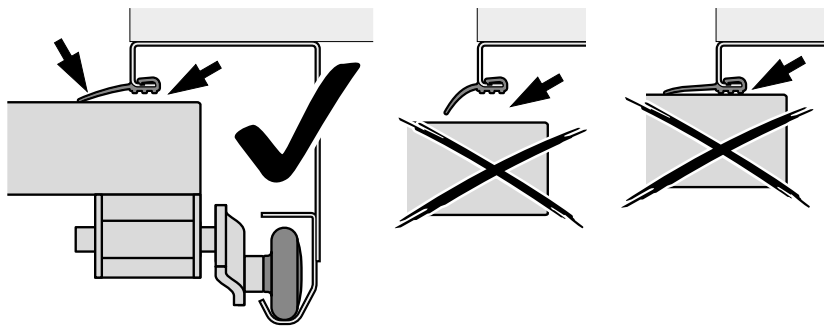
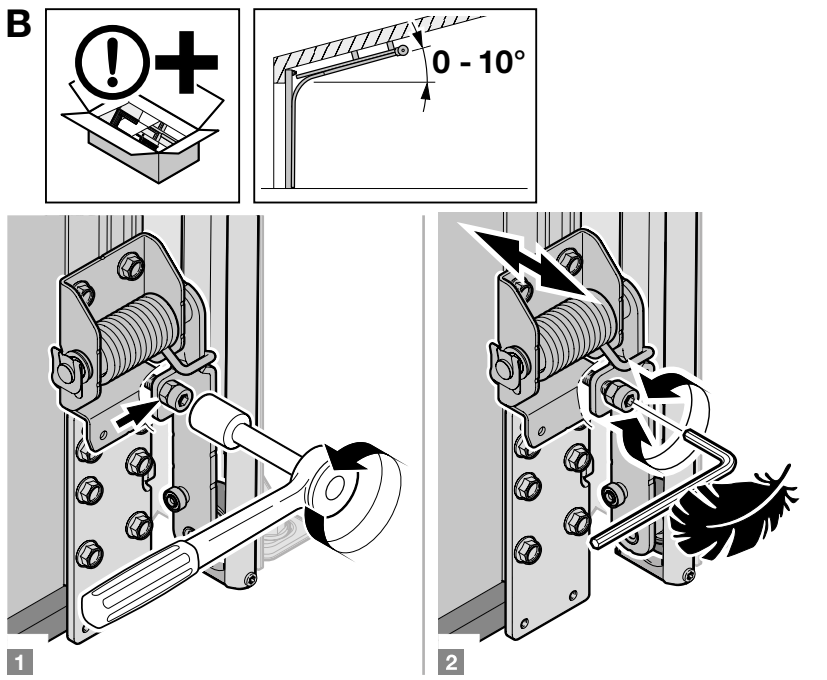
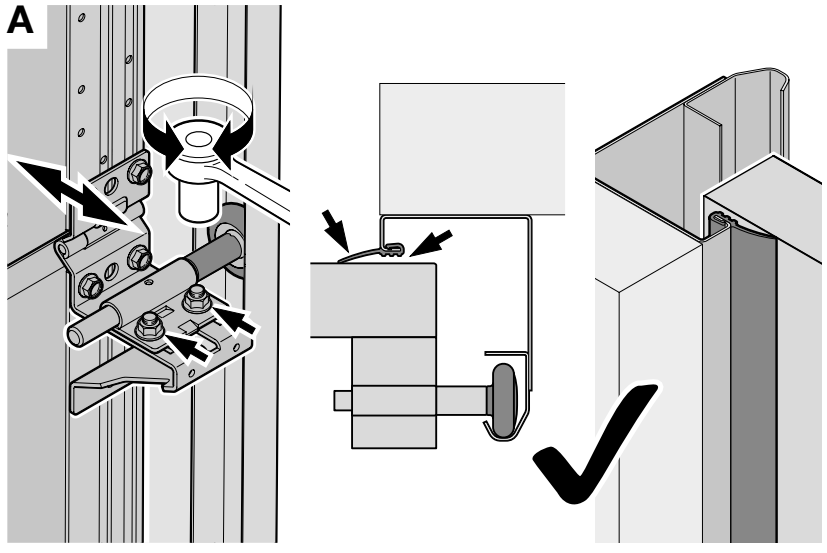
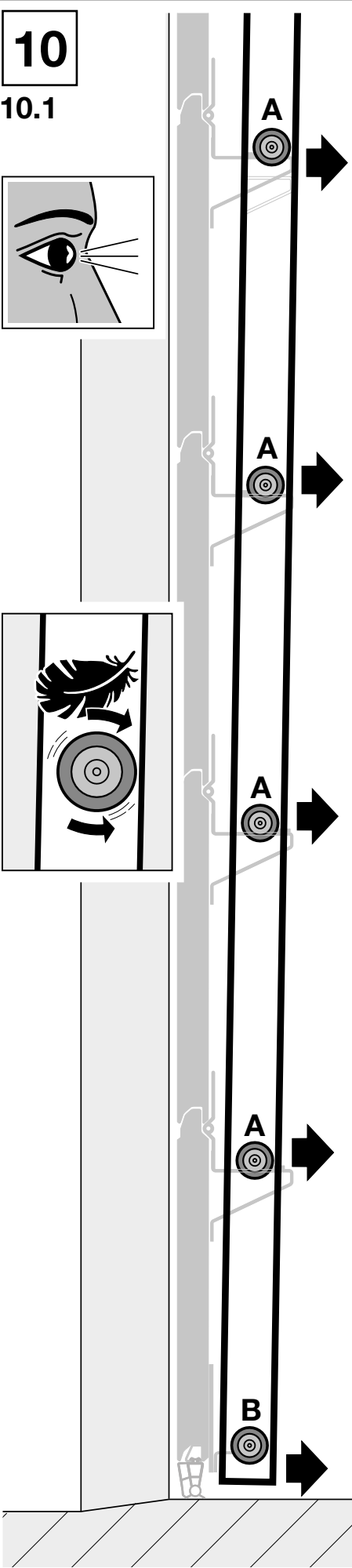
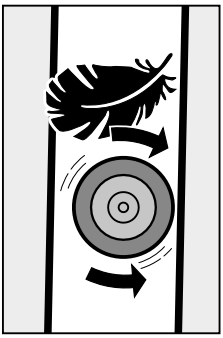
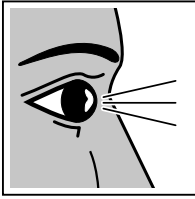

10.2

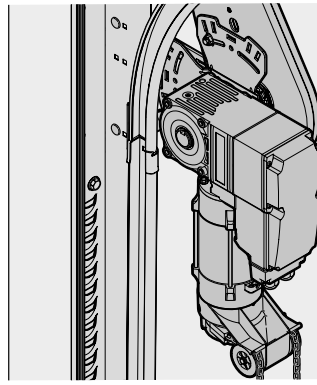
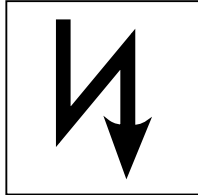
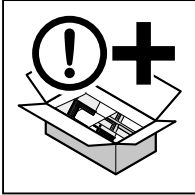

10.3

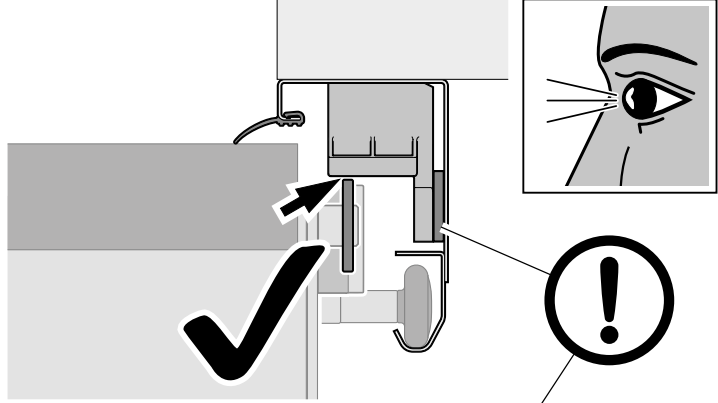
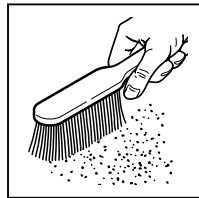
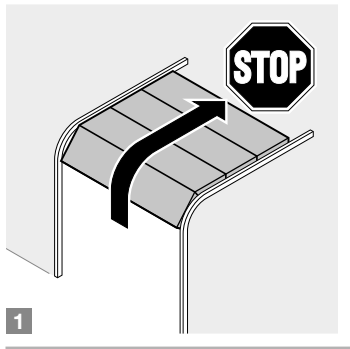
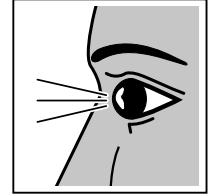
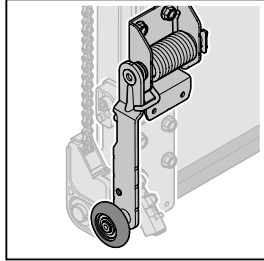
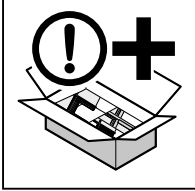

1

M8 x 25

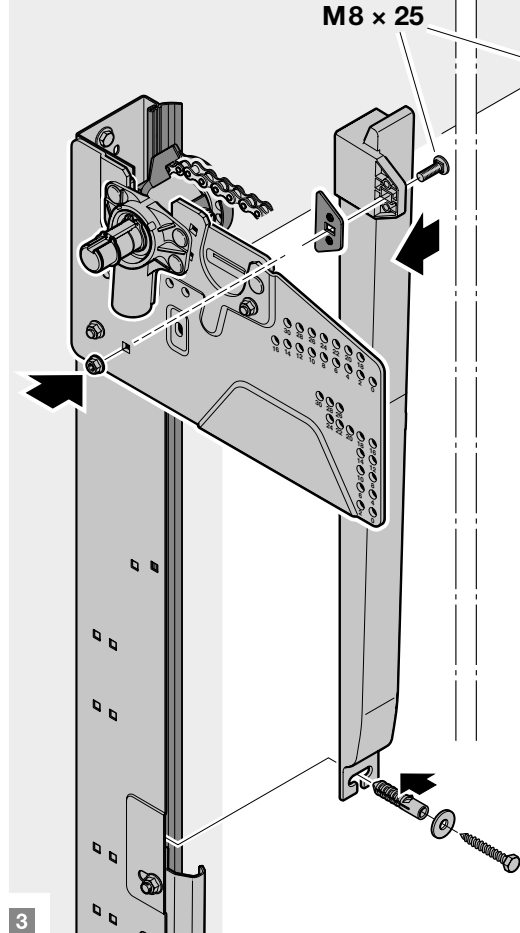
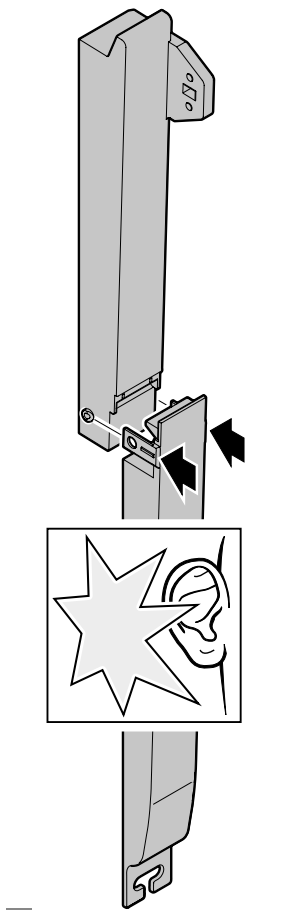

2

3

